

Request For Quotation

Order the parts you need from our real-time inventory database. Simply complete a request for quotation form with your part information and a sales representative will respond to you with price and availability.

[Request For Quotation](#)

Your free datasheet starts on the next page.

More datasheets and data books are available from our homepage: <http://www.datasheetarchive.com>

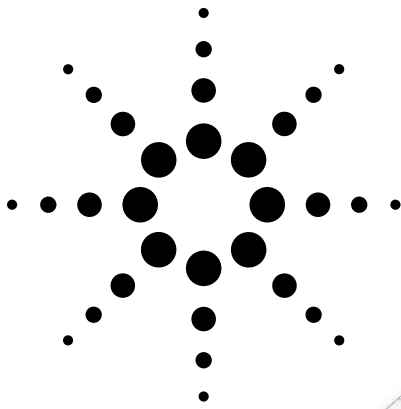

Agilent HSDL-3005 IrDA® Data Compliant Low Power 115.2 kbit/s with Remote Control Infrared Transceiver Data Sheet

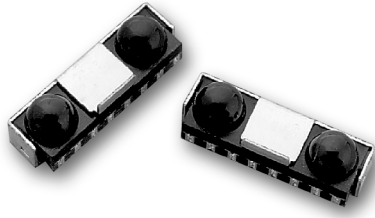

Description

The HSDL-3005 is a small form factor enhanced infrared (IR) transceiver available in Front View and Top View modules. It provides the capability of (1) interface between logic and IR signals for through-air, serial, half-duplex IR data link, and (2) IR remote control transmission for universal remote control applications.

For IR data communication, the HSDL-3005 provides the flexibility of Low Power SIR applications and Remote Control applications with no external components needed for the selection of the type of application. The transceiver is compliant to IrDA® Physical Layer Specifications version 1.4 Low Power from 9.6 kbit/s to 115.2 kbit/s (SIR) and it is IEC 825-Class 1 Eye Safe.

IrDA® Data Features

- Fully compliant to IrDA® physical layer specification 1.4 low power from 9.6 kbit/s to 115.2 kbit/s (SIR)
 - Excellent nose-to-nose operation
 - Link distance up to 50 cm
- Complete shutdown for TxD_IrDA, RxD_IrDA, and PIN diode
- Low power consumption
 - Low idle current, <100 μ A typically
 - Low shutdown current, 10 nA typically
- LED stuck-high protection

Applications

- Mobile data communication and universal remote control transmission
 - Personal digital assistants (PDAs)
 - Mobile phones

Features

- Available in both the front view and top view options
- Guaranteed temperature performance, –25 to 85°C
 - Critical parameters are guaranteed over temperature & supply voltage
- Low power consumption
- Small module size:

	Front View	Top View
– Height:	2.50 mm	2.80 mm
– Width:	8.00 mm	7.50 mm
– Depth:	3.00 mm	3.35 mm
- Minimum external components
 - Integrated single-biased LED resistor
 - Direct interoperability to MPU
 - Programmable TxD features
 - Integrated remote control FET
- V_{CC} supply 2.4 to 3.6 volts
- Integrated EMI shield
- Designed to accommodate light loss with cosmetic windows
- IEC 825-Class I eye safe
- Lead-free package

Remote Control Features

- Wide angle and high radiant intensity
- Spectrally suited to remote control transmission function
- Typical link distance up to 7 meters

CAUTION: The BiCMOS inherent to the design of this component increases the component's susceptibility to damage from electrostatic discharge (ESD). It is advised that normal static precautions be taken in handling and assembly of this component to prevent damage and/or degradation which may be induced by ESD.



The HSDL-3005 has very low idle current and can be shutdown completely to achieve very low power consumption. In the shutdown mode, the PIN diode will be inactive and thus producing very little photo-current even under very bright

ambient light. Such features are ideal for battery operated handheld products such as PDAs and mobile phones.

Application Support Information

The Application Engineering Group is available to assist you

with the application design associated with HSDL-3005 infrared transceiver module. You can contact them through your local sales representatives for additional details.

Order Information

Part Number	Packaging Type	Package	Quantity
HSDL-3005-021	Tape and Reel	Front View	2500
HSDL-3005-028	Tape and Reel	Top View	2500

Marking Information

The unit is marked with “M” and the datecode “YWW” on the shield for Front option. For Top option, the part is marked as

“YWW” where Y is the last digit of the year, and WW is the work week.

- M = Mira
- yy = year
- ww = work week

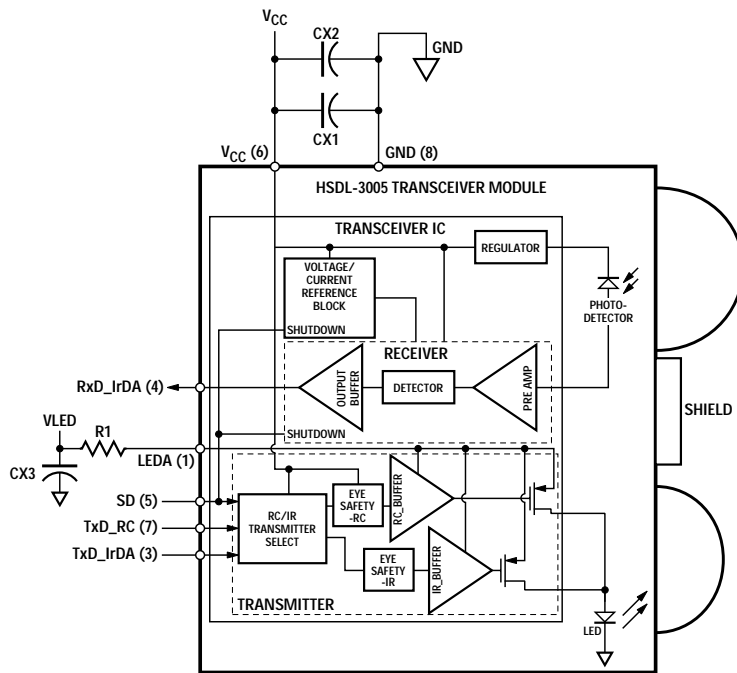

Figure 1. Functional block diagram.

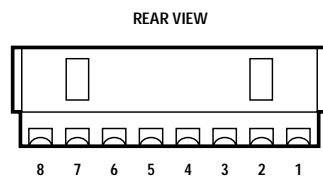

Figure 2. Pinout.

I/O Pins Configuration Table

Pin	Symbol	I/O	Description	Notes
1	LEDA	I	IR and Remote Control LED Anode	1
2	N.C.	–	No Connection	2
3	TxD_IrDA	I	IrDA Transmitter Data Input. Active High	3
4	RxD_IrDA	O	IrDA Receiver Data Output. Active Low	4
5	SD	I	Shutdown. Active High	5
6	V _{CC}	I	Supply Voltage	6
7	TxD_RC	I	Remote Control Transmission Input. Active High	7
8	GND	I	Connect to System Ground	8
–	Shield	–	EMI Shield	9

Notes:

1. Tied through external resistor, R1, to VLED from 2.4 to 4.5 Volts.
2. No Connection.
3. Logic high turns on the IrDA LED. If held HIGH longer than ~50 μ s, the IrDA LED is turned off. TxD_IrDA must be driven either HIGH or LOW. Do not leave the pin floating.
4. Output is at LOW pulse response when light pulse is seen.
5. Complete shutdown TxD_IrDA, RxD_IrDA, and PIN diode.
6. Regulated, 2.4 to 3.6 Volts.
7. Logic high turns on the RC LED. If held HIGH longer than ~50 μ s, the RC LED is turned off. TxD_RC must be driven either HIGH or LOW. Do not leave the pin floating.
8. Tie this pin to system ground.
9. Tie to system ground via a low inductance trace. For best performance, do not tie it to the HSDL-3005 GND pin directly.

Recommended Application Circuit Components

Component	Recommended Value
R1	2.7 $\Omega \pm 5\%$, 0.25 Watt @ Vled = 2.4 V 3.3 $\Omega \pm 5\%$, 0.25 Watt @ Vled = 2.7 V 4.7 $\Omega \pm 5\%$, 0.25 Watt @ Vled = 3.0 V 5.6 $\Omega \pm 5\%$, 0.25 Watt for 3.0 < Vled < 3.6 V 6.8 $\Omega \pm 5\%$, 0.25 Watt @ Vled = 3.6 V 10.0 $\Omega \pm 5\%$, 0.25 Watt for 3.6 \leq Vled \leq 4.5 V
CX1 ^[1]	0.47 μ F $\pm 20\%$, X7R Ceramic
CX2 ^[1] , CX3	6.8 μ F $\pm 20\%$, Tantalum

Note:

1. CX1 and CX2 must be placed within 0.7 cm of HSDL-3005 to obtain optimum noise immunity.

Different Remote Control Configuration for HSDL-3005

The HSDL-3005 can operate in the single-TxD programmable mode or the two-TxD direct transmission mode.

(A) Single-TxD Programmable Mode

In the single-TxD programmable mode, only one input pin (TxD_IrDA input pin) is used.

The transceiver is in default mode (IrDA) when powered up. User needs to apply the following programming sequence to both the TxD_IrDA and SD inputs to enable the transceiver to operate in either the IrDA or remote control mode.

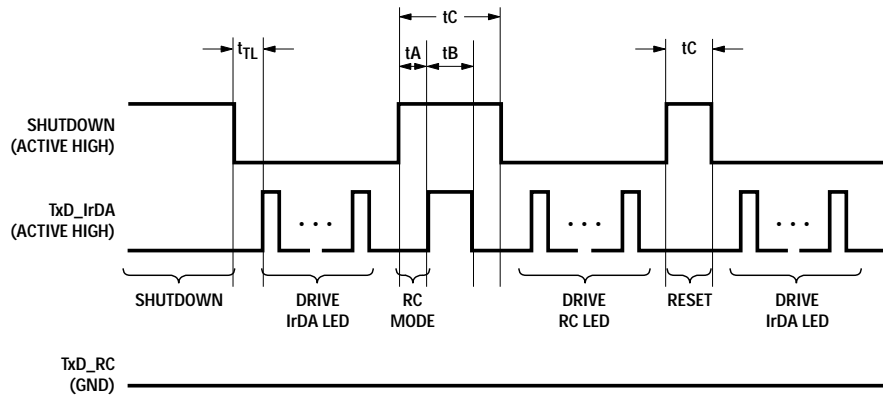

(B) Single-TxD Programmable Mode

SD	TXD_IrDA	TXD_RC	LED	Remarks
0	0	0	OFF	IR Rx enabled. Idle mode
0	0	1	ON	Remote control operation
0	1	0	ON	IrDA Tx operation
0	1	1	ON	Not recommended
1	0	0	OFF	Shutdown mode*

* The shutdown condition will set the transceiver to the default mode (IrDA).

Absolute Maximum Ratings at $T_A = 25^\circ\text{C}$

For implementations where case to ambient thermal resistance is $\leq 50^\circ\text{C}/\text{W}$.

Parameter	Symbol	Min.	Max.	Units	Conditions
Storage Temperature	T_S	-40	100	$^\circ\text{C}$	
Operating Temperature	T_A	-25	85	$^\circ\text{C}$	
LED Supply Voltage	V_{LED}	0	6	V	
Supply Voltage	V_{CC}	0	6	V	
Output Voltage: RxD	V_O	0	6	V	
LED Current Pulse Amplitude	I_{VLED}		300	mA	$\leq 90 \mu\text{s}$ Pulse Width $\leq 20\%$ Duty Cycle

Recommended Operating Conditions

Parameter	Symbol	Min.	Max.	Units	Conditions
Operating Temperature	T_A	-25	85	$^\circ\text{C}$	
Supply Voltage	V_{CC}	2.4	3.6	V	
LED Supply Voltage	V_{LED}	2.4	4.5	V	
Logic Input Voltage for TxD_IrDA, TxD_RC	Logic High	V_{IH}	$2/3 V_{CC}$	V_{CC}	V
	Logic Low	V_{IL}	0	$1/3 V_{CC}$	V
Receiver Input Irradiance	Logic High	E_{IH}	0.0081	500	mW/cm^2 For in-band signals $\leq 115.2 \text{ kbit/s}$ ^[3]
	Logic Low	E_{IL}		0.3	$\mu\text{W}/\text{cm}^2$ For in-band signals ^[3]
Receiver Data Rate		9.6	115..2	kbit/s	

Note:

3. An in-band optical signal is a pulse/sequence where the peak wavelength, λ_p , is defined as $850 \leq \lambda_p \leq 900 \text{ nm}$, and the pulse characteristics are compliant with the IrDA Serial Infrared Physical Layer Link Specification v1.4.

Electrical and Optical Specifications

Specifications (Min. & Max. values) hold over the recommended operating conditions unless otherwise noted. Unspecified test conditions may be anywhere in their operating range. All typical values (Typ.) are at 25°C, V_{CC} set to 3.0 V.

Parameter	Symbol	Min.	Typ.	Max.	Units	Conditions
Receiver						
Viewing Angle	$2\theta_{1/2}$	30			°	
Peak Sensitivity Wavelength	λ_P		875		nm	
RxD_IrDA Output Voltage	Logic High Logic Low	V _{OH} V _{OL}	V _{CC} - 0.2 0	V _{CC} 0.4	V V	I _{OH} = -200 µA, EI ≤ 0.3 µW/cm ²
RxD_IrDA Pulse Width (SIR) ^[4]	t _{RPW}	1	2.3	7.5	µs	$\theta_{1/2} \leq 15^\circ$, C _L = 9 pF
RxD_IrDA Rise & Fall Times	t _r , t _f		30	100	ns	C _L = 9 pF
Receiver Latency Time ^[5]	t _L		25	50	µs	EI = 9.0 µW/cm ²
Receiver Wake Up Time ^[6]	t _{RW}		75	200	µs	EI = 10 mW/cm ²
Infrared (IR) Transmitter						
IR Radiant Intensity	I _{EH}	4	20	35	mW/sr	$\theta_{1/2} \leq 15^\circ$, TxD_IrDA ≥ V _{IH} , T _A = 25 °C
IR Viewing Angle	$2\theta_{1/2}$	30		60	°	
IR Peak Wavelength	λ_P		885		nm	
TxD_IrDA Logic Levels	High Low	V _{IH} V _{IL}	2/3 V _{CC} 0	V _{CC} 1/3 V _{CC}	V V	
TxD_IrDA Input Current	High Low	I _H I _L	0.02 -0.02	1 1	µA µA	V _I ≥ V _{IH} 0 ≤ V _I ≤ V _{IL}
LED Current	Shutdown	I _{VLED}	0.02	1	µA	V _I (SD) ≥ V _{IH} ,
Wake Up Time ^[7]	t _{TW}		180	500	ns	
Optical Pulse Width (SIR)	t _{PW(SIR)}	1.41		1.6	µs	t _{PW(TXD)} = 1.6 µs at 115.2 kbit/s
Maximum Optical Pulse Width ^[8]	t _{PW(Max)}		25	120	µs	
Data Setup Time	t _A	25			ns	
Data Pulsewidth	t _B	25			ns	
Programming Time	t _C	25			ns	
TxD Rise & Fall Times (Optical)	t _r , t _f			600	ns	
LED Anode On-State Voltage	V _{ON (LEDA)}		2.6		V	I _{LEDA} = 100 mA, V _I (TxD) ≥ V _{IH}
Remote Control (RC) Transmitter						
RC Radiant Intensity	I _{EH}		65		mW/sr	$\theta_{1/2} \leq 15^\circ$, TxD_RC ≥ V _{IH} , T _A = 25°C
RC Viewing Angle	$2\theta_{1/2}$	30		60	°	
RC Peak Wavelength	λ_P		885		nm	
TxD_RC Logic Levels	High Low	V _{IH} V _{IL}	2/3 V _{CC} 0	V _{CC} 1/3 V _{CC}	V V	
TxD_RC Input Current	High Low	I _H I _L	0.02 -0.02	1 1	µA µA	V _I ≥ V _{IH} 0 ≤ V _I ≤ V _{IL}
LED Anode On-State Voltage	V _{ON (LEDA)}		2.1		V	I _{LEDA} = 200 mA, V _I (TxD) ≥ V _{IH}

Electrical and Optical Specifications (Cont'd.)

Parameter		Symbol	Min.	Typ.	Max.	Units	Conditions
Transceiver							
Input Current	High	I_H		0.01	1	μA	$V_I \geq V_{IH}$
	Low	I_L	-1	-0.02	1	μA	$0 \leq V_I \leq V_{IL}$
Supply Current	Shutdown	I_{CC1}		0.01	1	μA	$V_{SD} \geq V_{CC} - 0.5, T_A = 25^\circ\text{C}$
	Idle (Standby)	I_{CC2}		50	100	μA	$V_{I(TXD)} \leq V_{IL}, EI = 0$
	Active	I_{CC3}		300		μA	$V_{I(TXD)} \geq V_{IL}, EI = 10 \text{ mW/cm}^2$

Notes:

- An in-band optical signal is a pulse/sequence where the peak wavelength, λ_p , is defined as $850 \text{ nm} \leq \lambda_p \leq 900 \text{ nm}$, and the pulse characteristics are compliant with the IrDA Serial Infrared Physical Layer Link Specification version 1.4.
- For in-band signals 9.6 kbit/s to 115.2 kbit/s where $9 \mu\text{W/cm}^2 \leq EI \leq 500 \text{ mW/cm}^2$.
- Latency is defined as the time from the last TxD_IrDA light output pulse until the receiver has recovered full sensitivity.
- Receiver Wake Up Time is measured from V_{CC} power ON to valid RxD_IrDA output.
- Transmitter Wake Up Time is measured from V_{CC} power ON to valid light output in response to a TxD_IrDA pulse.
- The Optical PW is defined as the maximum time which the IR LED will turn on; this is to prevent the long Turn On time for the IR LED.

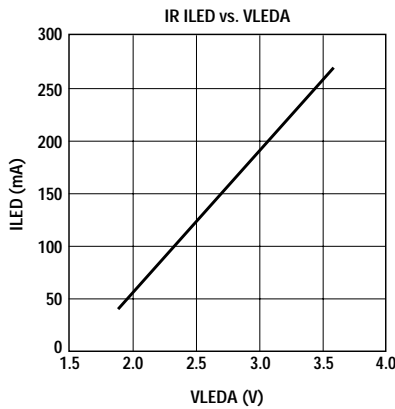

Figure 3. VLEDA vs. ILEDA at room temperature for IR mode.

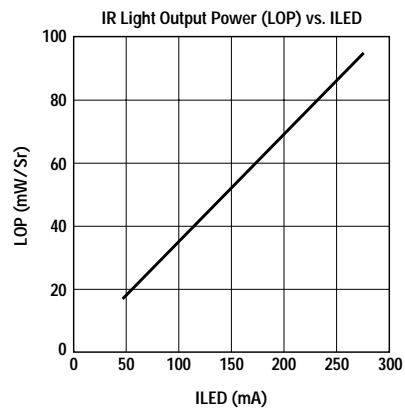

Figure 4. ILEDA vs. LED radiant intensity at room temperature for IR mode.

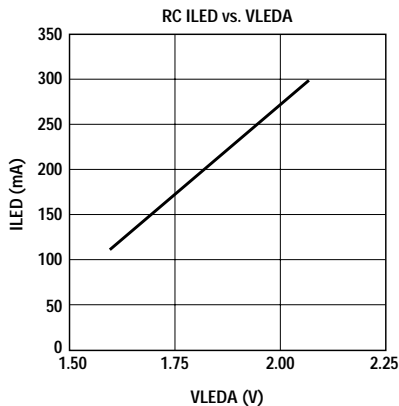

Figure 5. VLEDA vs. ILEDA at room temperature for RC mode.

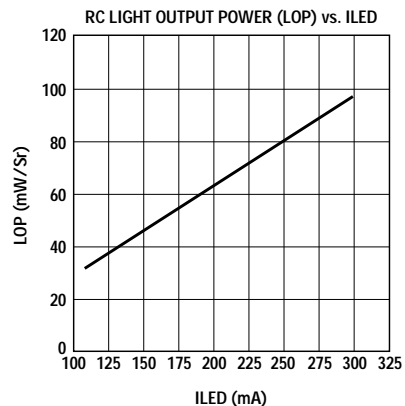
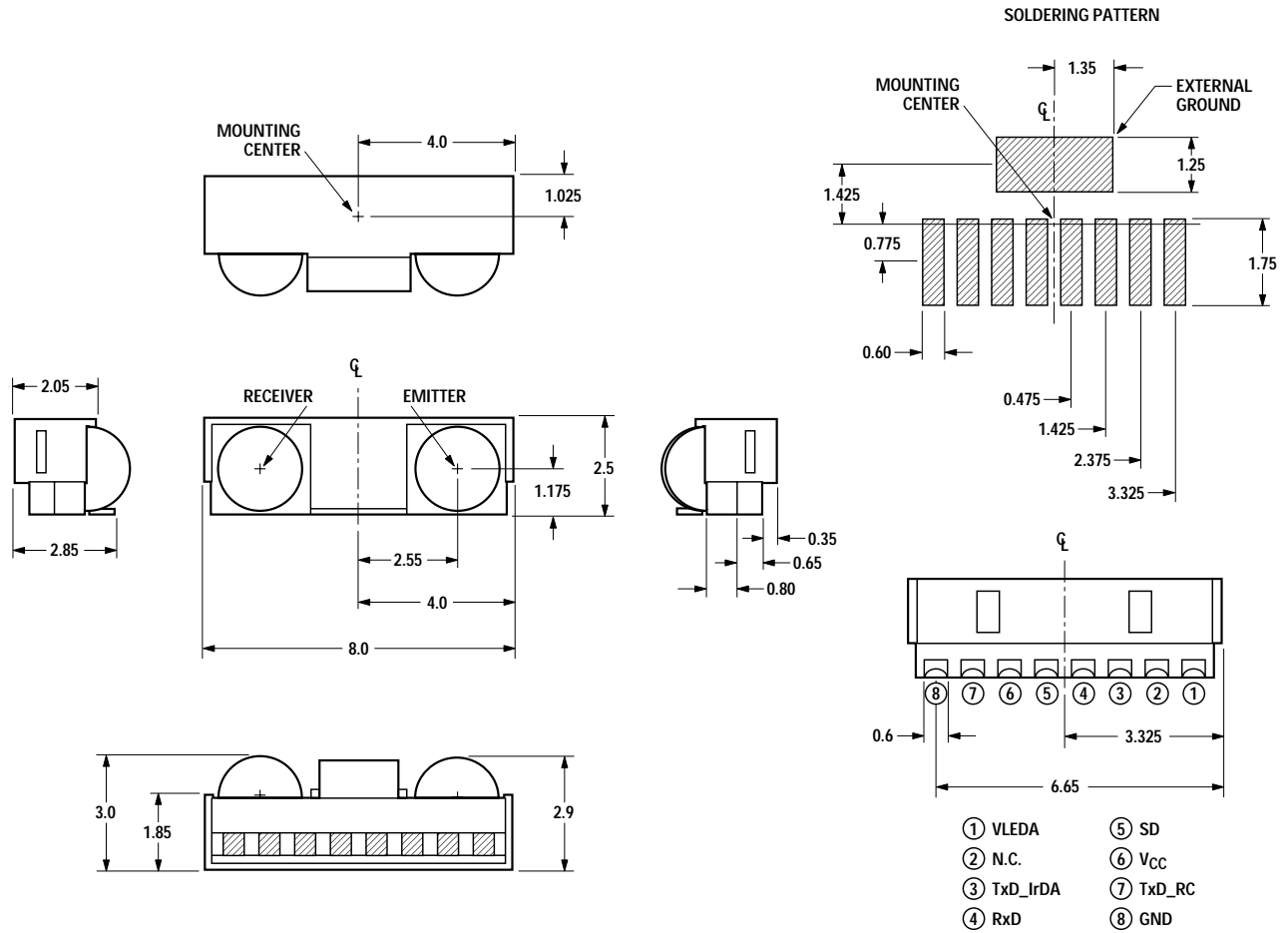

Figure 6. ILEDA vs. LED radiant intensity at room temperature for RC mode.

HSDL-3005-021 (Front) Package Dimensions



- NOTES:
1. ALL DIMENSIONS IN MILLIMETERS (mm).
 2. DIMENSION TOLERANCE IS 0.2 mm UNLESS OTHERWISE SPECIFIED.
 3. COPLANAIITY: 0.05 TO -0.150 mm.

HSDL-3005-021(Front) Tape and Reel Dimensions

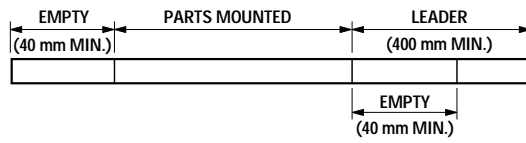
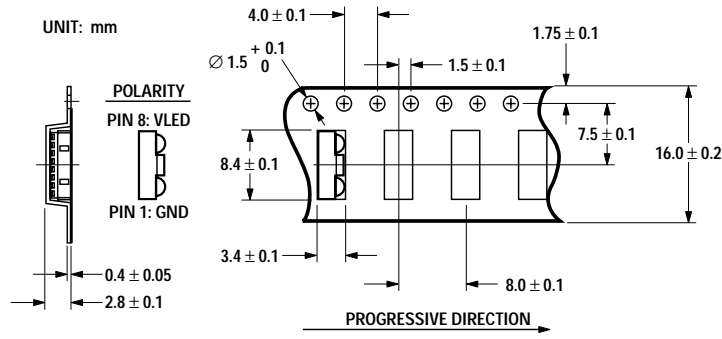

OPTION #	"B"	"C"	QUANTITY
001	178	60	500
021	330	80	2500

UNIT: mm

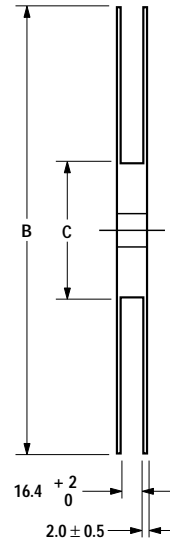
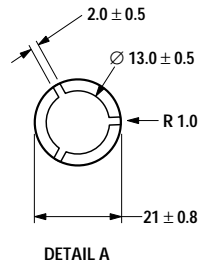
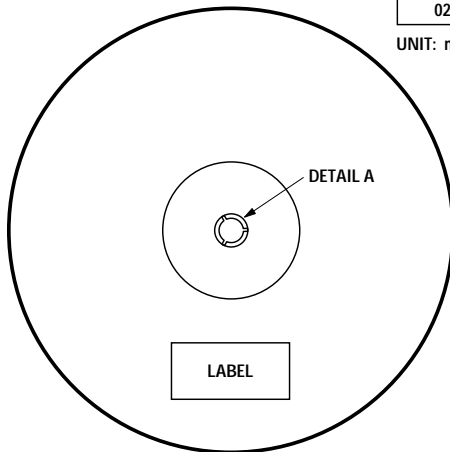

HSDL-3005-028 (Top) Package Dimensions

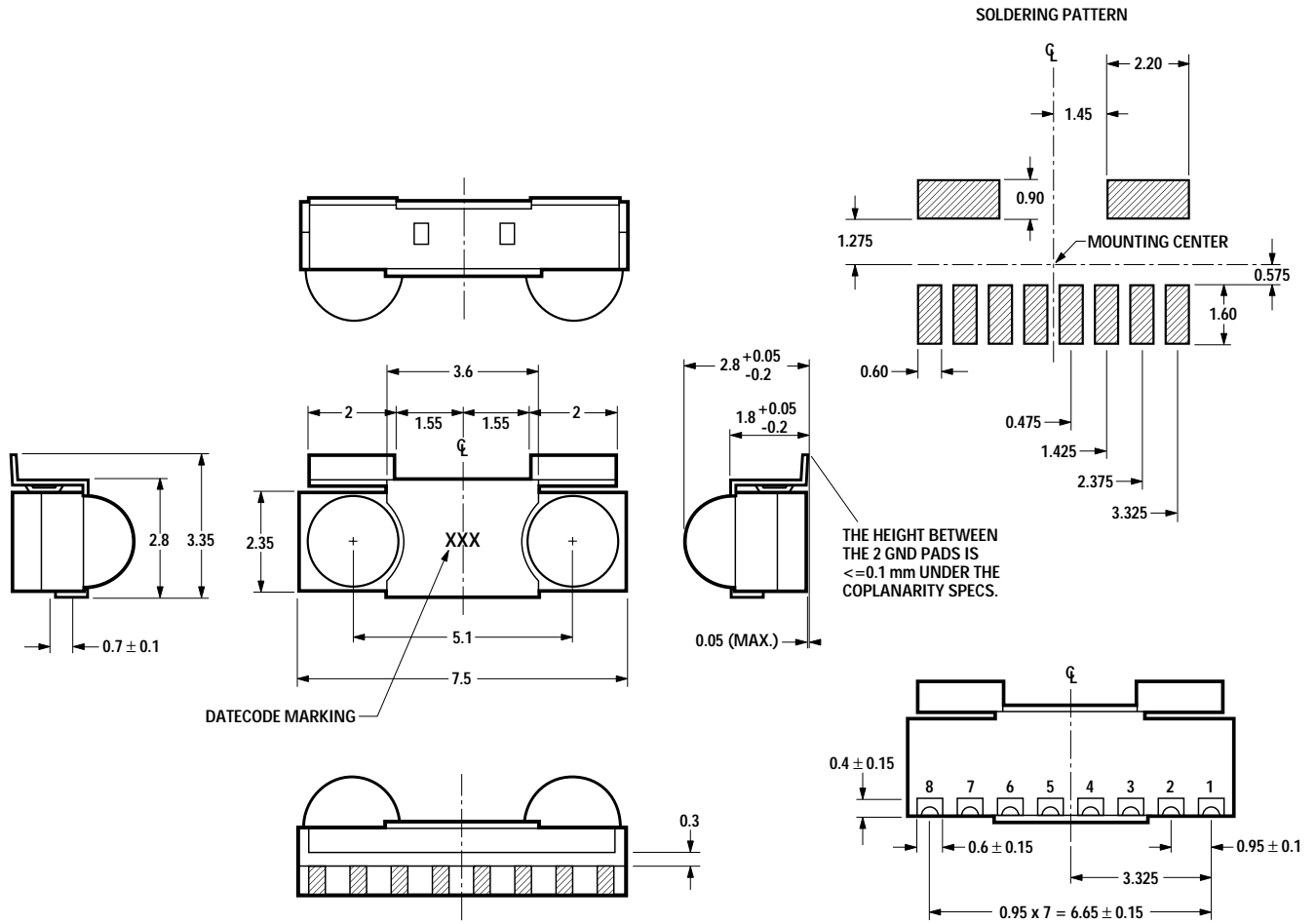

- NOTES:
 1. ALL DIMENSIONS IN MILLIMETERS (mm).
 2. DIMENSION TOLERANCE IS 0.2 mm UNLESS OTHERWISE SPECIFIED.

- | | |
|------------|----------|
| 1 VLED | 5 SD |
| 2 N.C. | 6 VCC |
| 3 TxD_IrDA | 7 TxD_RC |
| 4 RxD | 8 GND |

HSDL-3005-028 (Top) Tape and Reel Dimensions

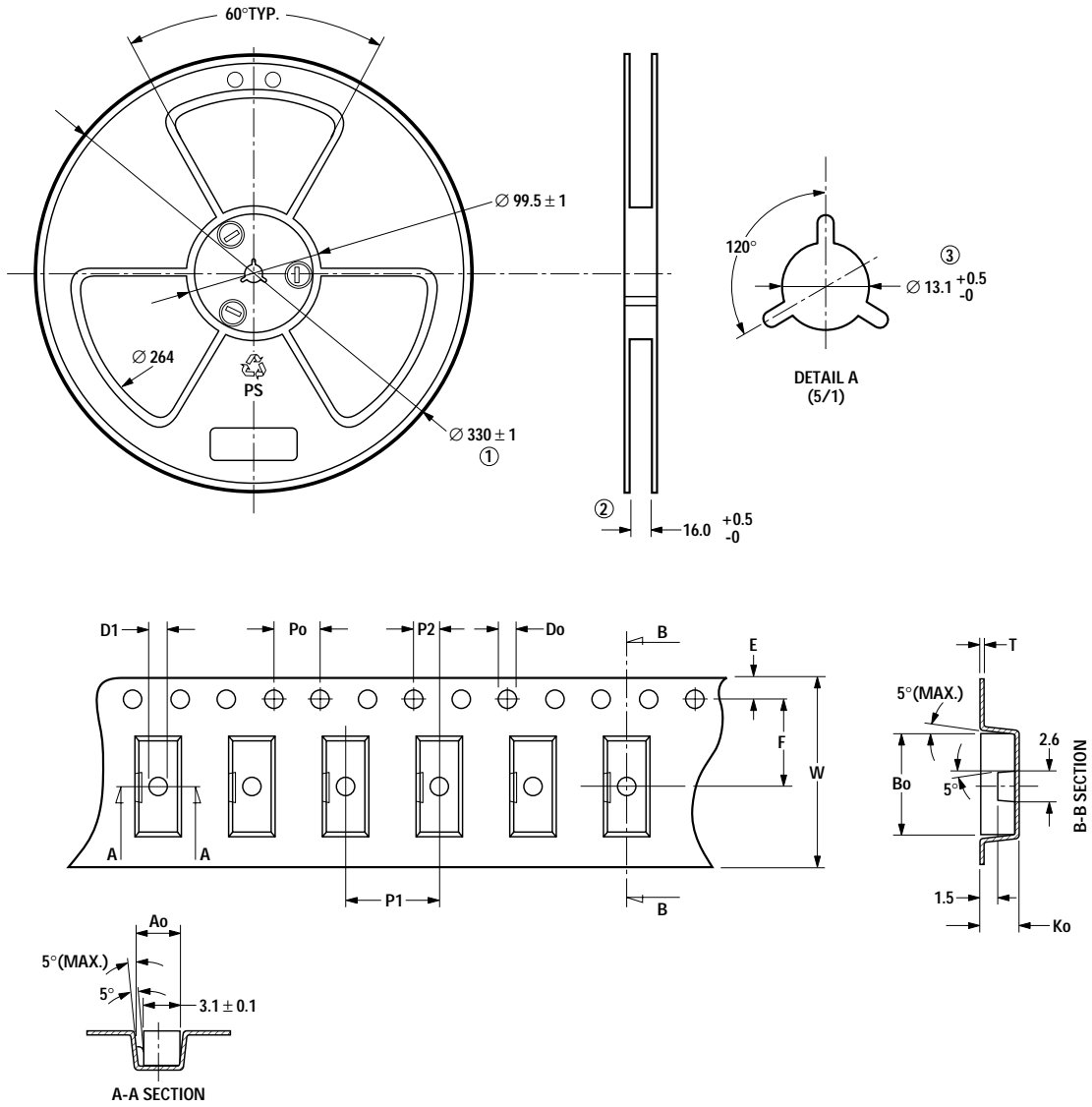

UNIT: mm

SYMBOL	Ao	Bo	Ko	Po	P1	P2	T
SPEC	3.65 ± 0.10	7.90 ± 0.10	2.75 ^{+0.05} / _{-0.10}	4.00 ± 0.10	8.00 ± 0.10	2.00 ± 0.10	0.40 ± 0.10
SYMBOL	E	F	Do	D1	W	10Po	
SPEC	1.75 ± 0.10	7.50 ± 0.10	1.55 ± 0.05	1.50 (MIN.)	16.00 ± 0.30	40.00 ± 0.20	

NOTES:

1. 10 SPROCKET HOLE PITCH CUMULATIVE TOLERANCE IS ± 0.2 mm.
2. CARRIER CAMBER SHALL NOT BE MORE THAN 1 mm PER 100 mm THROUGH A LENGTH OF 250 mm.
3. Ao AND Bo MEASURED ON A PLACE 0.3 mm ABOVE THE BOTTOM OF THE PACKET.
4. Ko MEASURED FROM A PLACE ON THE INSIDE BOTTOM OF THE POCKET TO TOP SURFACE OF CARRIER.
5. POCKET POSITION RELATIVE TO SPROCKET HOLE MEASURED AS TRUE POSITION OF POCKET, NOT POCKET HOLE.

HSDL-3005 Moisture Proof Packaging

All HSDL-3005 options are shipped in moisture proof package. Once opened, moisture absorption begins.

This part is compliant to JEDEC Level 4.

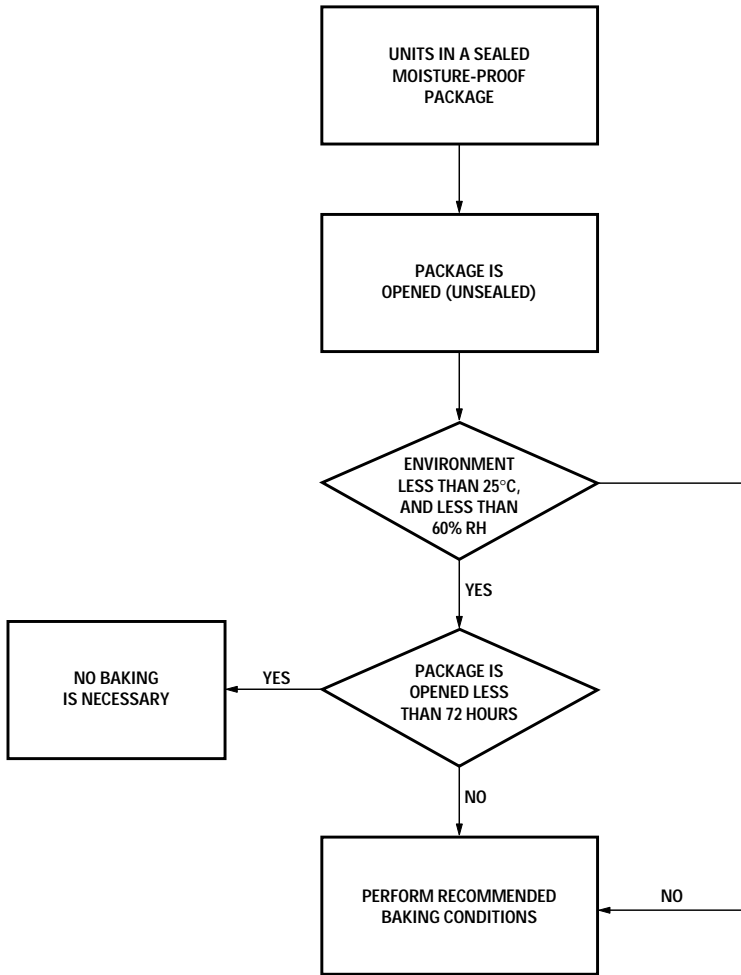

Figure 7. Baking conditions chart.

Baking Conditions

If the parts are not stored in dry conditions, they must be baked before reflow to prevent damage to the parts.

Package	Temp.	Time
In reels	60°C	≥ 48 hours
In bulk	100°C	≥ 4 hours
	125°C	≥ 2 hours
	150°C	≥ 1 hour

Baking should only be done once.

Recommended Storage Conditions

Storage Temperature	10°C to 30°C
Relative Humidity	below 60% RH

Time from Unsealing to Soldering

After removal from the bag, the parts should be soldered within three days if stored at the recommended storage conditions. If times longer than three days are needed, the parts must be stored in a dry box.

Recommended Reflow Profile

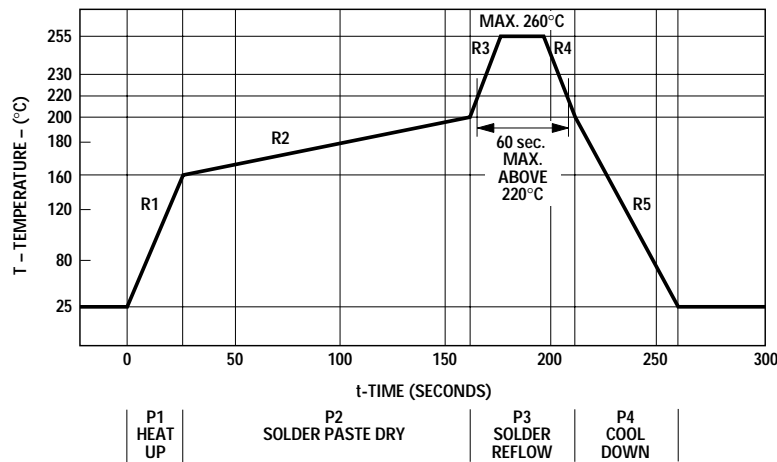

Process Zone	Symbol	ΔT	Maximum ΔT/Δtime
Heat Up	P1, R1	25°C to 160°C	4°C/s
Solder Paste Dry	P2, R2	160°C to 200°C	0.5°C/s
Solder Reflow	P3, R3	200°C to 255°C (260°C at 10 seconds max.)	4°C/s
	P3, R4	255°C to 200°C	-6°C/s
Cool Down	P4, R5	200°C to 25°C	-6°C/s

The reflow profile is a straight-line representation of a nominal temperature profile for a convective reflow solder process. The temperature profile is divided into four process zones, each with different $\Delta T/\Delta \text{time}$ temperature change rates. The $\Delta T/\Delta \text{time}$ rates are detailed in the above table. The temperatures are measured at the component to printed circuit board connections.

In **process zone P1**, the PC board and HSDL-3005 castellations pins are heated to a temperature of 160°C to activate the flux in the solder paste. The temperature ramp up rate, R1, is limited to 4°C per second to allow for even heating of both the PC board and HSDL-3005 castellations.

Process zone P2 should be of sufficient time duration (60 to 120 seconds) to dry the solder paste. The temperature is raised to a level just below the liquidus point of the solder, usually 200°C (392°F).

Process zone P3 is the solder reflow zone. In zone P3, the temperature is quickly raised above the liquidus point of solder to 255°C (491°F) for optimum results. The dwell time above the liquidus point of solder should be between 20 and 60 seconds. It usually takes about 20 seconds to assure proper coalescing of the solder balls into liquid solder and the formation of good solder connections. Beyond a dwell time of 60 seconds, the intermetallic growth within the

solder connections becomes excessive, resulting in the formation of weak and unreliable connections. The temperature is then rapidly reduced to a point below the solidus temperature of the solder, usually 200°C (392°F), to allow the solder within the connections to freeze solid.

Process zone P4 is the cool down after solder freeze. The cool down rate, R5, from the liquidus point of the solder to 25°C (77°F) should not exceed 6°C per second maximum. This limitation is necessary to allow the PC board and HSDL-3005 castellations to change dimensions evenly, putting minimal stresses on the HSDL-3005 transceiver.

Appendix A: SMT Assembly Application Note

1.0 Solder Pad, Mask and Metal Stencil

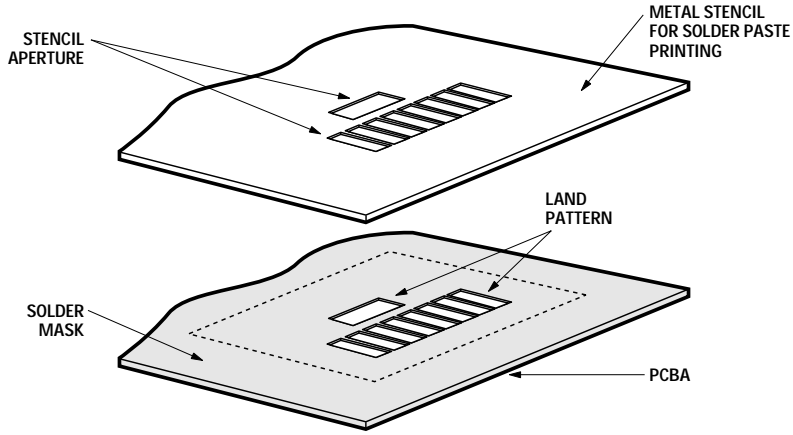

Figure 8. Stencil and PCBA.

1.1 Recommended Land Pattern

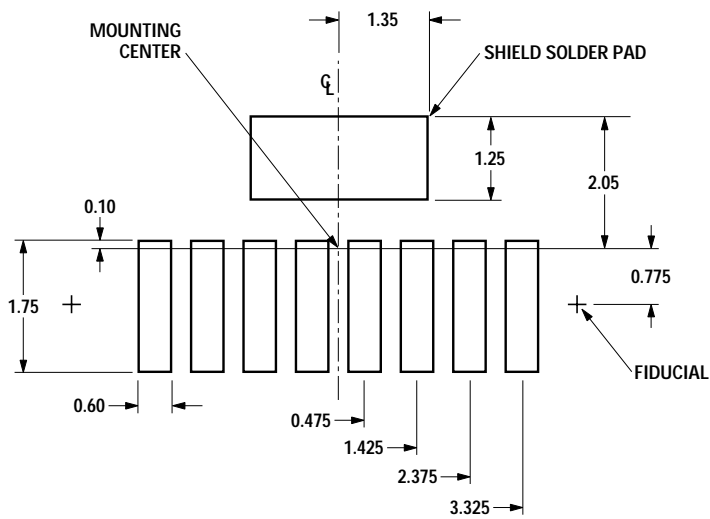

Figure 9. Land pattern.

1.2 Recommended Metal Solder Stencil Aperture

It is recommended that only a 0.152 mm (0.006 inch) or a 0.127 mm (0.005 inch) thick stencil be used for solder paste printing. This is to ensure adequate printed solder paste volume and no shorting. See the table below the drawing for combinations of metal stencil aperture and metal stencil thickness that should be used.

Aperture opening for shield pad is 3.05 mm x 1.1 mm as per land pattern.

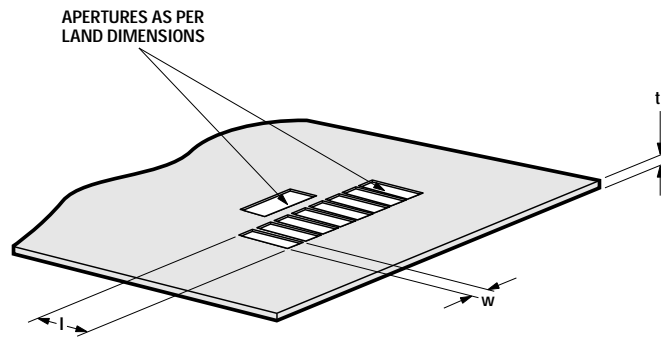

Figure 10. Solder stencil aperture.

Stencil thickness, t (mm)	Aperture size(mm)	
	length, l	width, w
0.152 mm	2.60 ± 0.05	0.55 ± 0.05
0.127 mm	3.00 ± 0.05	0.55 ± 0.05

1.3 Adjacent Land Keepout and Solder Mask Areas

Adjacent land keepout is the **maximum space** occupied by the unit relative to the land pattern. There should be no other SMD components within this area.

The minimum solder resist strip width required to avoid solder bridging adjacent pads is **0.2 mm**.

It is recommended that two fiducial crosses be placed at mid-length of the pads for unit alignment.

Note: Wet/Liquid Photo-Imageable solder resist/mask is recommended.

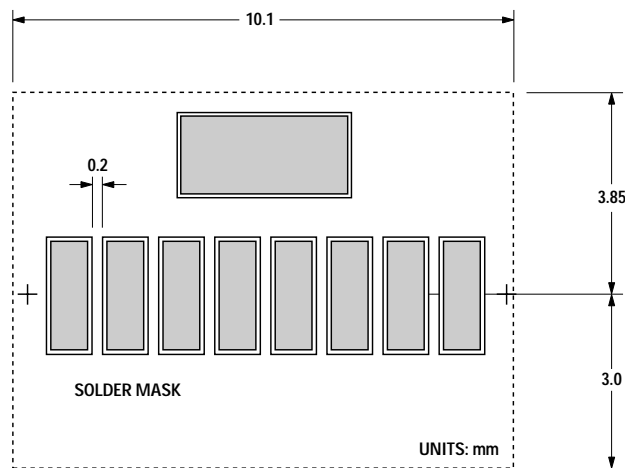

Figure 11. Adjacent land keepout and solder mask areas.

Appendix B: PCB Layout Suggestion

The following PCB layout guidelines should be followed to obtain a good PSRR and EM immunity resulting in good electrical performance. Things to note:

1. The ground plane should be continuous under the part, but should not extend under the shield trace.
2. The shield trace is a wide, low inductance trace back to the system ground.

3. VLED can be connected to either unfiltered or unregulated power supply. If VLED and Vcc share the same power supply, CX3 need not be used and the connections for CX1 and CX2 should be before the current limiting resistor R1. In a noisy environment, including capacitor CX2 can enhance supply rejection. CX1 is generally a ceramic capacitor of low inductance providing a wide frequency response while CX2 and CX3 are tantalum capacitors of big

volume and fast frequency response. The use of a tantalum capacitor is more critical on the VLED line, which carries a high current.

4. Preferably a multi-layered board should be used to provide sufficient ground plane. Use the layer underneath and near the transceiver module as Vcc, and sandwich that layer between ground connected board layers. Refer to the diagram below for an example of a four-layer board.

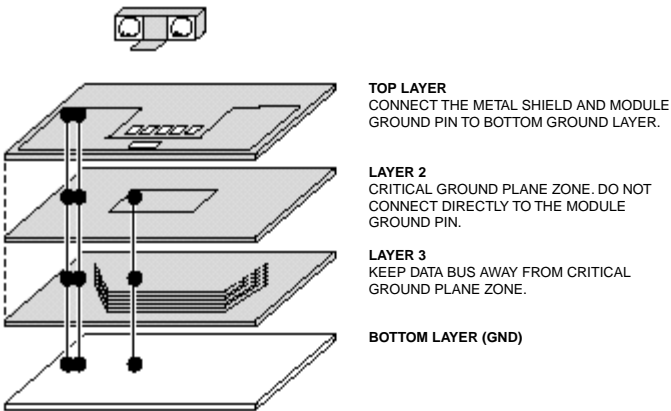

The area underneath the module at the second layer, and 3 cm in all directions around the module, is defined as the critical ground plane zone. The ground plane should be maximized in

this zone. Refer to application note AN1114 or the Agilent IrDA Data Link Design Guide for details. The layout below is based on a two-layer PCB.

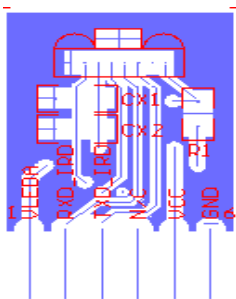

Top View



Bottom View

Appendix C: General Application Guide for the HSDL-3005 Infrared IrDA® Compliant 115.2 Kb/s Transceiver Description

The HSDL-3005, a wide-voltage operating range infrared transceiver is a low-cost and small form factor device that is designed to address the mobile computing market such as PDAs, as well as small embedded mobile products such as digital cameras and cellular phones. It is spectrally suited to universal remote control transmission function. It is fully compliant to IrDA 1.4 low power specification from 9.6 kb/s to 115.2 kb/s, and supports most remote control

codes. The design of the HSDL-3005 also includes the following unique features:

- Spectrally suited to universal remote control transmission function.
- Low passive component count.
- Shutdown mode for low power consumption requirement.

Selection of Resistor R1

Resistor R1 should be selected to provide the appropriate peak pulse LED current over different ranges of Vcc as shown on page 3 under "Recommended Application Circuit Components".

Interface to Recommended I/O Chips

The HSDL-3005's TXD data input is buffered to allow for CMOS drive levels. No peaking circuit or capacitor is required. Data rate from 9.6 kb/s up to 115.2 kb/s is available at the RXD pin. The TXD_RC, (pin 7), or the TXD_IrDA, (pin 3), can be used to send remote control codes.

The block diagrams below show how the IrDA port fits into a mobile phone and PDA platform.

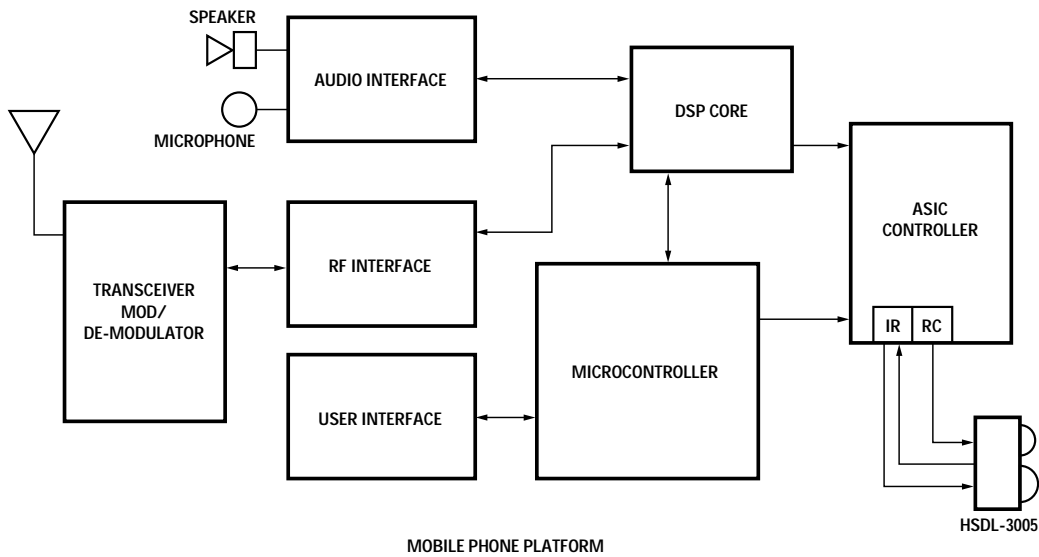

Figure 12. IR layout in mobile phone platform.

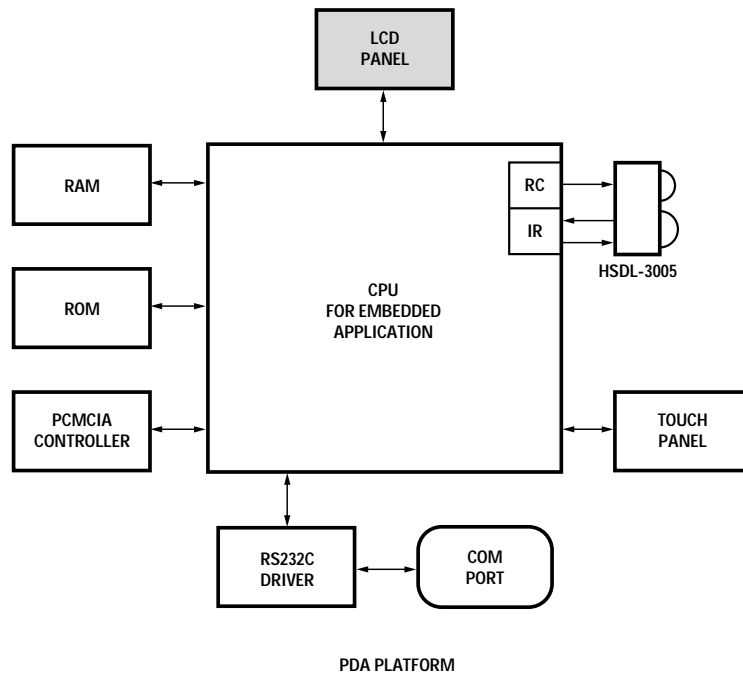

Figure 13. IR layout in PDA platform.

The link distance testing was done using typical HSDL-3005 units with SMC's FDC37C669 and FDC37N769 Super I/O controllers. An IrDA link distance of up to 70 cm was demonstrated.

Remote Control Operation

The HSDL-3005 is spectrally suited to universal remote control transmission function. Remote control applications are not governed by any standards, owing to which there are numerous remote control codes in the market. Each of these standards results in receiver

modules with different sensitivities, depending on the carrier frequencies and responsivity to the incident light wavelength.

Based on a survey of some commonly used remote control receiver modules, the irradiance is found to be in the range of 0.05 ~ 0.07 mW/cm². Based on a typical irradiance of 0.05 mW/cm² and 0.075 mW/cm² and turning on the RC LED, a typical link distance of 8 m and 7 m is achieved typically.

Appendix D: Window Designs for HSDL-3005

To ensure IrDA compliance, some constraints on the height and width of the window exist. The minimum dimensions ensure that the IrDA cone angles are met without vignetting. The maximum dimensions minimize the effects of stray light. The minimum size corresponds to a cone angle of 30 degrees, the maximum to a cone angle of 60 degrees.

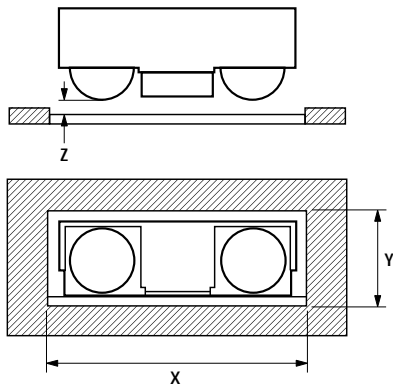

X is the width of the window, Y is the height of the window, and Z is the distance from the HSDL-3005 to the back of the window. The distance from the center of the LED lens to the center of the photodiode lens is 5.1 mm. The equations for the size of the window are as follows:

$$X = 5.1 + 2(Z + D) \tan \theta$$

$$Y = 2(Z + D) \tan \theta$$

Where θ is the required half angle for viewing. For the IrDA minimum, it is 15 degrees, for the IrDA maximum it is 30 degrees. (D is the depth of the LED image inside the part, 3.17 mm). These equations result in the following tables and graphs:

Minimum and Maximum Window Sizes

Dimensions are in mm.

Depth (Z)	Y min.	X min.	Y max.	X max.
0	1.70	6.80	3.66	8.76
1	2.23	7.33	4.82	9.92
2	2.77	7.87	5.97	11.07
3	3.31	8.41	7.12	12.22
4	3.84	8.94	8.28	13.38
5	4.38	9.48	9.43	14.53
6	4.91	10.01	10.59	15.69
7	5.45	10.55	11.74	16.84
8	5.99	11.09	12.90	18.00
9	6.52	11.62	14.05	19.15
10	7.06	12.16	15.21	20.31

Window Height Y vs. Module Depth Z

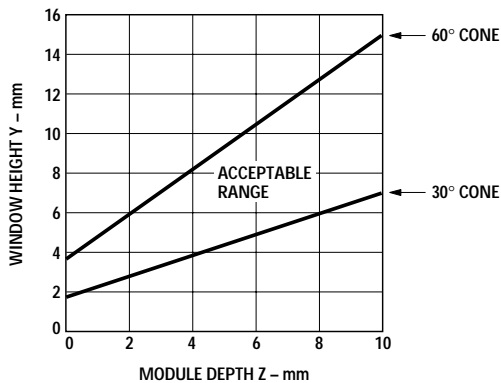

Window Width X vs. Module Depth Z

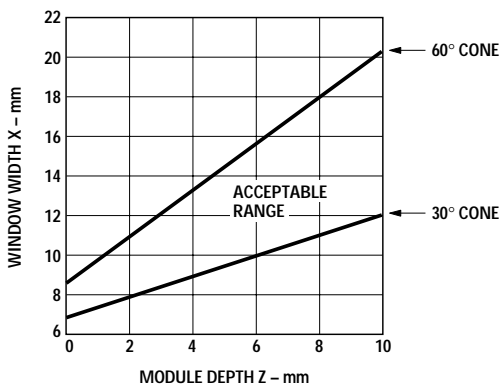

Window Material

Almost any plastic material will work as a window material. Polycarbonate is recommended. The surface finish of the plastic should be smooth, without any texture. An IR filter dye may be used in the window to make it look black to the eye, but the total optical loss of the window

should be 10% or less for best optical performance. Light loss should be measured at 875 nm. The recommended plastic materials for use as a cosmetic window are available from General Electric Plastics.

Recommended Plastic Materials:

Material #	Light Transmission	Haze	Refractive Index
Lexan 141	88%	1%	1.586
Lexan 920A	85%	1%	1.586
Lexan 940A	85%	1%	1.586

Note: 920A and 940A are more flame retardant than 141.
Recommended Dye: Violet #21051 (IR transmissant above 625 nm)

Shape of the Window

From an optics standpoint, the window should be flat. This ensures that the window will not alter either the radiation pattern of the LED, or the receive pattern of the photodiode.

If the window must be curved for mechanical or industrial design reasons, place the same curve on the back side of the window that has an identical radius as the front side. While this will not completely eliminate the lens effect of the front curved surface, it will significantly reduce the effects. The amount of change in the

radiation pattern is dependent upon the material chosen for the window, the radius of the front and back curves, and the distance from the back surface to the transceiver. Once these items are known, a lens design can be made which will eliminate the effect of the front surface curve.

The following drawings show the effects of a curved window on the radiation pattern. In all cases, the center thickness of the window is 1.5 mm, the window is made of polycarbonate plastic, and the distance from the transceiver to the back surface of the window is 3 mm.

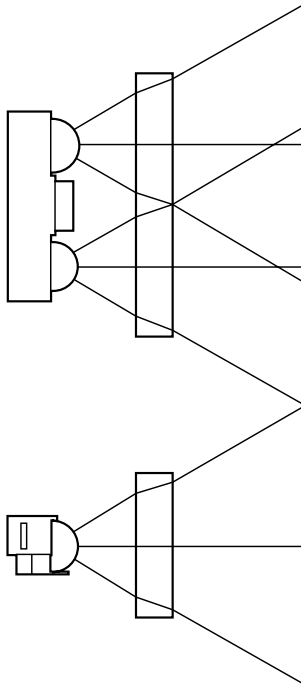

Flat Window
(First choice)

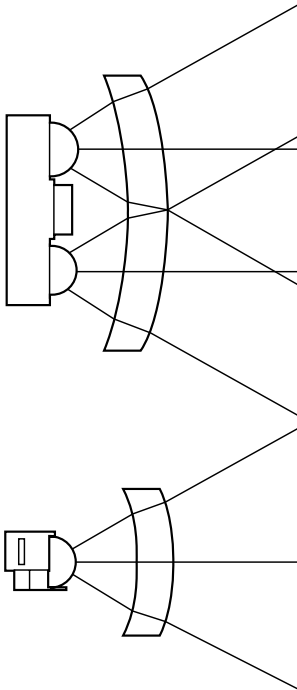

Curved Front and Back
(Second choice)

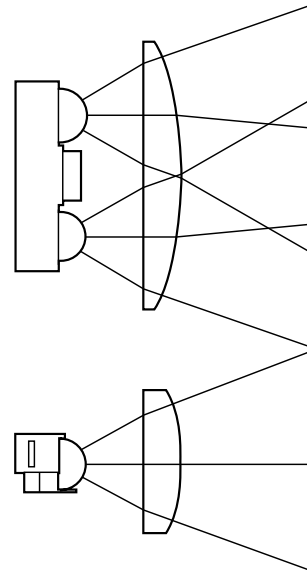

Curved Front, Flat Back
(Do not use)

www.agilent.com/semiconductors

For product information and a complete list of distributors, please go to our web site.

For technical assistance call:

Americas/Canada: +1 (800) 235-0312 or
(916) 788-6763

Europe: +49 (0) 6441 92460

China: 10800 650 0017

Hong Kong: (+65) 6756 2394

India, Australia, New Zealand: (+65) 6755 1939

Japan: (+81 3) 3335-8152 (Domestic/International), or 0120-61-1280 (Domestic Only)

Korea: (+65) 6755 1989

Singapore, Malaysia, Vietnam, Thailand,
Philippines, Indonesia: (+65) 6755 2044

Taiwan: (+65) 6755 1843

Data subject to change.

Copyright © 2004 Agilent Technologies, Inc.

August 24, 2004

5989-0729EN



Agilent Technologies