

OV6620 SINGLE-CHIP CMOS CIF COLOR DIGITAL CAMERA OV6120 SINGLE-CHIP CMOS CIF B&W DIGITAL CAMERA

Features

- 101,376 pixels, 1/4" lens, CIF/QCIF format
- Progressive scan read out
- Data format - YCrCb 4:2:2, GRB 4:2:2, RGB Raw Data
- 8/16 bit video data: CCIR601, CCIR656, ZV port
- Wide dynamic range, anti-blooming, zero smearing
- Electronic exposure / Gain / white balance control
- Image enhancement - brightness, contrast, gamma, saturation, sharpness, window, etc.
- Internal/external synchronization
- Frame exposure/line exposure option
- 5-Volt operation, low power dissipation
 - < 80 mW active power
 - < 10 μ A in power-save mode
- Gamma correction (0.45/0.55/1.00)
- SCCB programmable (400 kb/s):
 - color saturation, brightness, contrast, white balance, exposure time, gain

General Description

The OV6620 (color) and OV6120 (black and white) CMOS Image sensors are single-chip video/imaging camera devices designed to provide a high level of functionality in a single, small-footprint package. Both devices incorporate a 352 x 288 image array capable of operating up to 60 frames per second image capture. Proprietary sensor technology utilizes advanced algorithms to cancel Fixed Pattern Noise (FPN), eliminate smearing, and drastically reduce blooming. All needed

camera functions including exposure control, gamma, gain, white balance, color matrix, windowing, and more, are programmable through an SCCB (Serial Camera Control Bus) interface. Both devices can be programmed to provide image output in either 4-, 8- or 16-bit digital formats.

Applications include: Video Conferencing, Video Phone, Video Mail, Still Image, and PC Multimedia.

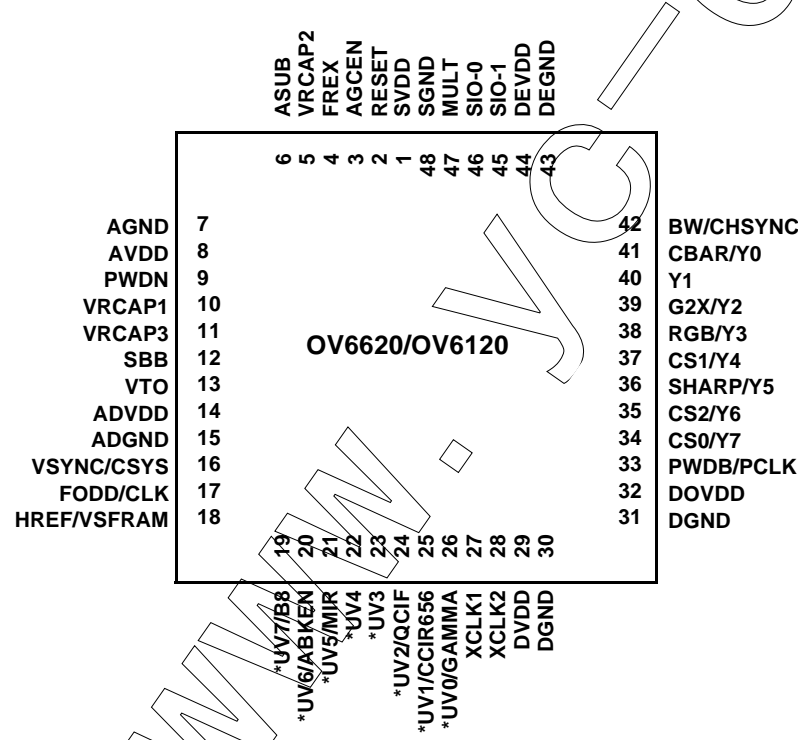

* Note: Outputs UV0-UV7 are not available on the OV6120. The inputs associated with these respective pins are still functional.

OV6620/OV6120 PIN ASSIGNMENTS

Array Elements (CIF) (QCIF)	356 x 292 (176 x 144)
Pixel Size	9.0 x 8.2 μ m
Image Area	3.1 x 2.5 mm
Max Frames/Sec	Up to 60 FPS
Electronic Exposure	Up to 500 : 1 (for selected FPS)
Scan Mode	progressive
Gamma Correction	0.45/0.55/1.0
Min. Illumination (3000K)	OV6620 - < 3 lux @ f1.2 OV6120 - < 0.5 lux @ f1.2
S/N Ratio (Digital Camera Out)	> 48 dB (AGC = Off, Gamma = 1)
FPN	< 0.03% $V_{p,p}$
Dark Current	< 0.2 nA/cm ²
Dynamic Range	> 72 dB
Power Supply	5VDC, \pm 5% (Anal.) 5VDC or 3.3VDC (DIO)
Power Requirements	< 80mW Active < 30 μ W Standby
Package	48 pin LCC

Table 1. Pin Description

Pin No.	Name	Pin Type	Function/Description
01	SVDD	V _{in}	Array power (+5VDC)
02	RESET	Function (Default = 0)	Chip Reset, active high
03	AGCEN	Function (Default = 0)	Automatic Gain Control (AGC) selection "0" - Disable AGC "1" - Enable AGC NOTE: This function is disabled when OV6620/OV6120 sensor is configured in SCCB mode.
04	FREX	Function (Default = 0)	Frame Exposure Control "0" - Disable Frame Exposure Control "1" - Enable Frame Exposure Control
05	VRCAP2	V _{ref} (2.5V)	Array reference. Connect to ground through 0.1 uF capacitor.
06	ASUB	V _{in}	Analog substrate voltage
07	AGND	V _{in}	Analog ground
08	AVDD	V _{in}	Analog power supply (+5VDC)
09	PWDN	Function (Default = 0)	Power down mode selection "0" - normal mode "1" - power down mode
10	VrCAP1	N/C	Internal voltage reference. Connect to ground through 0.1 μF capacitor.
11	VrCAP3		Internal voltage reference. Connect to ground through 1 μF capacitor.
12	SBB	Function (Default = 0)	SCCB (Serial Camera Control Bus) enable selection "0" - Enable SCCB "1" - Enable autocontrol mode
13	VTO	O	Luminance Composite Signal Output
14	ADVDD	V _{in}	Analog power supply (+5VDC)
15	ADGND	V _{in}	Analog signal ground
16	VSYNC/CSYS	I/O	Vertical sync output. At power up, read as CSYS.
17	FODD/CLK	I/O	Field ID FODD output or main clock output
18	HREF/VSFRAM	I/O	HREF output. At power up, read as VSFRAM
19	*UV7/B8	I/O	Bit 7 of U video component output. At power up, sampled as B8. * Note: Output UV7 is not available on the OV6120 sensor
20	*UV6/ABKEN	I/O	Bit 6 of U video component output. At power up, sampled as ABKEN. * Note: Output UV6 is not available on the OV6120 sensor
21	*UV5/MIR	I/O	Bit 5 of U video component output. At power up, sampled as MIR. * Note: Output UV5 is not available on the OV6120 sensor
22	*UV4	I/O	Bit 4 of U video component output. * Note: This output (UV4) is not available on the OV6120 sensor

OV6620/OV6120

SINGLE IC CMOS COLOR AND B/W DIGITAL CAMERAS

Table 1. Pin Description

Pin No.	Name	Pin Type	Function/Description
23	*UV3	I/O	Bit 3 of U video component output. <i>* Note: This output (UV3) is not available on the OV6120 sensor</i>
24	*UV2/QCIF	I/O	Bit 2 of U video component output. At power up, sampled as QCIF. <i>* Note: Output UV2 is not available on the OV6120 sensor</i>
25	*UV1/CC656	I/O	Bit 1 of U video component output. At power up, sampled as CC656. <i>* Note: Output UV1 is not available on the OV6120 sensor</i>
26	*UV0/GAMMA	I/O	Bit 0 of U video component output. At power up, sampled as GAMMA. <i>* Note: Output UV0 is not available on the OV6120 sensor</i>
27	XCLK1	I	Crystal clock input
28	XCLK2	O	Crystal clock output
29	DVDD	V _{in}	Digital power supply (+5VDC)
30	DGND	V _{in}	Digital ground
31	DOGND	V _{in}	Digital interface output buffer ground
32	DOVDD	V _{in}	Digital interface output buffer power supply (+5VDC)
33	PCLK/PWDB	I/O	PCLK output. At power up sampled as PWDB.
34	Y7/CS0	I/O	Bit 7 of Y video component output. At power up, sampled as CS0.
35	Y6/CS2	I/O	Bit 6 of Y video component output. At power up, sampled as CS2.
36	Y5/SHARP	I/O	Bit 5 of Y video component. At power up, sampled as SHARP.
37	Y4/CS1	I/O	Bit 4 of Y video component. At power up, sampled as CS1
38	Y3/RGB	I/O	Bit 3 of Y video component output. At power up, sampled as RGB.
39	Y2/G2X	I/O	Bit 2 of Y video component output. At power up, sampled as G2X.
40	Y1	I/O	Bit 1 of Y video component output.
41	Y0/CBAR	I/O	Bit 0 of Y video component output. At power up, sampled as CBAR.
42	CHSYNC/BW	I/O	CHSYNC output. At power up, sampled as BW.
43	DEGND	V _{in}	Decoder ground.
44	DEVDD	V _{in}	Decoder power supply (+5VDC)
45	SIO-1	I	SCCB serial interface clock input
46	SIO-0	I/O	SCCB serial interface data input and output.
47	MULT	Function (Default = 0)	SCCB slave selection "0" - Select single slave ID "1" - Enable multiple (8) slaves
48	SGND	V _{in}	Array ground

1. Functional Description

(Note: References to color features do not apply to the OV6120 B&W Digital Image Sensor.)

1.1 Overview

Referring to Figure 1, OV6620/OV6120 CMOS Image Sensor Block Diagram below, the OV6620 sensor includes a 356 x 292 resolution image array, an analog signal processor, dual 8-bit Analog-to-Digital converters, analog video multiplexer, digital data formatter and video port, SCCB interface and registers, digital controls including timing block, exposure, and black and white balance.

The OV6620/OV6120 sensor is a 1/4-inch CMOS imaging device. The sensor contains approximately 101,376 pixels. Its design is based on a field integration read-out system with line-by-line transfer and an electronic shutter with a synchronous pixel read out scheme. The color filter of the sensor consists of a primary color RG/GB array arranged in line-alternating fashion.

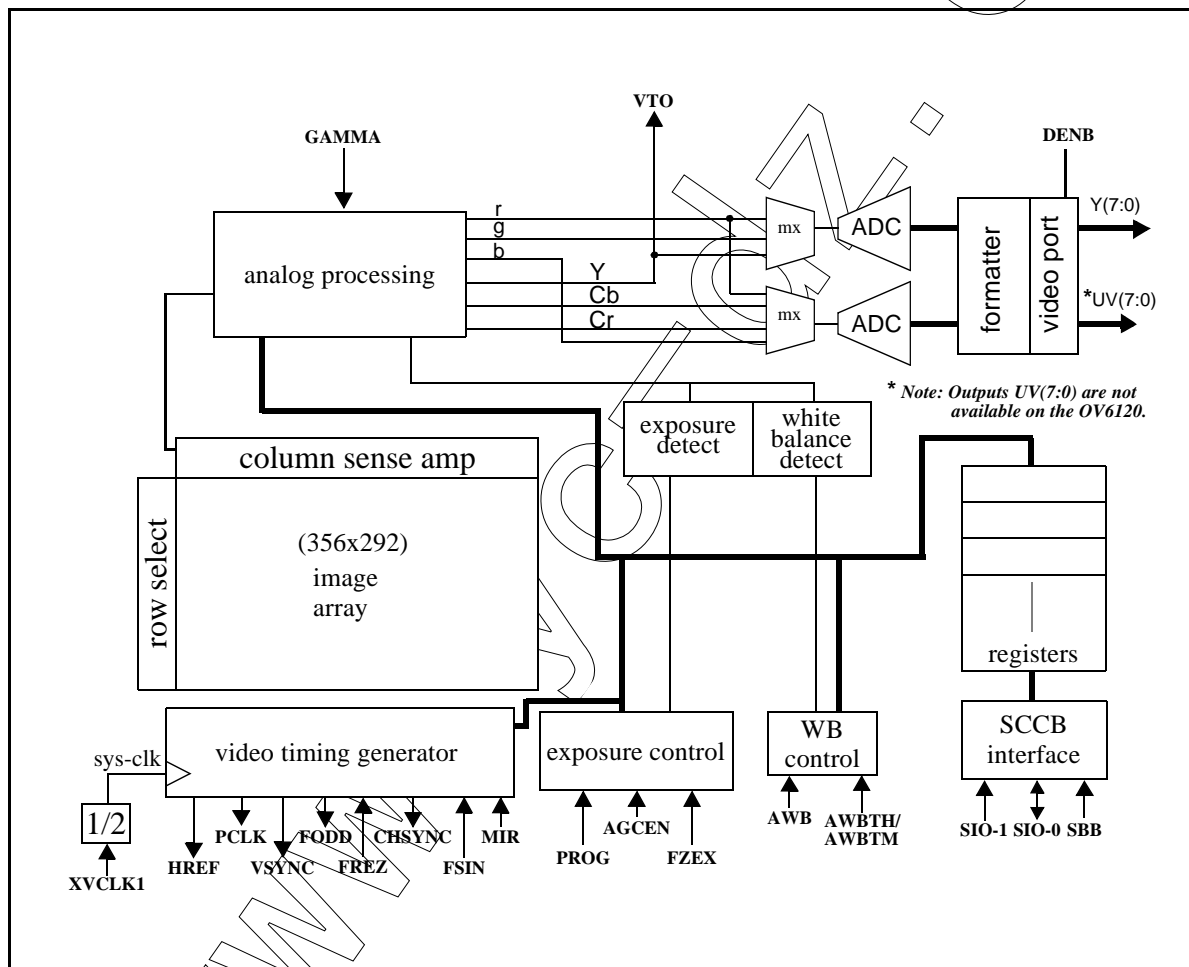

Figure 1. OV6620/OV6120 CMOS Image Sensor Block Diagram

1.2 Analog Processor Circuits

1.2.1 Overview

The image is captured by the 356 x 292 pixel image array and routed to the analog processing section where the majority of signal processing occurs. This block contains the circuitry which performs color separation, matrixing, Automatic Gain Control (AGC), gamma correction, color correction, color balance, black level calibration, "knee" smoothing, aperture correction, and controls for picture luminance, chrominance, and anti-alias filtering. The analog video signals are based on the following formula:

$$\begin{aligned} Y &= 0.59G + 0.31R + 0.11B \\ U &= R - Y \\ V &= B - Y \end{aligned}$$

where R,G,B are the equivalent color components in each pixel.

A YCrCb format is also supported, based on the formula below:

$$\begin{aligned} Y &= 0.59G + 0.31R + 0.11B \\ Cr &= 0.713 \times (R - Y) \\ Cb &= 0.564 \times (B - Y) \end{aligned}$$

The YCrCb/RGB Raw Data signal from the analog processing section is fed to two on-chip 8-bit Analog-to-Digital (A-to-D) converters: one for the Y/RG channel and one shared by the CrCb/BG channels. The A-to-D converted data stream is further conditioned in the digital formatter. The processed signal is delivered to the digital video port through the video multiplexer which routes the user-selected 16-, 8-, or 4-bit video data the correct output pins.

The on-chip 8-bit A-to-D converters operate at up to 9 MHz, fully synchronous to the pixel rate. Actual conversion rate is set as a function of the frame rate. A-to-D black-level calibration circuitry ensures the following:

- the black level of Y/RGB is normalized to a value of 16
- the peak white level is limited to 240
- CrCb black level is 128
- Peak/Bottom is 240/16
- RGB raw data output range is 16/240

(Note: Values 0 and 255 are reserved for sync flag)

1.2.2 Image Processing

The algorithm used for the electronic exposure control is based on the brightness of the full image. The exposure is optimized for a "normal" scene which assumes the subject is well lit relative to the background. In situations where the image is not well lit, the Automatic Exposure Control (AEC) White/Black ratio may be adjusted to suit the needs of the application.

Additional on-chip functions include Automatic Gain Control (AGC) which provides a gain boost of up to 24dB. White balance control enables setting of proper color temperature and can be programmed for automatic or manual operation. Separate saturation, brightness, contrast, and sharpness adjustments allow for further fine tuning of the picture quality and characteristics. The OV6620 image sensor also provides control over the White Balance ratio for increasing/decreasing the image field Red/Blue component ratio. The sensor provides a default setting which may be sufficient for many applications.

1.2.3 Windowing

The windowing feature of the OV6620/OV6120 image sensors allows user-definable window sizing as required by the application. Window size setting (in pixels) ranges from 2 x 2 to 356 x 292, and can be positioned anywhere inside the 356 x 292 boundary. Note that modifying window size and/or position does not change frame or data rate. The OV6620/OV6120 imager alters the assertion of the HREF signal to be consistent with the programmed horizontal and vertical region. The default output window is 352 x 288.

1.2.4 Zoom Video Port (ZV)

The OV6620/OV6120 image sensor includes a Zoom Video (ZV) function that supports standard ZV Port interface timing. Signals available include VSYNC, CHSYNC, PCLK and 16-bit data bus: Y[7:0] and UV[7:0]. The rising edge of PCLK clocks data into the ZV port. See Figure 2, Zoom Video Port Timing below.

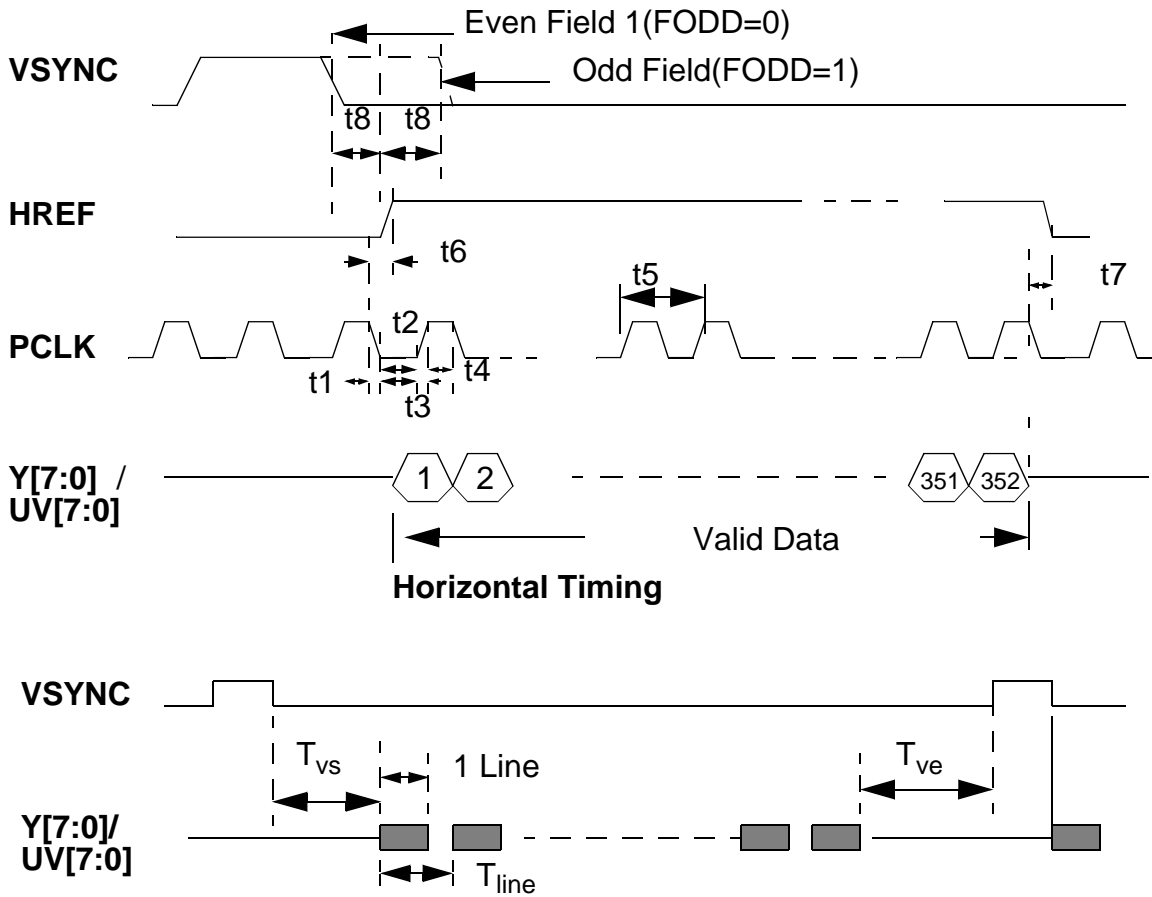

Figure 2. Zoom Video Port Timing

Notes:

- Zoom Video Port format output signal includes:
 - VSYNC: Vertical sync pulse.
 - HREF: Horizontal valid data output window.
 - PCLK: Pixel clock used to clock valid data and CHSYNC into Zoom V Port. Default frequency is 8.86MHz when use 17.73MHz as system clock. Rising edge of PCLK is used to clock the 16 Bit data.
 - Y[7:0]: 8 Bit luminance data bus.
 - UV[7:0]: 8 Bit chrominance data bus.
- All timing parameters are provided in Table 13. Zoom Video Port AC Parameters

1.2.5 QCIF Format

A QCIF mode is available for applications where high resolution image capture is not required. When programmed in this mode, the pixel rate is reduced by one-half. Default resolution is 176 x 144 pixels and can be user-programmed for other resolutions. Refer to Table 7. QCIF Digital Output Format (YUV, beginning of line) and Table 8. QCIF Digital Output Format (RGB Raw Data, Beginning of Line) for further information.

1.2.6 Video Output

The video output port of the OV6620/OV6120 image sensors provides a number of output format/standard options to suit many different application requirements. Table 2. Digital Output Formats, below, indicates the output formats available. These formats are user programmable through the SCCB interface (See Section 3.1 SCCB Bus Protocol Format).

The OV6620/OV6120 imager supports both CCIR601 and CCIR656 output formats in the following configurations (See Table 3. 4:2:2 16-bit Format for further details):

- 16-bit, 4:2:2 format

(This mode complies with the 60/50 Hz CCIR601 timing standard. See Table 3. 4:2:2 16-bit Format below)

- 8-bit data mode

(In this mode, video information is output in Cb Y Cr Y order using the Y port only and running at twice the pixel rate during which the UV port is inactive. See Table 4. 4:2:2 8-bit Format below)

- 4-bit nibble mode

(In the nibble mode, video output data appears at bits Y4-Y7. The clock rate for the output runs at twice the normal output speed when in B/W mode, and 4 times the normal output speed when in color mode.)

- 704 x 288 format

(When programmed for this mode, the OV6620/OV6120 pixel clock is doubled and the video output sequence is Y0Y0Y1Y1 ... and U0U0V0V0 ... See Figure 3, Pixel Data Bus (YUV Output), below.)

The OV6620/OV6120 imaging devices provide VSYNC, HREF, PCLK, FODD, CHSYNC as standard output video timing signals.

The OV6620/OV6120 image sensor can also be programmed to provide video output in RGB Raw Data 16-bit/8-bit/4-bit format. The output sequence is matched to the OV6620 Color Filter Pattern (See Section Figure 4. Pixel Data Bus (RGB Output), below):

- Y channel output sequence is G R G R
- UV channel output sequence is B G B G

For 8-bit RGB Raw Data video output appears on the Y channel (with an output sequence of B G R G) and the UV channel is disabled.

In RGB Raw Data CCIR656 modes, the OV6620/OV6120 imager asserts SAV (Start of Active Video) and EAV (End of Active Video) to indicate the beginning and the ending of HREF window. As a result, SAV and EAV change with the active pixel window. The 8-bit RGB raw data is also accessible without SAV and EAV information.

The OV6620/OV6120 imagers offer flexibility in YUV output format. The devices may be programmed as standard YUV 4:2:2. These devices may be configured to "swap" the U V sequence. When swapped, the UV channel output format for 16-bit configurations becomes:

- V U V U...etc.

and for 8-bit configurations becomes:

- V Y U Y ...etc.

A third format is available for the 8-bit configurations and OV6620/OV6120 enables the Y/UV sequence swap:

- Y U Y V ...etc.

The OV6620 color single-IC camera can be configured for use as a black and white imaging device. In this mode, vertical resolution is greater than in color. Video data output is provided at the Y port (pins 34:41) and the UV port is tri-stated. The data (Y/RGB) output rate is equivalent to operating in 16-bit mode.

The Y/UV or RGB output byte MSB and LSB can be reverse-ordered on the OV6620/OV6120 device. The Y7 - Y0 default sequence sets Y7 as MSB and Y0 as LSB. Programming a reverse order configuration sets Y7 as LSB and Y0 is MSB, with bits Y2-Y6 reversed-ordered appropriately.

Table 2. Digital Output Formats

Resolution	Pixel Clock	352 x 288	704 x 288	176 x 144
YUV 4:2:2	16-bit	Y	Y	Y
	8-bit	Y	Y	Y
	CCIR656	Y	Y	Y
	Nibble	Y	Y	Y
RGB	16-bit	Y	Y	Y
	8-bit	Y	Y	Y
	CCIR656 ¹	Y	Y	Y
	Nibble	Y	Y	Y
Y/UV swap ²	16-bit			
	8-bit	Y	Y	Y
U/V swap	YUV ³	Y	Y	Y
	RGB ⁴	Y	Y	Y
YG	16-bit	Y	Y	Y
	8-bit			
One Line	16-bit	Y		
	8-bit			
MSB/LSB swap ⁵		Y	Y	Y

Notes:

("Y" indicates mode/combination is supported by OV6620/OV6120.)

- When in RGB CCIR656 format, output is 8 bits. SAV and EAV are inserted at the beginning and ending of HREF, which synchronize the acquisition of Vsync and Hsync. In this format, an 8-bit data bus configuration (without VSYNC and CHSYNC) may be used.
- Y/UV swap is valid only in 8-bit mode. Y channel output sequence is Y U Y V...
- In YUV format, U/V swap means UV channel output sequence swap. V U V U... for 16 bit; V Y U Y ... for 8-bit.
- In RGB format, U/V swap means neighbor row B R output sequence swap. Refer to RGB raw data output format for further details

Table 3. 4:2:2 16-bit Format

Data Bus	Pixel Byte Sequence					
Y7	Y7	Y7	Y7	Y7	Y7	Y7
Y6	Y6	Y6	Y6	Y6	Y6	Y6
Y5	Y5	Y5	Y5	Y5	Y5	Y5
Y4	Y4	Y4	Y4	Y4	Y4	Y4
Y3	Y3	Y3	Y3	Y3	Y3	Y3
Y2	Y2	Y2	Y2	Y2	Y2	Y2
Y1	Y1	Y1	Y1	Y1	Y1	Y1
Y0	Y0	Y0	Y0	Y0	Y0	Y0
UV7	U7	V7	U7	V7	U7	V7
UV6	U6	V6	U6	V6	U6	V6
UV5	U5	V5	U5	V5	U5	V5
UV4	U4	V4	U4	V4	U4	V4
UV3	U3	V3	U3	V3	U3	V3
UV2	U2	V2	U2	V2	U2	V2
UV1	U1	V1	U1	V1	U1	V1
UV0	U0	V0	U0	V0	U0	V0
Y FRAME	0	1	2	3	4	5
UV FRAME	0		2		4	

Table 4. 4:2:2 8-bit Format

Data Bus	Pixel Byte Sequence							
Y7	U7	Y7	V7	Y7	U7	Y7	V7	Y7
Y6	U6	Y6	V6	Y6	U6	Y6	V6	Y6
Y5	U5	Y5	V5	Y5	U5	Y5	V5	Y5
Y4	U4	Y4	V4	Y4	U4	Y4	V4	Y4
Y3	U3	Y3	V3	Y3	U3	Y3	V3	Y3
Y2	U2	Y2	V2	Y2	U2	Y2	V2	Y2
Y1	U1	Y1	V1	Y1	U1	Y1	V1	Y1
Y0	U0	Y0	V0	Y0	U0	Y0	V0	Y0
Y FRAME	0		1		2		3	
UV FRAME	0 1				2 3			

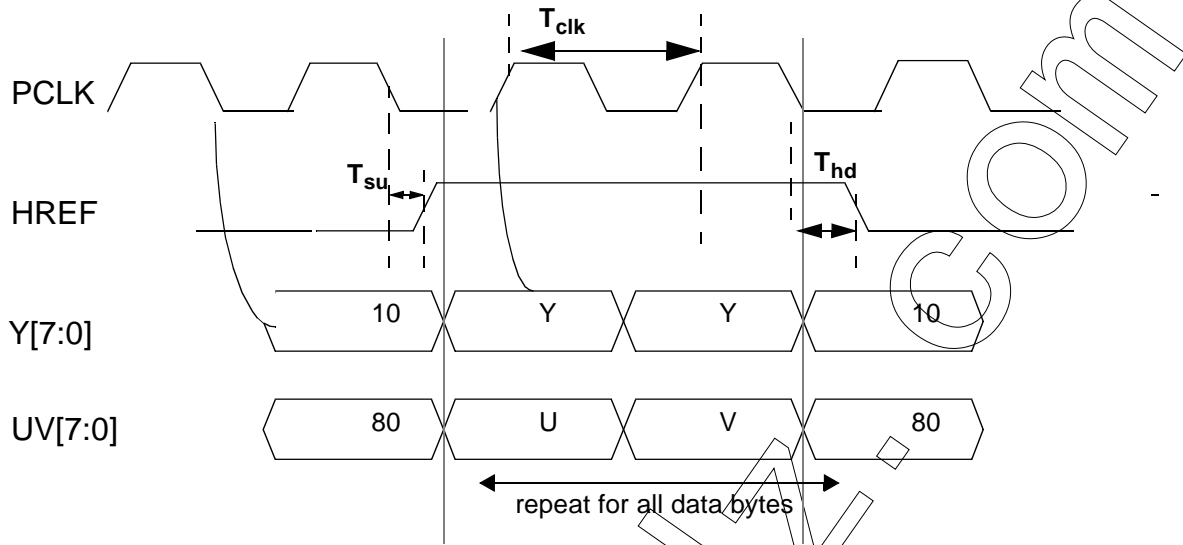

**Pixel Data 16-bit Timing
(PCLK rising edge latches data bus)**

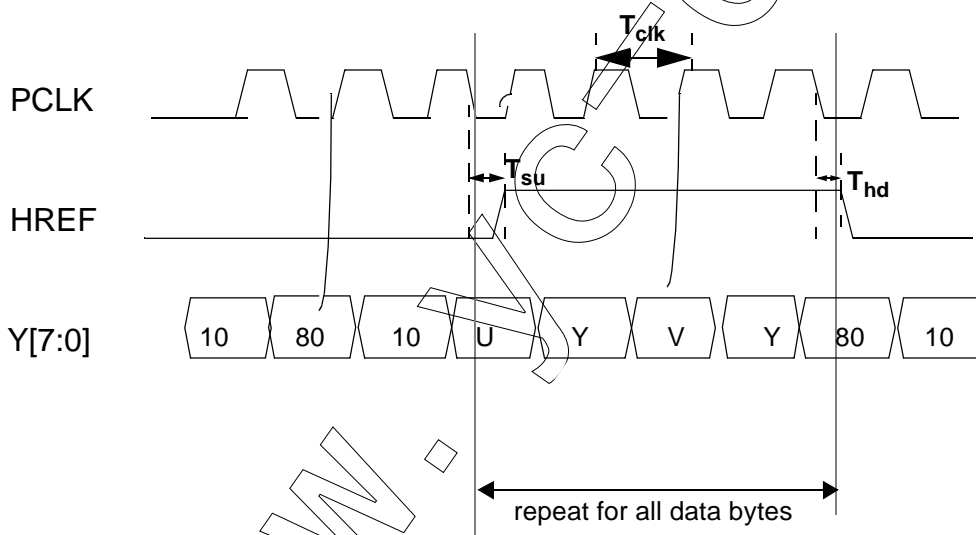

**Pixel Data 8-bit Timing
(PCLK rising edge latches data bus)**

Note: T_{clk} is pixel-clock period. When the OV6620 system clock is 17.73 MHz, $T_{clk} = 112$ ns for 16-bit output; $T_{clk} = 56$ ns for 8-bit output. T_{su} is HREF set-up time, maximum is 15 ns; T_{hd} is HREF hold time, maximum is 15 ns.

Figure 3. Pixel Data Bus (YUV Output)

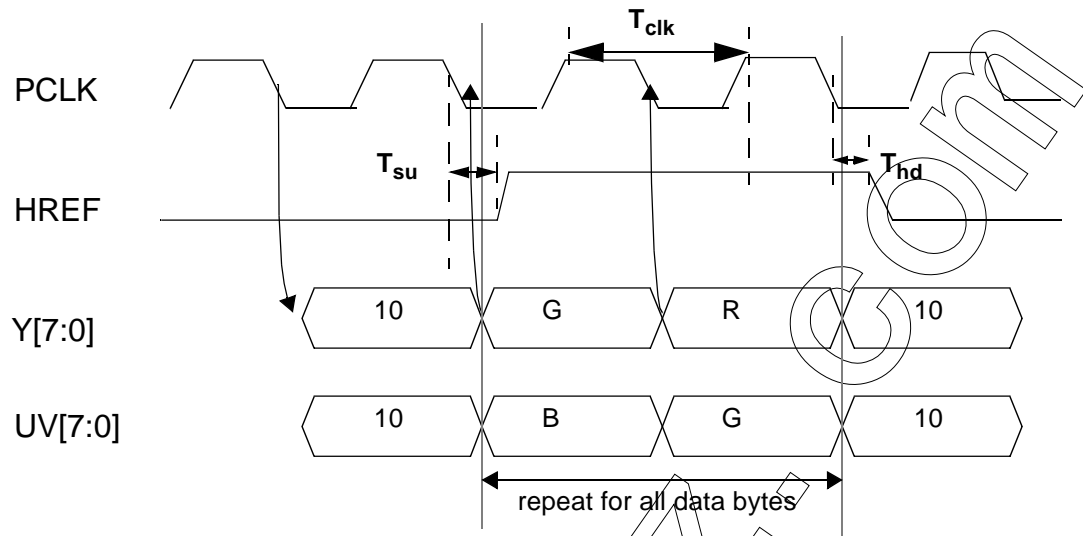

Pixel Data 16-bit Timing
PCLK rising edge latches data bus

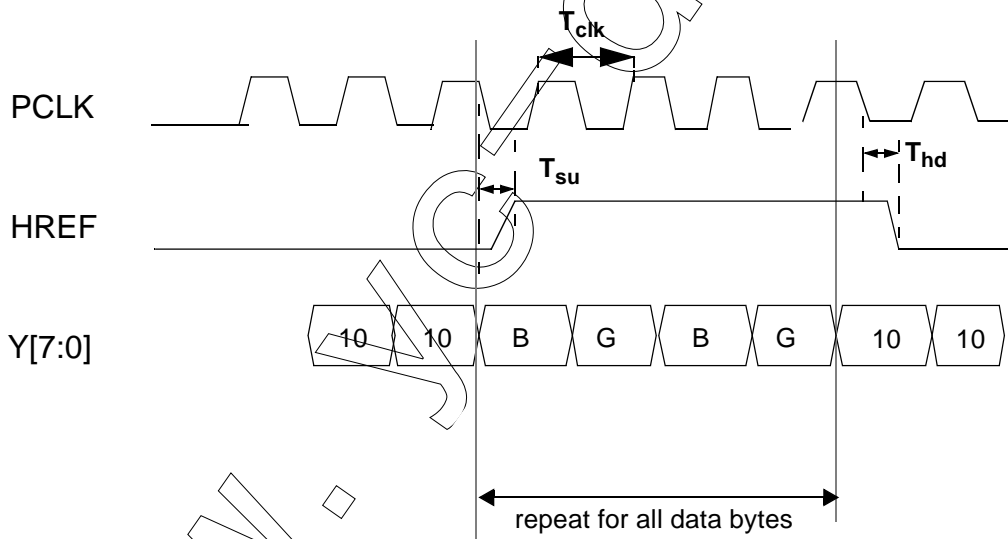

Pixel Data 8-bit Timing
PCLK rising edge latches data bus

Note: T_{clk} is pixel clock period. When the OV6620 system clock is 17.73MHz, $T_{clk} = 112\text{ns}$ for 16-bit output; $T_{clk} = 56\text{ns}$ for 8-bit output. T_{su} is HREF set-up time, maximum is 15 ns; T_{hd} is HREF hold time, maximum is 15 ns.

Figure 4. Pixel Data Bus (RGB Output)

MSB/LSB swap means: Default Y/UV channel output port relationship is:

Table 5. Default Output Sequence

	MSB							LSB
Output Port	Y7	Y6	Y5	Y4	Y3	Y2	Y1	Y0
Internal Output data	Y7	Y6	Y5	Y4	Y3	Y2	Y1	Y0

If the device is programmed for data swap, the sequence is changed to:

Table 6. Swapped MSB/LSB Output Sequence

	MSB							LSB
Output Port	Y7	Y6	Y5	Y4	Y3	Y2	Y1	Y0
Internal Output data	Y0	Y1	Y2	Y3	Y4	Y5	Y6	Y7

Table 7. QCIF Digital Output Format (YUV, beginning of line)

Pixel #	1	2	3	4	5	6	7	8
Y	Y0	Y1	Y2	Y3	Y4	Y5	Y6	Y7
UV	U0,V0	U1,V1	U2,V2	U3,V3	U4,V4	U5,V5	U6,V6	U7,V7

Y channel output Y2 Y3 Y6 Y7 Y10 Y11 ...

– UV channel output U2 V3 U6 V7 U10 V11 ...

– Every line output data number is half (176 pixels) and only one half line data (every other line, total 144 line) in one frame will be output.

Table 8. QCIF Digital Output Format (RGB Raw Data, Beginning of Line)

Pixel #	1	2	3	4	5	6	7	8
Line 1	B0	G1	B2	G3	B4	G5	B6	G7
Line 2	G0	R1	G2	R3	G4	R5	G6	R7

1. Default RGB two line output mode:

– Y channel output G0 R1 G4 R5 G8 R9 ...

– UV channel output B0 G1 B4 G5 B8 G9 ...

– Every line output half data (176 pixels) and all line (144 line) data in one frame will be output.

3. QCIF Resolution Digital Output Format

– Y channel output Y2 Y3 Y6 Y7 Y10 Y11 ...

– UV channel output U2 V3 U6 V7 U10 V11 ...

– Every line output data number is half (176 pixels) and only one half line data (every other line, total 144 line) in one frame will be output.

2. YG two line output mode:

– Y channel output G0 R1 G4 R5 G8 R9 ...

– UV channel output B0 G1 B4 G5 B8 G9 ...

– Every line outputs half data (176 pixels) and all line (144 line) data in one frame will be output.

Table 9. RGB Raw Data Format

R\C	1	2	3	4	.	353	354	355	356
1	B ₁₁	G ₁₂	B ₁₃	G ₁₄		B	G	B	G
2	G ₂₁	R ₂₂	G ₂₃	R ₂₄		G	R	G	R
3	B ₃₁	G ₃₂	B ₃₃	G ₃₄		B	G	B	G
4	G ₄₁	R ₄₂	G ₄₃	R ₄₄		G	R	G	R
5	B ₅₁	G ₅₂	B ₅₃	G ₅₄		B	G	B	G
.									
289	B	G	B	G		B	G	B	G
290	G	R	G	R		G	R	G	R
291	B	G	B	G		B	G	B	G
292	G	R	G	R		G	R	G	R

Notes:

A. Y port output data sequence: G R G R G R ... or G G G G ... ; UV port output data sequence: B G B G B G ... or B R B R ... ; Array Color Filter Patter is Bayer-Pattern

B. Output Modes

16-bit Format (HREF total 292)

Default mode:

- 1st HREF Y channel output unstable data, UV output B₁₁ G₁₂ B₁₃ G₁₄
- 2nd HREF Y channel output G₂₁ R₂₂ G₂₃ R₂₄ ..., UV output B₁₁ G₁₂ B₁₃ G₁₄ ...
- 3rd HREF Y channel output G₂₁ R₂₂ G₂₃ R₂₄ ..., UV output B₃₁ G₂₃ B₃₃ G₃₄
- Every line of data is output twice.

YG mode:

- 1st HREF Y and UV output unstable data.
- 2nd HREF Y channel output G₂₁ G₁₂ G₂₃ G₁₄ ..., UV output B₁₁ R₂₂ B₁₃ R₂₄ ...
- 3rd HREF Y is G₂₁ G₃₂ G₂₃ G₃₄ ..., UV channel is B₃₁ R₂₂ B₃₃ R₂₄ ...
- Every line data output twice.

One line mode:

- 1st HREF Y channel output B₁₁ G₁₂ B₁₃ G₁₄
- 2nd HREF Y channel output G₂₁ R₂₂ G₂₃ R₂₄
- UV channel tri-state.

8-bit Format (HREF total 292)

- 1st HREF Y channel output unstable data.
- 2nd HREF Y channel output B₁₁ G₂₁ R₂₂ G₁₂ ...
- 3rd HREF Y channel output B₃₁ G₂₁ R₂₂ G₃₂ ..., etc.
- PCLK timing is double and PCLK rising edge latch data bus. UV channel tri-state. Every line data output twice.

4-bit Nibble Mode Output Format

- Uses higher 4 bits of Y port (Y[7:4]) as output port.
- Supports YCrCb/RGB data, CCIR601/CCIR656 timing, Color/B&W.
- Output sequence: High order 4 bits followed by lower order 4 bits

Y0h Y0l Y1h Y1l ...
U0h U0l V0h V0l ...

For B/W or one-line RGB raw data, the output data clock speed is doubled. For color YUV, output clock is four times that of the 16-bit output data. In color mode, sensor must be set to 8-bit mode, and the nibble timing, clock divided by 2.

- Output sequence: U0h U0l Y0h Y0l V0h V0l Y1h Y1l ...

1.2.7 Slave Mode Operation

The OV6620/OV6120 sensors can be programmable to operate in slave mode configuration (COMI[6] = 1, default is master mode). HSYNC and VSYNC output signals are provided.

When used as a slave device, the external master must provide the OV6620/OV6120 imager with the following:

1. System clock CLK to XCLK1 pin;
2. Horizontal sync, Hsync, to CHSYNC pin, positive assertion;
3. Vertical frame sync, Vsync, to VSYNC pin, positive assertion

When in slave mode, the OV6620/OV6120 tri-states CHSYNC (pin 42) and VSYNC (pin 16) output pins, which may then be used as input pins. To synchronize multiple devices, the OV6620/OV6120 image sensors use external system clock, CLK, to synchronize external horizontal sync, HSYNC, which is then used to synchronize external vertical frame sync, Vsync. See Figure 5, Slave Mode External Sync Timing for timing considerations.

1.2.8 Frame Exposure Mode

The OV6620/OV6120 sensors support frame exposure mode when programmed for Progressive Scan. FREX (pin 4) is asserted by an external master device to set exposure time. When FREX = 1, the OV6620/OV6120 pixel array will be quickly precharged. Based on the external master's assertion of FREX, the OV6620/OV6120 devices capture the image. When the master de-asserts FREX (FREX = 0), the video output data stream is delivered to the OV6620/OV6120 output port in a line-by-line manner.

It should be noted that FREX must remain active long enough to ensure the complete image array has been precharged.

When data is being output from the OV6620/OV6120 image sensor, care must be taken so as not to expose the image array to light. This may affect the integrity of the image data captured. A mechanical shutter synchronized with the frame exposure rate can be used to minimize this situation. Frame exposure mode timing is shown in Section Figure 6. Frame Exposure Timing below.

1.2.9 Reset

The OV6620/OV6120 image sensors include a RESET pin (pin 2) which forces a complete hardware reset when

pulled high (Vcc). When a hardware reset occurs, the OV6620/OV6120 sensor clears all registers or sets them to their default values. Reset may also be initiated through the SCCB interface.

1.2.10 Power Down Mode

Two methods are available for placing the OV6620/OV6120 devices into power-down mode: hardware power down and SCCB/software power down.

To initiate hardware power down the PWDN pin (pin 9) must be tied to high (+5VDC). When this occurs, the OV6620/OV6120 internal device clock is halted and all internal registers (except SCCB registers) are reset. In this mode, current draw is less than 10uA.

Executing a software power down through the SCCB interface suspends internal circuit activity, but does halt the device clock. In this mode, current requirements drop to less than 1mA.

1.2.11 Configuring the OV6620/OV6120 Image Sensors

Two methods are provided for configuring the OV6620/OV6120 ICs for specific application requirements.

At power up, the OV6620/OV6120 sensors read the status of certain pins to determine what, if any, power up default settings are requested. Once the reading of the external pins is completed, the device configures its internal registers according to the specified pins. Not all device functions are available for configuration through external pin.

A more flexible and comprehensive method for configuring the OV6620/OV6120 ICs is to use its on-chip SCCB register programming capability. The SCCB interface provides access to all of the device's programmable internal registers. See Section 3.1 SCCB Bus for further details about using the SCCB interface on the OV6620/OV6120 camera device.

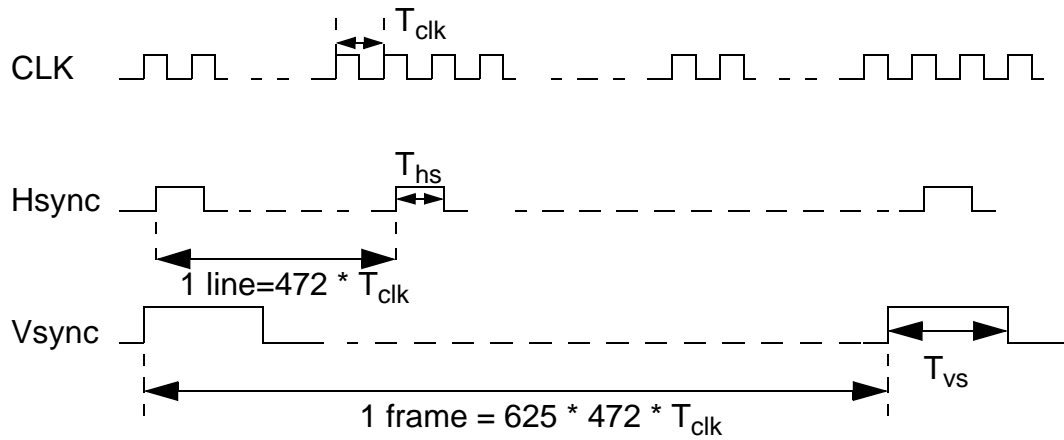

Notes:

1. $T_{hs} > 6 * T_{clk}$ (2) $T_{hs} < T_{vs} < 472 * T_{clk}$
2. Hsync period is 472 * CLK
3. Vsync period is 625 * 472 * CLK
4. OV6620 will be stable after 1 frame. (2nd Vsync).

Figure 5. Slave Mode External Sync Timing

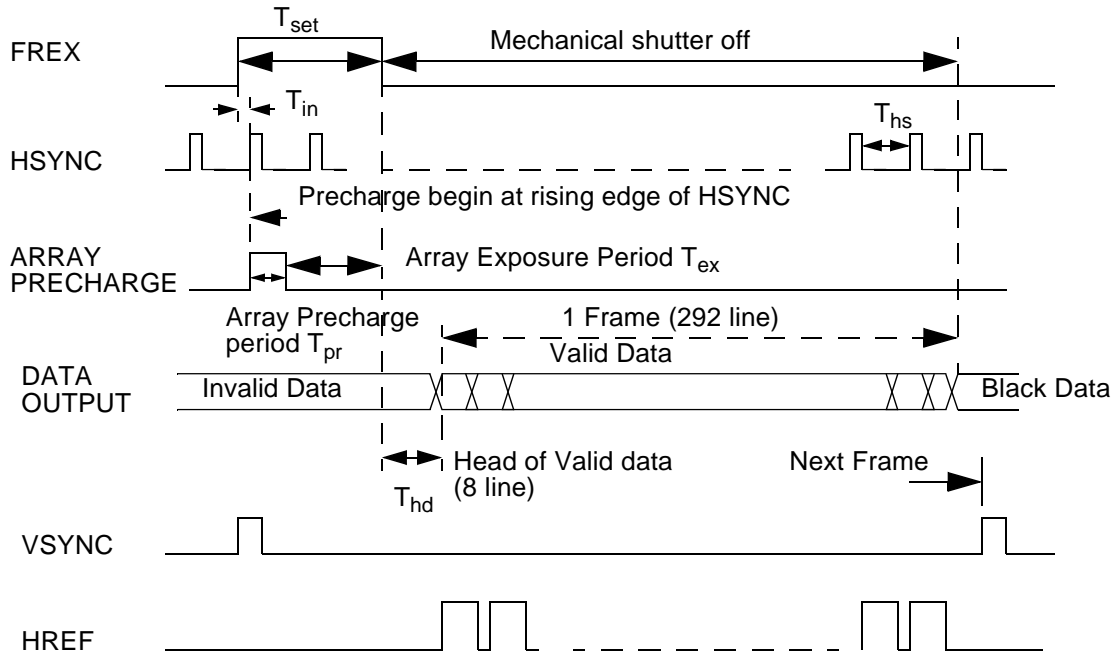

Note: $T_{pr} = 292 * 4 * T_{clk}$, T_{clk} is internal pixel period. For default 17.73 MHz, $T_{clk}=112$ us. If CLK[5:0] set to divided number, T_{clk} will increase accordingly.
 T_{ex} is array exposure time which is decided by external master device.
 T_{in} is uncertain time due to using **HSYNC** rising edge synchronize **FREX**, $T_{in} < T_{hs}$
 After **FREX=0**, there are 8 line data output before valid data output. $T_{hd} = 4 * T_{hs}$. Valid data is output when **HRE**
 $T_{set} = T_{in} + T_{pr} + T_{ex}$. $T_{set} > T_{pr} + T_{in}$. Because T_{in} is uncertain, so exposure time setting resolution is T_{hs} (one line).

Figure 6. Frame Exposure Timing

Normalized Spectrum Response

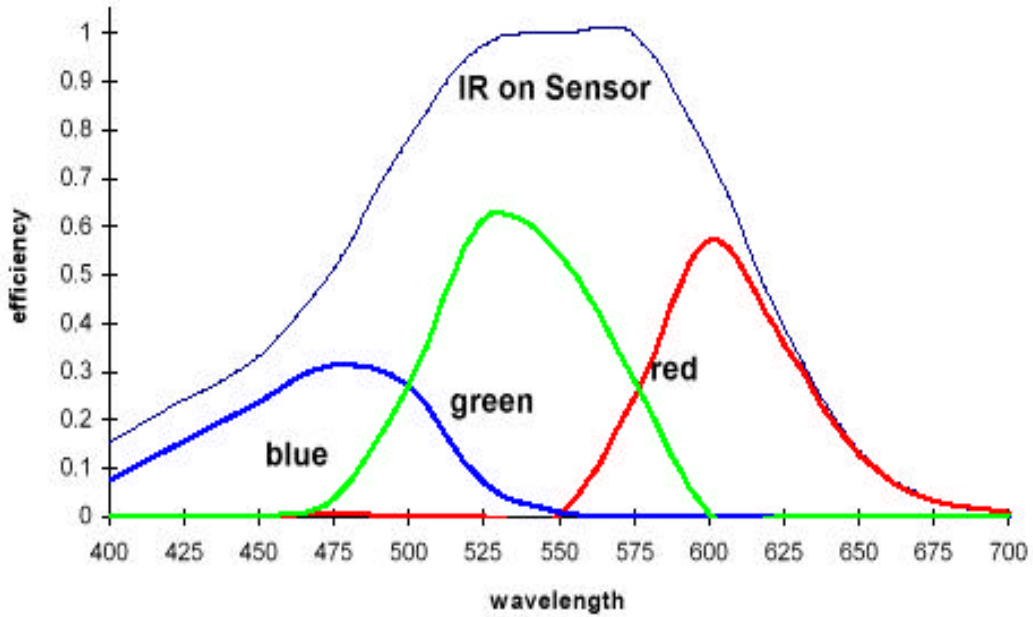

Monochrome Response

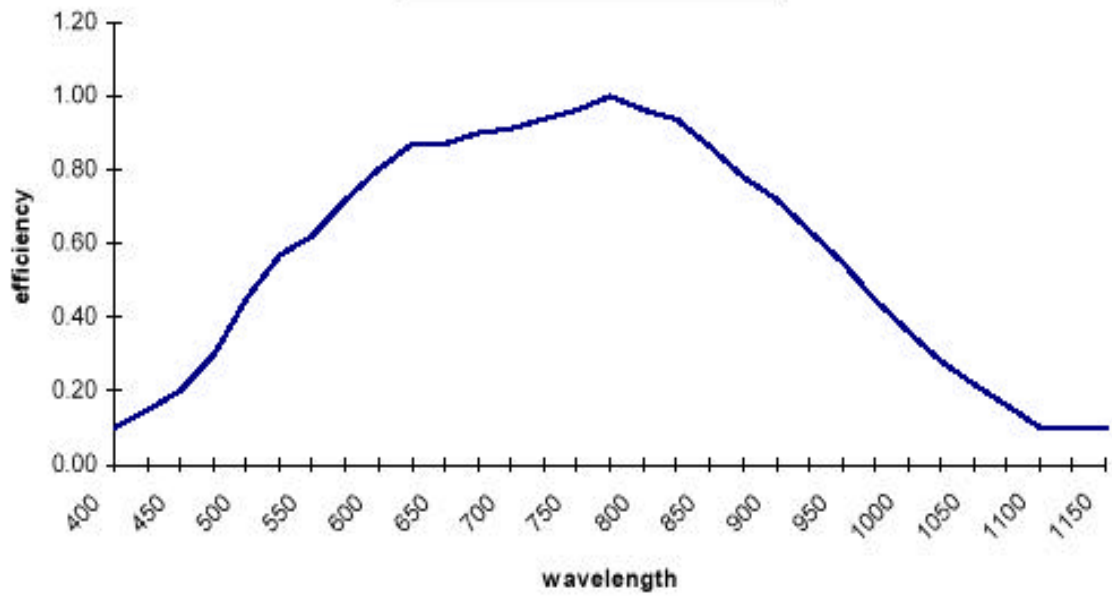

2. Electrical Characteristics**Table 10. DC Characteristics** ($0^{\circ}\text{C} \leq \text{TA} \leq 85^{\circ}\text{C}$, Voltages referenced to GND)

Symbol	Descriptions	Max	Typ	Min	Units
Supply					
V _{DD1}	Supply voltage- internal analog (DEVDD,ADVDD,AVDD,SVDD,AOVDD,DVDD)	5.25	5.0	4.75	V
V _{DD2}	Supply voltage - internal digital & output digital (DOVDD)	5.5 3.6	5.0 3.3	4.5 3.0	V V
I _{DD1}	Supply Current (@ 50Hz frame rate & 5 volt digital I/O, 25pf + 1TTL load on 16 bit data bus)	40	-	-	mA
I _{DD2}	Standby supply current	10	5	-	uA
Digital Inputs					
V _{IL}	input voltage LOW	0.8	-	-	V
V _{IH}	input voltage HIGH	-	-	2.0	V
C _{in}	input capacitor	10	-	-	pF
Digital Outputs - standard load 25pf, 1.2kΩ to 3.0volts					
V _{OH}	output voltage HIGH	-	-	2.4	V
V _{OL}	output voltage LOW	0.6	-	-	V
SCCB Inputs -					
V _{IL}	SIO-0 and SIO-1 (V _{DD2} =5V)	1.5	0	-0.5	V
V _{IH}	SIO-0 and SIO-1 (V _{DD2} =5V)	V _{dd} + .5	5	3.0	V
V _{IL}	SIO-0 and SIO-1 (V _{DD2} =3V)	1	0	-0.5	V
V _{IH}	SIO-0 and SIO-1 (V _{DD2} =3V)	3.5	3	2.5	V

Table 11. AC Characteristics ($T_A=25^\circ\text{C}$; $V_{dd}=5\text{V}$)

Symbol	Descriptions	Max	Typ	Min	Units
RGB/YCrCb output					
I _{so}	maximum sourcing current		15		mA
V _y	DC level at zero signal		1.2		V
	Y peak-peak 100% amplitude (without sync)		1		V
	sync amplitude		0.4		V
ADC parameters					
B	analog bandwidth				MHz
Φ_{diff}					
DLE	DC differential linearity error		0.5		LSB
ILE	DC integral linearity error		1		LSB

Table 12. Timing Characteristics

Symbol	Descriptions	Max	Typ	Min	Units
Oscillator & Clock in					
f _{osc}	frequency (XCLK1,XCLK2)	30	17.734	10	MHz
t _r , t _f	clock input rise/fall time	5			ns
	clock input duty cycle	55	50	45	%
SCCB timing(400kbit/s)					
t _{BUF}	Bus free time between STOP & START	-	-	1.3	ms
t _{HD:SAT}	SIO-1 change after START status	-	-	0.6	μs
t _{LOW}	SIO-1 low period	-	-	1.3	μs
t _{HIGH}	SIO-1 high period	-	-	0.6	μs
t _{HD:DAT}	Data hold time	-	-	0	μs
t _{SU:DAT}	Data set-up time	-	-	0.1	μs
t _{SU:STP}	Set-up time for STOP status	-	-	0.6	μs
Digital timing					
t _{pclk}	PCLK cycle time				
	16 bit operation	-	-	112	ns
	8 bit operation			56	ns

Table 12. Timing Characteristics

Symbol	Descriptions	Max	Typ	Min	Units
t_r, t_f	PCLK rise/fall time	15	-	-	ns
t_{pdd}	PCLK to data valid	15	-	-	ns
t_{phd}	PCLK to HREF delay	20	10	5	ns

Table 13. Zoom Video Port AC Parameters

Symbol	Parameter	Min.	Max.
t1	PCLK fall timing	4 ns	8 ns
t2	PCLK low time	50 ns	
t3	PCLK rise time	4 ns	8 ns
t4	PCLK high time	50 ns	
t5	PCLK period	106 ns	
t6	Y/UV/HREF setup time	10 ns	
t7	Y/UV/HREF hold time	20 ns	
t8	VSYNC setup/hold time to HREF	1 us	

Notes:

1. In Interlaced Mode, there are Even/Odd field different (t8). When In Progressive Scan Mode, only frame timing same as Even field(t8).
2. After VSYNC falling edge, OV6620 will output black reference level, the line number is T_{vs} , which is the line number between the 1st HREF rising edge after VSYNC falling edge and 1st valid data CHSYNC rising edge. Then valid data, then black reference, line number is T_{ve} , which is the line number between last valid data CHSYNC rising edge and 1st CHSYNC rising edge after VSYNC rising edge. The black reference output line number is dependent on vertical window setting.
3. When in default setting, $T_{vs} = 14 * T_{line}$, which is changed with register VS[7:0]. VS[7:0] step equal to 1 line.
4. When in default setting, $T_{ve} = 4 * T_{line}$ for Odd Field, $T_{ve} = 3 * T_{line}$ for Even Field, which is changed with register VE[7:0]. VE[7:0] step equal to 1 line.

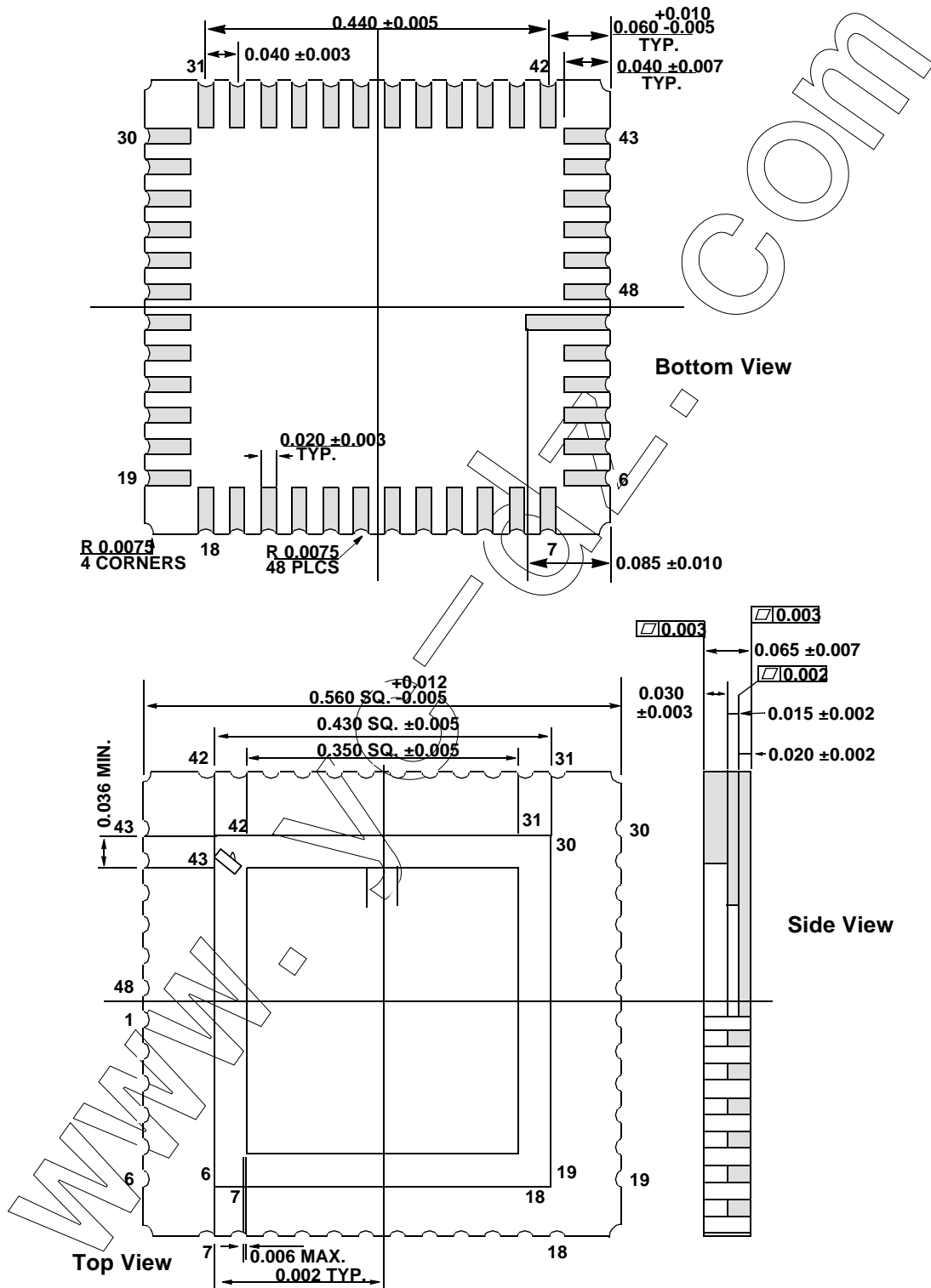

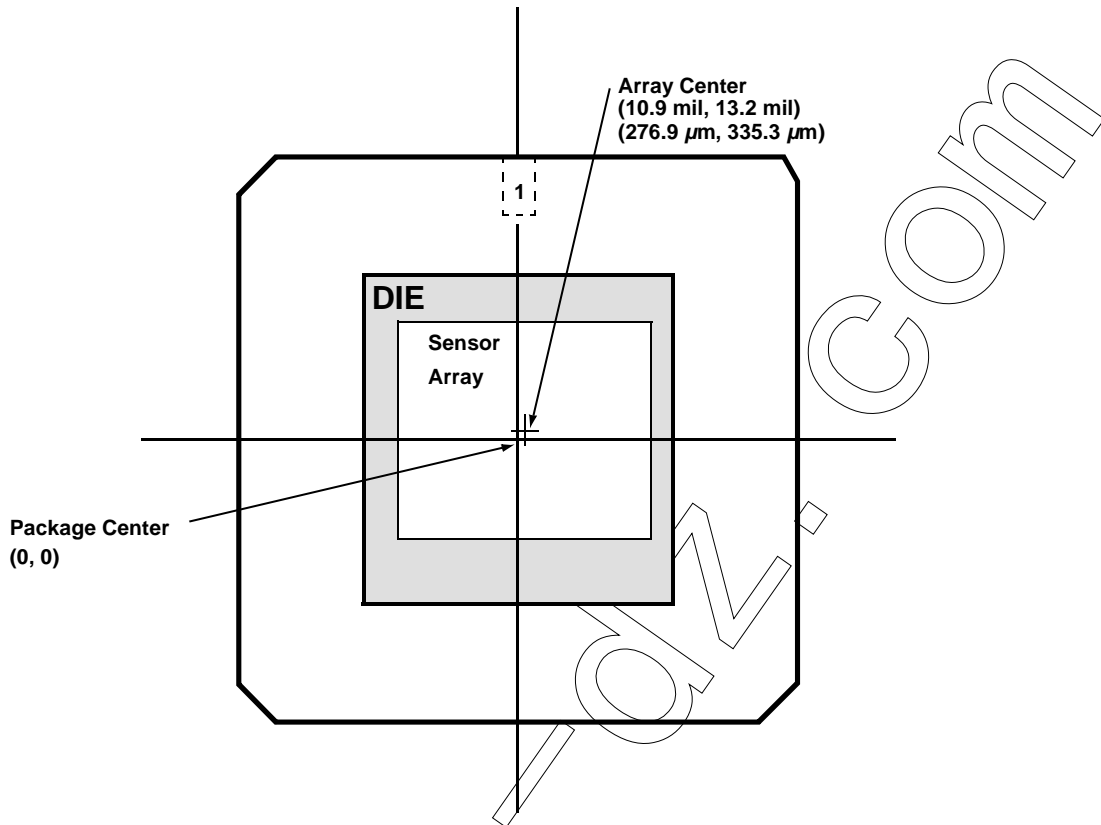

Figure 7. OV6620/OV6120 Package Outline

Table 14. Ordering Information

Part Number	Description	Package
OV6620	COLOR Image Sensor, CIF, Digital, SCCB Bus Control	48 pin LCC
OV6120	B/W Image Sensor, CIF, Digital, SCCB Bus Control	48 pin LCC

OmniVision Technologies, Inc. reserves the right to make changes without further notice to any product herein to improve reliability, function, or design. OmniVision Technologies, Inc. does not assume any liability arising out of the application or use of any product or circuit described herein; neither does it convey any license under its patent rights nor the rights of others. No part of this publication may be copied or reproduced, in any form, without the prior written consent of OmniVision Technologies, Inc.

OV6620/OV6120

SINGLE IC CMOS COLOR AND B/W DIGITAL CAMERAS

3. SCCB Bus

Many of the functions and configuration registers in the OV6620/OV6120 image sensors are available through the SCCB interface. The SCCB port is enabled by asserting the SBB line (pin 12) through a 10K ohm

resistor to V_{DD} . When the SCCB capability is enabled (SBB = 1), the OV6620/OV6120 imager operates as a slave device that supports up to 400 kbps serial transfer rate using a 7-bit address/data transfer protocol. Therefore, the OV6620/OV6120 sensor takes the read

subaddress from the previous write cycle. In multi-byte write or multi-byte read cycles, the subaddress is automatically increment after the first data byte so that continuous locations can be accessed in one bus cycle. A multi-byte cycle overwrites its original subaddress; therefore, if a read cycle immediately follows a multi-byte cycle, you must insert a single byte write cycle that provides a new subaddress..

3.1 SCCB Bus Protocol Format

Within each byte, MSB is always transferred first. Read/write control bit is the LSB of the first byte.

The protocol that SIO-0 remain stable during the HIGH period of the SIO-1. Each bit is allowed to change state only when SIO-1 is LOW. The OV6620/OV6120 SCCB supports multi-byte write and multi-byte read. The master must supply the subaddress. in the write cycle, but not in the read cycle.

Therefore, the OV6620/OV6120 sensor takes the read subaddress from the previous write cycle. In multi-byte write or multi-byte read cycles, the subaddress is automatically increment after the first data byte so that continuous locations can be accessed in one bus cycle. A multi-byte cycle overwrites its original subaddress; therefore, if a read cycle immediately follows a multi-byte cycle, you must insert a single byte write cycle that provides a new subaddress.

The OV6620/OV6120 imager can be programmed to one-of-eight slave ID addresses. Function pins CS[2:0] pins 35, 37, 34, respectively).

Table 15. Slave ID Addresses

CS[2:0]	000	001	010	011	100	101	110	111
WRITE ID (hex)	C0	C4	C8	CC	D0	D4	D8	DC
READ ID (hex)	C1	C5	C9	CD	D1	D5	D9	DD

The OV6620/OV6120 sensors support both single chip and multiple chip configurations. By asserting MULT (pin 47) high, the sensor can be programmed for up to 8 slave ID addresses. Asserting MULT low configures the OV6620/OV6120 imagers for single ID slave address with address C0 for writes and address C1 for reads. MULT is internally defaulted to a low condition.

In the write cycle, the second byte in SCCB bus is the subaddress for selecting the individual on-chip registers, and the third byte is the data associated with this register. Writing to unimplemented subaddress is ignored. In the read cycle, the second byte is the data associated with the previous stored subaddress. Reading of unimplemented subaddress returns unknown.

OV6620/OV6120

SINGLE IC CMOS COLOR AND B/W DIGITAL CAMERAS

3.2 Register Set

The table below provides a list and description of available SCCB registers contained in the OV6620/OV6120 image sensor.

Table 16. SCCB Registers

Subaddress (hex)	Register	Default (hex)	Read/Write	Descriptions
00	Gain[6:0]	00	RW	AGC Gain Control GC[7:6] - unimplemented bit, returns 'X' when read. GC[5:0] - Storage for the current AGC Gain setting. This register is updated automatically. If AGC is enabled, the internal control stores the optimal gain value in this register. If AGC is not enabled, a '00' is stored in this register.
01	Blue[7:0]	80	RW	Blue Gain Control BLU[7] - "0" decrease gain, "1" increase gain. BLU[6:0] - blue channel gain balance value. Note: This function is not available on the OV6120 Image Sensor.
02	Red[7:0]	80	RW	Red Gain Control RED[7] - "0" decrease gain, "1" increase gain. RED[6:0] - red channel balance value. Note: This function is not available on the OV6120 Image Sensor.

Subaddress (hex)	Register	Default (hex)	Read/Write	Descriptions
03	Sat	80	RW	Saturation Control SAT[7:0] - saturation adjustment. "FFh"- highest, "00h"-lowest Note: This function is not available on the OV6120 Image Sensor.
04	Rsvd04	XX	-	reserved
05	Cnt	48	RW	Contrast Control CTR[7:0] - contrast adjustment. "FFh"-highest, "00h"-lowest
06	Brt	80	RW	Brightness Control BRT[7:0] - brightness adjustment. "FFh"-highest,"00h"-lowest
07	Sharpness	C6	RW	Sharpness Control SHP[7:4] - Threshold of sharpness. Range: 0-80mV, Step: 5 mV SHP[3:0] - Sharpness control. Range: 0 - 8x, Step: 0.5x
08	Rsvd08	XX	-	reserved
09	Rsvd09	XX	-	reserved
0A	Rsvd0A	XX	-	reserved
0B	Rsvd0B	XX	-	reserved
0C	AWB - Blue	20	RW	White Balance Background: Blue Channel ABLU[7:6] - rsvd ABLU[5] - Sign bit. "0" - decrease background blue component "1" - increase background blue component ABLU[4:0] - White balance blue ratio adjustment Note: This function is not available on the OV6120 Image Sensor.

OV6620/OV6120

SINGLE IC CMOS COLOR AND B/W DIGITAL CAMERAS

Subaddress (hex)	Register	Default (hex)	Read/Write	Descriptions
0D	AWB - Red	20	R/W	White Balance Background: Red Channel ARED[7:6] - rsvd ARED[5] - Sign bit. "0" - decrease background red component "1" - increase background red component
0E	COMR	0D	RW	Common Control R COMR[7] - Analog signal 2x gain control bit. "1" - Additional 2x gain, "0" - normal COMR[6:0] - Reserved

Subaddress (hex)	Register	Default (hex)	Read/Write	Descriptions
0F	COMS	05	RW	Common Control S COMS[7:6] - Reserved COMS[5:4] - Black expanding level "00" - 1.2V, "01" - 1.26V, "10" - 1.3V, "11" - 1.4V COMS[3:2] - Set high threshold level "00" - 1.9V, "01" - 2.0V, "10" - 2.1V, "11" - 2.2V COMS[1:0] - Set low threshold level "00" - 1.3V, "01" - 1.45V, "10" - 1.5V, "11" - 1.6V

Subaddress (hex)	Register	Default (hex)	Read/Write	Descriptions
10	AEC	9A	R	Automatic Exposure Control AEC[7:0] - Set exposure time Interfaced: $T_{ex} = T_{line} \times AEC[7:0]$ Progressive: $T_{ex} = T_{line} \times AEC[7:0] \times 2$
11	CLKRC	00	R	Clock Rate Control CLKRC[7:5] - Sync output polarity selection "00" - HSYNC=Neg, CHSYNC=Neg, VSYNC=Pos "01" - HSYNC=Neg, CHSYNC=Neg, VSYNC=Neg "10" - HSYNC=Pos, CHSYNC=Neg, VSYNC=Pos "11" - HSYNC=Pos, CHSYNC=Pos, VSYNC=Pos CLKRC[5:0] - Clock prescaler $CLK = (CLK_main / ((CLKRC[5:0] + 1) \times 2)) / 2$
12	COMA	24	RW	Common Control A COMA[7] - SRST, "1" initiates soft reset. Initiate soft reset. All registers are set to default values and chip is reset to known state and resumes normal operation. This bit is automatically cleared after reset. COMA[6] - MIRR, "1" selects mirror image COMA[5] - VSFR, "1" enables AGC, COMA[4] - Digital output format, "1" selects 8-bit: Y U Y V Y U Y V COMA[3] - Select video data output: "1" - select RGB, "0" - select YCrCb COMA[2] - Auto White Balance "1" - Enable AWB, "0" - Disable AWB COMA[1] - Color Bar Test Pattern: "1" - Enable color bar test pattern COMA[0] - reserved Note: COMA[3] is not programmable on the OV6120 Image Sensor.

OV6620/OV6120

SINGLE IC CMOS COLOR AND B/W DIGITAL CAMERAS

Subaddress (hex)	Register	Default (hex)	Read/Write	Descriptions
13	COMB	01	RW	<p>Common Control B</p> <p>COMB[7] - reserved</p> <p>COMB[6] - reserved</p> <p>COMB[5] - Select data format. "1" - Select 8-bit format, Y/CrCb and RGB is multiplexed to 8-bit Y bus, UV bus is tri-stated, "0" - Select 16-bit format</p> <p>COMB[4] - "1" - enable digital output in CCIR656 format</p> <p>COMB[3] - CHSYNC output: "1" - Horizontal sync, "0" - composite sync</p> <p>COMB[2] - "1" - Tristate Y and UV busses. "0" - enable both busses</p> <p>COMB[1] - "1" - Initiate single frame transfer</p> <p>COMB[0] - "1" - Enable auto adjust mode</p> <p>Note: COMB[5] is not programmable on the OV6120 Image Sensor.</p>
14	COMC	00	RW	<p>Common Control C</p> <p>COMC[7] - reserved</p> <p>COMC[6] - reserved</p> <p>COMC[5] - QCIF digital output format selection. 1 - 176x144; 0 - 352x288.</p> <p>COMC[4] - Field/Frame vertical sync output in VSYNC port selection: 1 - frame sync, only ODD field vertical sync; 0 - field vertical sync, effect in Interlaced mode</p> <p>COMC[3] - HREF polarity selection: 0 - HREF positive effective, 1 - HREF negative.</p> <p>COMC[2] - gamma selection: 1 - RGB Gamma on ; 0 - gamma is 1.</p> <p>COMC[1] - reserved</p> <p>COMC[0] - reserved</p>
15	COMD	01	RW	<p>Common Control D</p> <p>COMD[7] - reserved bit.</p> <p>COMD[6] - PCLK polarity selection. "0" OV6620 output data at PCLK falling edge and data bus will be stable at PCLK rising edge; "1" rising edge output data and stable at PCLK falling edge. When OV6620 work as CCIR656 format, COMB4=1, this bit is disable and should use PCLK rising edge latch data bus.</p> <p>COMD[5:1] - reserved bit.</p> <p>COMD[0] - U V digital output sequence exchange control. 1 - UV UV ... for 16-bit, U Y V Y ... for 8-bit; 0 - V U V U ... for 16Bit and V Y U Y ... for 8 Bit.</p> <p>Note: COMD[0] is not programmable on the OV6120 Image Sensor.</p>
16	FSD	03	RW	<p>Field Slot Division</p> <p>FSD[7:2] - Field interval selection. Odd Even mode defined by FD[1:0]</p> <p>000000 - disable digital data output, only output black reference level.</p> <p>000001 - divide to 2 slots, HREF is active one in every 2 field/frame</p> <p>000010 - divide to 4 slots, HREF is active one in every 4 field/frame</p> <p>000100 - divide to 8 slots, HREF is active one in every 8 field/frame</p> <p>001000 - divide to 16 slots, HREF is active one in every 16 field/frame</p> <p>010000 - divide to 32 slots, HREF is active one in every 32 field/frame</p> <p>100000 - divide to 64 slots, HREF is active one in every 64field/frame</p> <p>FSD[1:0] - field mode selection. Each frame consists of two fields: Odd & Even, these bits defines the assertion of HREF in relation to the two fields.</p> <p>00 - OFF mode; HREF is not asserted in both fields, one exception is the single frame transfer operation (see the description for the register 13)</p> <p>01 - ODD mode; HREF is asserted in odd field only.</p> <p>10 - EVEN mode; HREF is asserted in even field only.</p> <p>11 - FRAME mode; HREF is asserted in both odd field and even field. FD[7:2] useless.</p>
17	HREFST	38	RW	<p>Horizontal HREF Start</p> <p>HS[7:0] - selects the starting point of HREF window, each LSB represents two pixels for CIF resolution mode, one pixels for QCIF resolution mode, this value is set based on an internal column counter, the default value corresponds to 352 horizontal window. Maximum window size is 356. see window description below. HS[7:0] programmable range is [38]- [EB], and should less than HE[7:0]. HS[7:0] should be programmable to value larger than or equal to [38]. Value larger than [EC] is invalid. See window description below.</p>
18	HREFEND	EA	RW	<p>Horizontal HREF End</p> <p>HE[7:0] - selects the ending point of HREF window, each LSB represents two pixels for full resolution and one pixels for QCIF resolution, this value is set based on an internal column counter, the default value corresponds to the last available pixel. The HE[7:0] programmable range is [39] - [EC]. HE[7:0] should be larger than HS[7:0] and less than or equal to [EC]. Value larger than [EC] is invalid. See window description below.</p>
19	VSTRT	03	RW	<p>Vertical Line Start</p> <p>VS[7:0] - selects the starting row of vertical window, in full resolution mode, each LSB represents 1 scan line in one frame. see window description below. Min. is [03], max. is [93] and should less than VE[7:0].</p>
1A	VEND	92	RW	<p>Vertical Line End</p> <p>VE[7:0]- selects the ending row of vertical window, in full resolution mode, each LSB represents 1 scan line in one frame, see window description below. Min. is [04], max. is [94] and should larger than VS[7:0].</p>

Subaddress (hex)	Register	Default (hex)	Read/Write	Descriptions
1B	PSHFT	00	RW	Pixel Shift PS[7:0] - to provide a way to fine tune the output timing of the pixel data relative to that of HREF, it physically shifts the video data output time late in unit of pixel clock as shown in the figure below. This function is different from changing the size of the window as is defined by HS[7:0] & HE[7:0] in register 17&18. Higher than default number shifts the pixel in delay(right) direction, the highest number is "FF". so maximum shift number is: Late: 256 pixels.
1C	MIDH	7F	R	Manufacture ID Byte: High MIDH[7:0] - read only, always returns "7F" as manufacturer's ID no.
1D	MIDL	A2	R	Manufacture ID Byte: Low MIDL[7:0] - read only, always returns "A2" as manufacturer's ID no.
1E	Rsvrd1E	C4	R	reserved
1F	Rsvrd1F	04	R	reserved
20	COME	00	RW	Common Control E COME[7] - HREF pixel number selection. "1" - HREF include 704 PCLK, every data output twice. COME[6] - reserved. COME[5] - "1" First stage aperture correction enable. Correction strength will be decided by register [07]. "0" disable first stage aperture correction. COME[4] - "1" Second stage aperture correction enable. Correction strength and threshold value will be decided by COMF[7] ~ COMF[4]. COME[3] - AWB smart mode enable. 1 - Drop out pixel when compare pixel red, blue and green component level to change register [01] and [02], which luminance level is higher than presetting level and lower than presetting level, this two level is set by register [0F]. 0 - calculate all pixels to get AWB result. Valid only when COMB[0]=1 and COMA[2]=1 COME[2] - AWB stop when field/frame image average luminance level is lower than a presetting level/enable. 1 - enable stop AWB when image luminance level is low. 0 - AWB is independent with field/frame luminance level. Valid only when COMB0=1 and COMA[2]=1. Average compare level is set by GAM[7:5]. COME[1] - AWB fast/slow mode selection. "1" - AWB is always fast mode, that is register [01] and [02] is changed every field/frame. "0" AWB is slow mode, [01] and [02] change every 16/64 field/frame decided by COMK[1]. When AWB enable, COMA[2]=1, AWB is working as fast mode at first 1024 field/frame, than as slow mode later. COME[0] - Digital output driver capability increase selection: "1" Double digital output driver current; "0" low output driver current status. Note: COME[3] (AWB Smart Mode), COME[2] (AWB Stop), and COME[1] (AWB Fast/Slow) are not programmable on the OV6120 Image Sensor.
21	YOFF	80	RW	Y Channel Offset Adjustment YOFF[7] - Offset adjustment direction 0 - Add Y[6:0]; 1 -Substrate Y[6:0]. YOFF[6:0] -Y channel digital output offset adjustment. Range: +127mV ~ -127mV. If COMG[2]=0, this register will be updated by internal auto A/D BLC circuit, and write a value to this register with SCCB has no effect. If COMG[2]=1, Y channel offset adjustment will use the register stored value which can be changed by SCCB. If COMF[1]=0, this register has no adjustment effect to A/D output data. If output RGB raw data, this register will adjust R/G/B data.
22	UOFF	80	RW	U Channel Offset Adjustment UOFF[7] - Offset adjustment direction: 0 - Add U[6:0]; 1 -Substrate U[6:0]. UOFF[6:0] - U channel digital output offset adjustment. Range: +128mV ~ -128mV. If COMG[2]=0, this register will be updated by internal auto A/D BLC circuit, and write a value to this register with SCCB has no effect. If COMG[2]=1, U channel offset adjustment will use the register stored value which can be changed by SCCB. If COMF[1]=1, this register has no effect to A/D output data. If output RGB raw data, this register will adjust R/G/B data. Note: This function is not available on the OV6120 Image Sensor.
23	REFC	04	RW	Reference Control REFC[7:6] - Select different crystal circuit power level (11 = minimum). REFC[5:4] - reserved REFC[3:0]: Reference Voltage range selection. 2.5V - 3.5V and step is 0.0625V.
24	AEW	33	RW	Automatic Exposure Control: Bright Pixel Ratio Adjustment AEW[7:0] - Used as calculate bright pixel ratio. OV6620 AEC algorithm is count whole field/frame bright pixel (its luminance level is higher than a fixed level) and black pixel (its luminance level is lower than a fixed level) number. When bright/black pixel ratio is same as the ratio defined by register [25] and [26], image stable. This register is used to define bright pixel ratio, default is 25%, each LSB represent step: 1.3% Change range is: [01] ~ [CA]; Increase AEW[7:0] will increase bright pixel ratio. For same light condition, the image brightness will increase if AEW[7:0] increase. Note: AEW[7:0] must combine with register [26] AEB[7:0]. The relation must be as follows: $AEW[7:0] + AEB[7:0] > [CA]$.

OV6620/OV6120

SINGLE IC CMOS COLOR AND B/W DIGITAL CAMERAS

Subaddress (hex)	Register	Default (hex)	Read/Write	Descriptions
25	AEB	97	RW	<p>Automatic Exposure Control: Black Pixel Ration Adjustment AEB[7:0] - used as calculate black pixel ratio. OV6620 AEC algorithm is count/whole field/frame bright pixel (its luminance level is higher than a fixed level) and black pixel (its luminance level is lower than a fixed level) number. When bright/black pixel ratio is same as the ratio defined by register [25] and [26], image stable. This register is used to define black pixel ratio, default is 75%, each LSB represent step: 1.3%; Change range is: [01] ~ [CA]; Increase AEB[7:0] will increase black pixel ratio. For same light condition, the image brightness will decrease if AEB[7:0] increase.</p> <p>Note: AEB[7:0] must be combined with register [25] AEW[7:0]. The relation must be as follows: EW[7:0] + AEB[7:0] > [CA].</p>
26	COMF	B0	RW	<p>Common Control F COMF[7:6] - Second aperture correction threshold selection. [00] - Difference of neighbor pixel luminance is larger than 8 mV, correction on. [01] - 16 mV. [10] - 32 mV. [11] - 64 mV. COMF[5:4] - Second aperture correction strength selection. [00] and [01] - Strength is 50% of difference of neighbor pixel luminance. [10] - 100%. [11] - 200%. COMF[3] - UV BLC swap. "1" swap; "0" no swap. COMF[2] - Digital data MSB/LSB swap. "1" LSB->Bit7, MSB->Bit0; "0" normal. COMF[1] - "1" A/D Black level calibration enable; "0" Disable A/D BLC. COMF[0] - "1" Output first 4 line black level before valid data output. HREF number will increase 4 relatively. "0" no black level output.</p>
27	COMG	A0	RW	<p>Common Control G COMG[7] - reserved COMG[6] - reserved. COMG[5] - Select CKOUT pin output V flag. 1 - CKOUT output V flag signal. CKOUT=1, means related UV channel output V component (or Red component), CKOUT=0 pointed to U component (or Blue component). 0 - CKOUT output buffered XCLK2 COMG[4] - reserved. COMG[3] - reserved. COMG[2] - "1" A/D offset adjustment manually mode enable: 1 - A/D data will be add/substrate a value defined by register [21] and [22], which content is written by SCCB. 0 - A/D data will be added/substrate a value defined by register [21] and [22], which is updated by internal circuit. COMG[1] - Digital output full range selection. OV6620 output data value range is [10] - [F0], if COMG[1]=1, range change to [01] - [FE] with signal overshoot and undershoot level. COMG[0] - reserved.</p>
28	COMH	01	RW	<p>Common Control H COMH[7] - "1" selects One-Line RGB raw data output format, "0" selects normal two-line RGB raw data output, effective only in Progressive Scan mode. COMH[6] - "1" enable Black/White mode. When OV6620 working as BW camera, its vertical resolution will be higher than color mode. At this mode, can't set OV6620 working at 8 bit output mode. OV6620 output data YUV/RGB from Y port. UV port will be tri-state. COMB[5] and COMB[4] will be set to "0". "0" normal color mode. COMH[5] - reserved. COMH[4] - Freeze AEC/AGC value, effective only when COMB0=1. "1" - register [00] and [10] will not be updated and hold latest value. "0" - AEC/AGC normal working status. COMH[3] - AGC disable. 1 - when COMB[0]=1 and COMA[5]=1, internal circuit will not update register [00], register [00] will kept latest updated value before COMH[3]=1. 0 - when COMB0=1 and COMA[5]=1, register [00] will be updated by internal algorithm. COMH[2] - RGB raw data output YG format: 1 - Y channel G, UV channel B R; 0 - Y channel: G R G R..., UV channel B G B G.... COMH[1] - Gain control bit. "1" Double PreAmp gain to 12dB. "0" PreAmp gain is 6dB. COMH[0] - High gain mode. "1" - AGC maximum gain is 24dB. AGC step is 1/8. "0" AGE maximum gain is 18dB, AGC step is 1/16. Only effective when COMB[0]=1, COMA[5]=1 and COMH[3]=0.</p> <p>Note: COMH[2] (RGB Raw Data) is not programmable on the OV6120 Image Sensor.</p>

OV6620/OV6120

SINGLE IC CMOS COLOR AND B/W DIGITAL CAMERAS

Subaddress (hex)	Register	Default (hex)	Read/Write	Descriptions
29	COMI	00	RW	Common Control I COMI[7]: - AEC disable. "1" If COMB[0]=1, AEC stop and register [10] value will be held at last AEC value and not be updated by internal circuit. "0" - if COMB[0]=1, register [10] value will be updated by internal circuit COMI[6]: - Slave mode selection. "1" slave mode, use external Sync and Vsync; "0" master mode COMI[5]: - reserved COMI[4]: - reserved COMI[3]: - Central 1/4 image area rather whole image used to calculate AEC/AGC. "0" use whole image area to calculate AEC/AGC. COMI[2]: - reserved COMI[1:0] - Version flag. For Version A, value is [00], these two bits can only be read.
2A	FRARH	84	RW	Frame Rate Adjust High FRARH[7] - Frame Rate adjustment enable bit. "1" Enable. FRARH[6] - reserved FRARH[5] - Highest 1bit of frame rate adjust control byte. see explanation below. FRARH[4] - reserved FRARH[3] - Y channel brightness adjustment enable. When COMF[2]=1 active. FRARH[2] - reserved FRARH[1] - "1" When in Frame exposure mode, only One frame data output. FRARH[0] - reserved
2B	FRARL	5E	RW	Frame Rate Adjust Low FRARL[7:0] - Lowest 8 bit of frame rate adjust control byte. Frame rate adjustment resolution is 0.21%. Control byte is 10 bit. Every LSB equal decrease frame rate 0.21%. Range is 0.21% - 109%. If frame rate adjustment enable, COME7 must set to "0".
2C	Rsvd2C	88	RW	reserved
2D	COMJ	03	RW	Common Control J COMJ[7:5] - reserved COMJ[4] - Enable auto black expanding mode. COMJ[3] - "1" = White Balance update when AGC/AEC stable. "0" = White Balance register update independent with AEC/AGC. COMJ[2] - Band filter enable. After adjust frame rate to match indoor light frequency, this bit enable a different exposure algorithm to cut light band induced by fluorescent light. COMJ[1] - reserved COMJ[0] - A/D U and V BLC separate mode. "1" = U and V offset cancelled by different register. "0" = U V offset cancelled by one common register [2E].
2E	VCOFF	80	RW	V Channel Offset Adjustment VCOFF[7]: Offset adjustment direction: "0" = Add V[6:0]; "1" = Substrate V[6:0]. VCOFF[6:0] - V channel digital output offset adjustment. Range: +128mV ~ -128mV. If COMC[2]=0, this register will be updated by internal auto A/D BLC circuit, and write a value to this register with SCCB has no effect. If COMG[2]=1, V channel offset adjustment will use the register stored value which can be changed by SCCB. If COMF[1]=1, this register has effect to A/D output data. If output RGB raw data, this register will adjust R/G/B data. Note: This function is not available on the OV6120 Image Sensor.
2F-32	Rsvd2F-Rsvd32	xx	-	Reserved
33	CPP	00	RW	Color Processing Parameter Control CPP[7:6] - reserved CPP[5] - Luminance gamma on/off. "1" - luminance gamma on; "0" - luminance gamma is 1. CPP[4:0] - reserved
34	BIAS	A2	RW	Bias Adjustment BIAS[7:6] - A/D reference level adjustment. [00] - 110% internal full signal range; [01] - 120%, [10] - 130%, [11] - 140%. BIAS[5:0] - reserved
35	Rsvd35	80	RW	reserved
36	Rsvd36	48	RW	reserved
37	Rsvd37	41	RW	reserved

OV6620/OV6120

SINGLE IC CMOS COLOR AND B/W DIGITAL CAMERAS

Subaddress (hex)	Register	Default (hex)	Read/Write	Descriptions
38	COMK	81	RW	<p>Common Control K</p> <p>COMK[7] - HREF edge latched by PCLK falling edge (When COMD[6] = 0). "0" HREF edge is 10 ns after PCLK rising edge.</p> <p>COMK[6] - Output port drive current additional 2x control bit.</p> <p>COMK[5] - reserved.</p> <p>COMK[4] - ZV port Vertical timing selection. "1" VSYNC output ZV port vertical-sync signal. "0" = normal TV vertical sync signal.</p> <p>COMK[3] - Quick stable mode when camera mode change. After relative control bit set, the first VS will be the stable image with suitable AEC/AWB setting. "0" - slow mode, after mode change need more field/frame to get stable AEC/AWB setting image.</p> <p>COMK[2] - reserved</p> <p>COMK[1] - AWB stable time selection when in slow mode. "1" - 4 times less time needed to get stable AWB setting when in slow AWB mode.</p> <p>COMK[0] - reserved.</p> <p>Note: COMK[1] (AWB Stable Time) is not programmable on the OV6120 Image Sensor.</p>
39	COML	00	RW	<p>Common Control L</p> <p>COML[7] - reserved</p> <p>COML[6] - PCLK output timing selection. 1 -- PCLK valid only when HREF is high; 0 -- PCLK is free running.</p> <p>COML[5] - Vertical sync selection, 1 -- Same period between 1st HREF and VS falling edge in two field; 0 - Different timing period between 1st HREF and VS falling edge</p> <p>COML[4] - "1" select CHSYNC output from HREF port. "0" normal</p> <p>COML[3] - "1" select HREF output from CHSYNC port. "0" normal</p> <p>COML[2] - Tristate all control signal/output (FODD, CHSYNC, HREF, PCLK)</p> <p>COML[1] - Highest 1 bit of horizontal sync starting position, combined with register [3A]</p> <p>COML[0] - Highest 1 bit of horizontal sync ending position, combined with register [3B]</p>
3A	HSST	0F	RW	<p>Horizontal Sync Start Position</p> <p>HSST[7:0] - lower 8 bit of horizontal sync starting position, combined with register bit of COML[1], total 9 bit control. range: [00] -- [FF]. HSEND[8:0] must less than HSST[8:0]</p>
3B	HSEND	3C	RW	<p>Horizontal Sync End Position</p> <p>HEND[7:0] - lower 8 bit of horizontal sync ending position, combined with register bit of COML[0], total 9 bit control. range: [00] -- [FF]. HSEND[8:0] must be larger than HSST[8:0]</p>
3C	COMM	21	RW	<p>Common Control M</p> <p>COMM[7:5] - Select minimum AEC number if Banding filter enable. [000] -- 1 field, [001] -- 1/2; [010] -- 1/4; [011] -- 1/8; [100] -- 1/16; [101]--[111] -- 1/32;</p> <p>COMM[4] - AEC/AGC change mode selection</p> <p>COMM[3] - AEC/AGC change mode selection</p> <p>COMM[2] - AEC/AGC change fastest mode</p> <p>COMM[1] - AEC/AGC change fast mode</p> <p>COMM[0] - AEC/AGC change slowest mode</p>
3D	COMN	08	RW	<p>Common Control N</p> <p>COMN[7] - Enable one frame drop when AEC change to keep data valid when Banding filter mode enable.</p> <p>COMN[6:4] - reserved</p> <p>COMN[3] - Enable 50 Hz PAL video timing, so VTO analog signal can be displayed on TV</p> <p>COMN[2:0] - reserved</p>
3E	COMO	80	RW	<p>Common Control O</p> <p>COMO[7] - Input main clock divided by 2 or 4 selection. 1 -- 2; 0 -- 4</p> <p>COMO[6:5] - reserved</p> <p>COMO[4] - Select 4 bit nibble mode output</p> <p>COMO[3] - reserved</p> <p>COMO[2] - Enable Minimum exposure time is 4 line. Default is 1 line</p> <p>COMO[1] - reserved</p> <p>COMO[0] - reserved</p>
3F	COMP	02	RW	<p>Common Control P</p> <p>COMP[7] - reserved</p> <p>COMP[6] - Output main clock output from FODD port</p> <p>COMP[5] - reserved</p> <p>COMP[4] - Software whole chip power down enable, can be waked up by disable this bit</p> <p>COMP[3:2] - reserved</p> <p>COMP[1] - CCIR656 output control</p> <p>COMP[0] - Reset internal timing circuit without reset AEC/AGC/AWB value</p>
40	Rsvd40 - Rsvd4C	XX	-	reserved

OV6620/OV6120

SINGLE IC CMOS COLOR AND B/W DIGITAL CAMERAS

Subaddress (hex)	Register	Default (hex)	Read/Write	Descriptions
4D	YMXA	02	RW	<p>YUV Matrix Control (Main) YMXA[7:5] - reserved YMXA[4:3] - YUV/YCrCb selection: [00] U = u, V = v [01] U = 0.938u, V = 0.838v [10] U = 0.563u, V = 0.714v [11] U = 0.5u, V = 0.877v YMXA[2:0] - Reserved</p> <p>Note: This function is not available on the OV6120 Image Sensor.</p>
4E	ARL	A0	RW	<p>AEC/AGC Reference Level ARL[7:5] - Reference Level Voltage Selection (Higher voltage = brighter final stable image) [000] = 1.3v [001] = 1.5v [010] = 1.6v [011] = 1.7v [100] = 1.8v [101] = 1.9v [110] = 2.0v [111] = 2.1v ARL[4:0] - Reserved</p>
4F	YMXB	00	RW	<p>YUV Matrix Control (Secondary) YMXB[7:6] - Y channel delay selection: 0 - 3 tp YMXB[5:4] - UV delay selection: 0 - 6 tp YMXB[3:2] - Select UV average mode. [00] & [10]: U0/V0 (no delay); [01] -- 3 point average; [11] -- 5 point average mode YMXB[1:0] - Color killer control: [00]:2.4v;[01]:2.6v;[10]:2.8v;[11]:3.0v</p> <p>Note: This function is not available on the OV6120 Image Sensor.</p>
50	Rsvd50 - Rsvd53	XX	-	reserved