

BFR90

**RF & MICROWAVE DISCRETE
 LOW POWER TRANSISTORS**

Features

- High Current-Gain – Bandwidth Product, $fT = 5.0 \text{ GHz}$ (typ) @ $I_C = 14 \text{ mA}$
- Low Noise Figure – $NF = 2.4 \text{ dB}$ (typ) @ $f = 0.5 \text{ GHz}$
- High Power Gain – $G_{max} = 18\text{dB}$ (typ) @ $f = 0.5 \text{ GHz}$

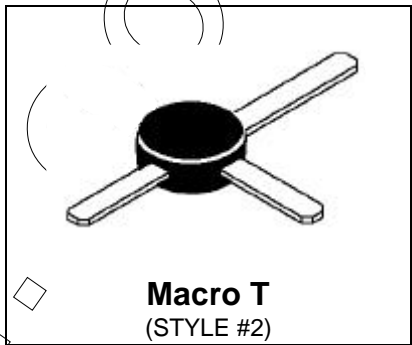

DESCRIPTION: Designed primarily for use in high-gain, low noise, small-signal amplifiers. Also used in applications requiring fast switching times.

ABSOLUTE MAXIMUM RATINGS ($T_{case} = 25^\circ\text{C}$)

Symbol	Parameter	Value	Unit
V_{CEO}	Collector-Emitter Voltage	15	Vdc
V_{CBO}	Collector-Base Voltage	20	Vdc
V_{EBO}	Emitter-Base Voltage	3.0	Vdc
I_C	Collector Current	30	mA

Thermal Data

P_D	Total Device Dissipation @ $T_A = 60^\circ\text{C}$	180	mWatts
	Derate above 60°C	2.0	mW/ $^\circ\text{C}$

ELECTRICAL SPECIFICATIONS (Tcase = 25°C)

STATIC
 (off)

Symbol	Test Conditions	Value			Unit
		Min.	Typ.	Max.	
BVCEO	Collector-Emitter Breakdown Voltage (IC = 1.0 mA _{dc} , IB = 0)	15	-	-	V _{dc}
BVCB0	Collector-Base Breakdown Voltage (IC = 0.1 mA _{dc} , IE = 0)	20	-	-	V _{dc}
BVEBO	Emitter-Base Breakdown Voltage (IE = 0.1 mA _{dc} , IC = 0)	3.0	-	-	V _{dc}
ICBO	Collector Cutoff Current (VCB = 10 V _{dc} , VBE = 0 V _{dc})	-	-	50	nA

(on)

HFE	DC Current Gain (IC = 14 mA _{dc} , VCE = 10 V _{dc})	25	-	250	-
-----	---	----	---	-----	---

DYNAMIC

Symbol	Test Conditions	Value			Unit
		Min.	Typ.	Max.	
F _{tau}	Current-Gain – Bandwidth Product (IC = 14 mA, VCE = 10 V _{dc} , f = 0.5 GHz)	-	5.0	-	GHz
CCB	Output Capacitance (VCB = 10 V _{dc} , IE = 0, f = 1.0 MHz)	-	0.5	1.0	pF

BFR90

FUNCTIONAL

Symbol	Test Conditions	Value			Unit
		Min.	Typ.	Max.	
NF	Noise Figure (IC = 2.0 mAdc, VCE = 10 Vdc, f = 0.5 GHz)	-	2.4	-	dB
	(IC = 2.0 mAdc, VCE = 10 Vdc, f = 1.0 GHz)	-	3.0	-	
GNF	Power Gain at Optimum Noise Figure (IC = 2.0 mAdc, VCE = 10 Vdc, f = 0.5 GHz)	-	15	-	dB
	(IC = 2.0 mAdc, VCE = 10 Vdc, f = 1.0 GHz)	-	10	-	
S ₂₁ ²	Insertion Gain (IC = 14 mAdc, VCE = 10 Vdc, f = 0.5 GHz)	15	16	-	dB
	(IC = 14 mAdc, VCE = 10 Vdc, f = 1.0 GHz)		11		
MSG	Maximum Stable Gain (IC = 14 mAdc, VCE = 10 Vdc, f = 0.5 GHz)	-	20	-	dB
	(IC = 14 mAdc, VCE = 10 Vdc, f = 1.0 GHz)		15		
G _{U max}	Maximum Unilateral Gain (1) (IC = 14 mAdc, VCE = 10 Vdc, f = 0.5 GHz)	-	18	-	dB
	(IC = 14 mAdc, VCE = 10 Vdc, f = 1.0 GHz)		12.5		

Table 1. Common Emitter S-Parameters, @ VCE = 10 V, IC = 14 mA

f (MHz)	S11		S21		S12		S22	
	S11	∠ φ	S21	∠ φ	S12	∠ φ	S22	∠ φ
100	0.382	-41	21.21	141	0.016	79	0.718	-9
200	0.282	-77	14.85	116	0.028	74	0.662	-18
300	0.217	-101	10.71	104	0.039	74	0.599	-20
500	0.162	-131	6.78	91	0.061	76	0.558	-24
700	0.140	-151	4.98	83	0.082	76	0.55	-28
800	0.135	-159	4.42	80	0.093	76	0.552	-29
1000	0.124	-176	3.59	74	0.117	75	0.553	-33

BFR90

RF Low Power PA, LNA, and General Purpose Discrete Selector Guide

Package	Device	Type	GPE Freq (MHz)	Pout (watts)	GPE (dB)	Efficiency (%)	GPE VCC	BVCEO	IC max (mA)
SO-8	MRF4427, R2	NPN	175	0.15	18	60	12	20	400
TO-39	2N4427	NPN	175	1	10	50	12	20	400
POWER MACRO	MRF553	NPN	175	1.5	11.5	60	12.5	16	500
POWER MACRO	MRF553T	NPN	175	1.5	11.5	50	12.5	16	500
TO-39	MRF607	NPN	175	1.75	11.5	50	12.5	16	330
TO-39	2N6255	NPN	175	3	7.8	50	12.5	18	1000
TO-72	2N5179	NPN	200		20		6	12	50
MACRO X	MRF559	NPN	512	0.5	10	65	7.5	16	150
MACRO X	MRF559	NPN	512	0.5	13	60	12.5	16	150
TO-39	2N3866A	NPN	400	1	10	45	28	30	400
SO-8	MRF3866, R1, R2	NPN	400	1	10	45	28	30	400
POWER MACRO	MRF555	NPN	470	1.5	11	50	12.5	16	400
POWER MACRO	MRF555T	NPN	470	1.5	11	50	12.5	16	400
MACRO X	MRF559	NPN	870	0.5	6.5	70	7.5	16	150
MACRO X	MRF559	NPN	870	0.5	9.5	65	12.5	16	150
SO-8	MRF8372, R1, R2	NPN	870	0.75	8	55	12.5	16	200
POWER MACRO	MRF557	NPN	870	1.5	8	55	12.5	16	400
POWER MACRO	MRF557T	NPN	870	1.5	8	55	12.5	16	400

Package	Device	Type	Freq (MHz)	NF (dB)	NF IC (mA)	NF VCE	GN (dB)	Gu Max (dB)	Ftau (MHz)	Ccb(pF)	BVCEO	IC max (mA)
TO-39	2N5109	NPN	200	3	10	15		12	1200	3.5	20	400
TO-39	MRF5943C	NPN	200	3.4	30	15		11.4	1000		30	400
SO-8	MRF5943, R1, R2	NPN	200	3.4	30	15		15	1300		30	400
TO-72	2N5179	NPN	200	4.5	1.5	6		17	900	1	12	50
TO-72	2N2857	NPN	300	5.5	50	6		13	1600	1	18	40
TO-79	MRF517	NPN	300	7.5	50	15		5.5	4600	3	25	150
TO-72	MRF907	NPN	450	1.5	5	6		11	4000	1	15	30
TO-72	2N6704	NPN	450	5	2	5		14	1400	1	15	50
MACRO T	BFR91	NPN	500	1.9	2	5	11	16.5	5000	1	12	35
MACRO T	BFR96	NPN	500	2	10	10		14.5	500	2.6	15	100
TO-8	MRF5812, R1, R2	NPN	500	2	50	10	15.5	17.8	5000		15	200
MACRO X	MRF581A	NPN	500	2	50	10	14	15	5000		15	200
Macro T	BFR90	NPN	500	2.4	2	10	15	18	5000	1	15	30
TO-72	BFR90	NPN	500	2.5	2	5		20	1300		15	50
TO-72	MRF914	NPN	500	2.5	5	10		15	4500		12	40
MACRO X	MRF581	NPN	500	2.5	50	10	15	17.8	5000		16	200
TO-39	MRF586	NPN	500	3	90	15	11	14.5	4500	2.2	17	200
MACRO X	MRF951	NPN	1000	1.3	5	6	14	17	8000	0.45	10	100
MACRO X	MRF571	NPN	1000	1.5	10	6	10		8000	1	10	70
MACRO T	BFR91	NPN	1000	2.5	2	5	8	11	5000	1	12	35
MACRO T	BFR90	NPN	1000	3	2	10	10	12.5	5000	1	15	30
TO-39	MRF545	PNP						14	1400	2	70	400
TO-39	MRF544	NPN						13.5	1500		70	400

RF (Low Power PA / General Purpose) Selection Guide

RF (LNA / General Purpose) Selection Guide

Low Cost RF Plastic Package Options

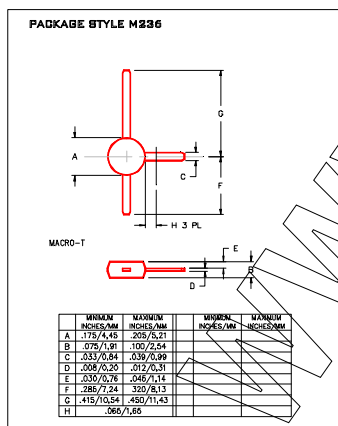

Macro T

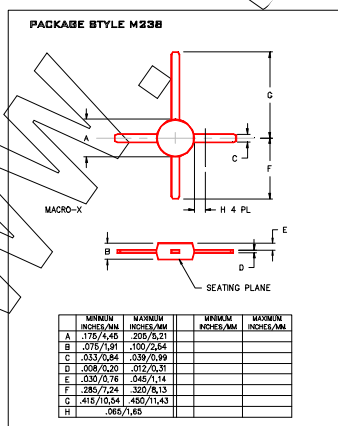

Macro X

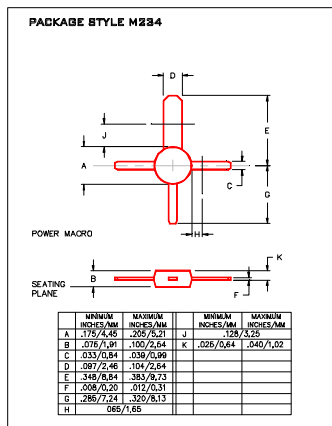

Power Macro

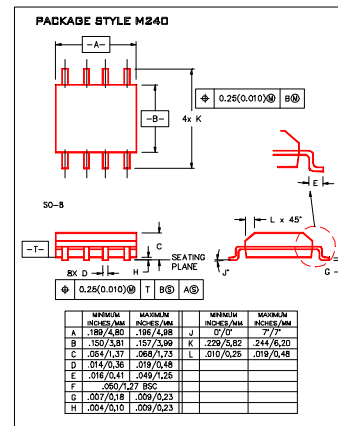

SO-8

BFR90

PACKAGE STYLE M236

PIN 1. COLLECTOR
 2. EMITTER
 3. BASE

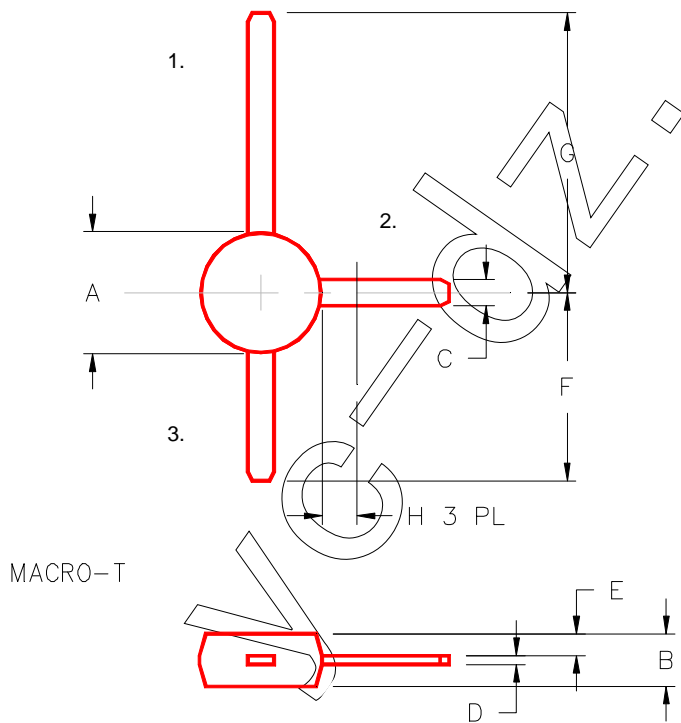

	MINIMUM INCHES/MM	MAXIMUM INCHES/MM	MINIMUM INCHES/MM	MAXIMUM INCHES/MM
A	.175/4,45	.205/5,21		
B	.075/1,91	.100/2,54		
C	.033/0,84	.039/0,99		
D	.008/0,20	.012/0,31		
E	.030/0,76	.045/1,14		
F	.285/7,24	.320/8,13		
G	.415/10,54	.450/11,43		
H	.065/1,65			