

THERMOPILE MODULE WITH INTEGRATED PROCESSING FOR TEMPERATURE MEASUREMENT

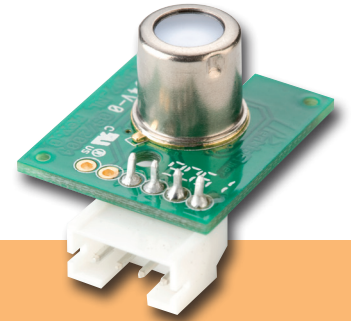

TPM 1T 0136 L5.5, TPM 1T 0134 M(y) – Thermopile Module (TPMI®)

Target Applications

- General purpose temperature monitoring

Features and Benefits

- Internal signal processing
- Factory calibrated
- Lens or mirror optics
- Ambient temperature compensation

Field of View

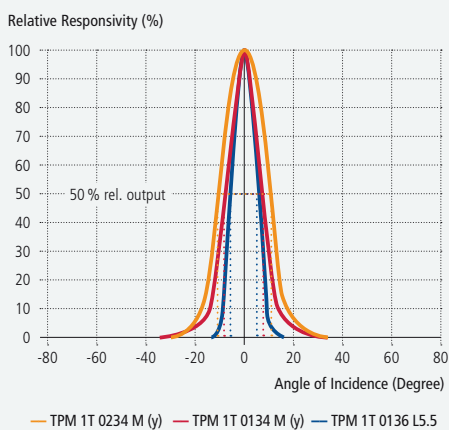

Filter



Product Description

The module range of Excelitas consists of a thermopile sensor mounted on a PCB with a connector. The PCB can also provide for optional features such as voltage regulation and a noise-reduction filter.

The module includes the integrated temperature compensation for a defined temperature environment and the calibration to a certain object temperature range. Modules cannot be programmed individually at the customer site. Thus, when ordering, the correct ambient and object temperature ranges need to be specified.

For requirements of defined spot sizes, we offer sensors with a field of view defined by optical apertures, internal lenses or external mirror optics. The mirror orientation M(y) can be specified and a protective external filter may be supplied with the module.

The module types are available with different versions of pcb P(x). For the external mirror version, we supply the mirror in different viewing orientations M(y); y = L (left) / y = F (front) / y = R (right). Customization: As the modules are always calibrated to target temperature range customized versions are available.

For the various object temperature ranges we offer the following pre-calibrated modules:

External mirror types

- -20...60°C: TPM 1T 0234 OAA060 P(x) M(y)
- -20...140°C: TPM 1T 0134 OAA140 P(x) M(y)
- -20...250°C: TPM 1T 0134 OAA250 P(x) M(y)
- -20...180°C: TPM 1T 0134 OAA180 P(x) M(y)

Integral lens types

- -20...60°C: TPM 1T 0236 L5.5 OAA060 P7
- -20...120°C: TPM 1T 0136 L5.5 OAA120 P7
- -20...180°C: TPM 1T 0136 L5.5 OAA180 P7
- -20...250°C: TPM 1T 0136 L5.5 OAA250 P7
- -20...300°C: TPM 1T 0136 L5.5 OAA300 P7

A temperature reference output is included. On request the modules can be supplied as an "OBA" version, which is calibrated but without internal temperature compensation. In this case the customer will do the temperature compensation externally with the use of the supplied reference output.

TPM 1T 0136 L5.5

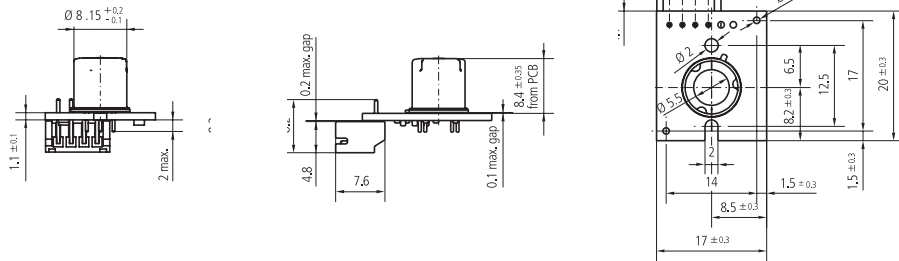
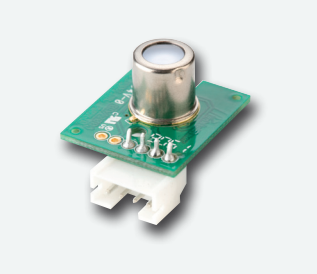

TPM 1T 0134 P6 M(y)

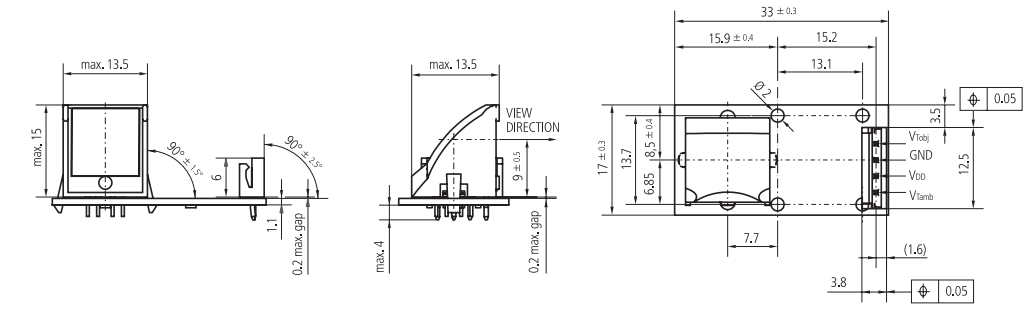
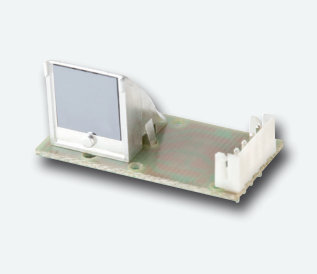

TPM 1T 0134 P9 M(y)

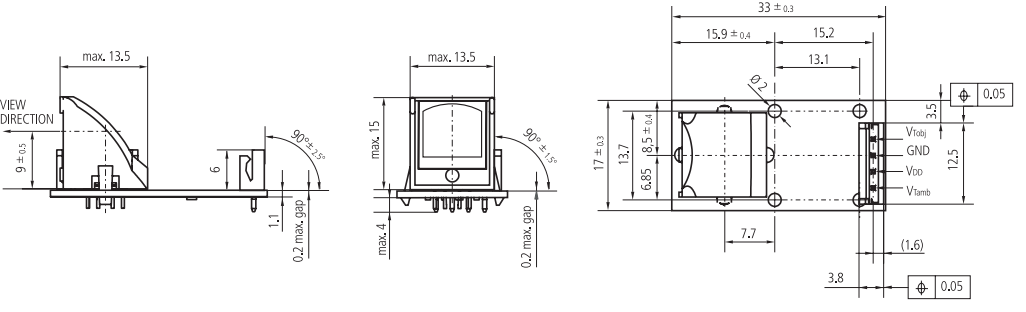
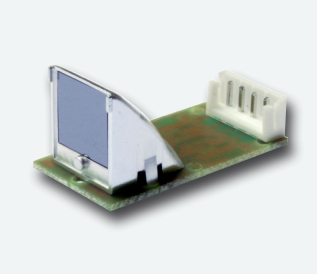

TPM 1T 0136 L5.5, TPM 1T 0134 M(y) – Thermopile Module (TPM)[®]

Parameter	Symbol	TPM 1T 0136 L5.5	TPM 1T 0134 P6 M(y)	TPM 1T 0134 P9 M(y)	Unit	Remark
Output voltage swing	V _O	0.25...(V _{DD} -0.25)	0.25...(V _{DD} -0.25)	0.25...(V _{DD} -0.25)	V	
Resistive output load	R _L	50	50	50	kΩ	min.
Object temp. accuracy		1.5	1.5	1.5	K	+/-
Response time	t _{resp}	100	100	100	ms	typ.
Field of view		4.5	5.5	5.5	°	TPiS 1T 01
Distance to spot size ratio		11:1	-	-		TPiS 1T 01
Field of view	FoV	7	7	7	°	TPiS 1T 02
Distance to spot size ratio		8:1	-	-		TPiS 1T 02
Supply voltage	V _{DD}	4.5... 5.5	4.5... 5.5	4.5... 15*	V	* = Voltage regulator
Supply current	I _{DD}	1.5	1.5	1.7	mA	typ. ; R _L > 1 MΩ
Operating temp. range		-25... +100	-25... +100	-25... +100	°C	
Storage temp. range		-40... +100	-40... +100	-40... +100	°C	
ESD tolerance		2.5	2.5	2.5	kV	Human body model