

Fast Low Profile (2.5 mm) Infrared Transceiver Module (MIR, 1.152 Mbit/s) for IrDA® Applications

Description

The TFDU5307 is an infrared transceiver module compliant to the latest IrDA physical layer standard, supporting IrDA speeds up to 1.152 Mbit/s (MIR) and carrier based remote control modes up to 2 MHz. Integrated within the transceiver module are a PIN photodiode, an infrared emitter (IRED), and a low-power control IC to provide a total front-end solution in a single package.

This Vishay MIR transceiver is built in a low profile package using the experiences of the lead frame babyface technology. The transceivers are capable of

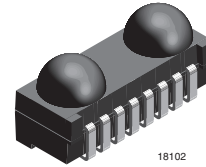

directly interfacing with a wide variety of I/O devices, which perform the modulation/ demodulation function. At a minimum, a V_{CC} bypass capacitor and a serial resistor for current control are the only external components required implementing a complete solution. TFDU5307 has a tri-state output and is floating in shutdown mode with a weak pull-up.

Features

- Compliant to the latest IrDA physical layer specification (up to 1.152 Mbit/s) and TV Remote Control, bi-directional operation included.
- Sensitivity covers full IrDA range. Recommended operating range is from nose to nose to 70 cm
- Operates from 2.7 V to 5.5 V within specification
- Low power consumption (typ. 0.55 mA Supply current in receive mode, no signal)
- Power shutdown mode ($< 5 \mu\text{A}$ Shutdown Current in Full Temperature Range, up to 85 °C)
- Surface mount package, low profile universal (L 8.5 mm x W 2.9 mm x H 2.5 mm) Capable of surface mount soldering to Side and top view orientation
- Backward pin compatible to Vishay Semiconductors SIR and MIR infrared transceivers
- High efficiency emitter
- Directly interfaces with various super I/O and controller devices
- Tri-state receiver output, floating in shut down with a weak pull-up
- Split power supply, transmitter and receiver can be operated from two power supplies with relaxed requirements saving costs, US Patent No. 6,157,476
- Logic voltage 1.5 V to 5.5 V is independent of IRED driver and analog supply voltage
- Only one external component required
- TV remote control supported
- Transmitter intensity can be adjusted by an external resistor for extended range (> 0.7 m) or minimum low power (> 0.2 m) IrDA compliance.
- Lead(Pb)-free device
- Device in accordance to RoHS 2002/95/EC and WEEE 2002/96EC

Applications

- Telecommunication products (cellular phones, pagers)
- Digital still and video cameras
- Printers, fax machines, photocopiers, screen projectors
- Low power consumption (typ. 0.55 mA Supply current in receive mode, no signal)
- Medical and industrial data collection
- Notebook computers, desktop PCs, Palmtop Computers (Win CE, Palm PC), PDAs
- Internet TV boxes, video conferencing systems
- External infrared adapters (dongles)
- Kiosks, POS, Point and Pay devices including IrFM - applications

Parts Table

Part	Description	Qty / Reel
TFDU5307-TR1	Oriented in carrier tape for side view surface mounting	750 pcs
TFDU5307-TR3	Oriented in carrier tape for side view surface mounting	2500 pcs
TFDU5307-TT1	Oriented in carrier tape for top view surface mounting	750 pcs
TFDU5307-TT3	Oriented in carrier tape for top view surface mounting	2500 pcs

Functional Block Diagram

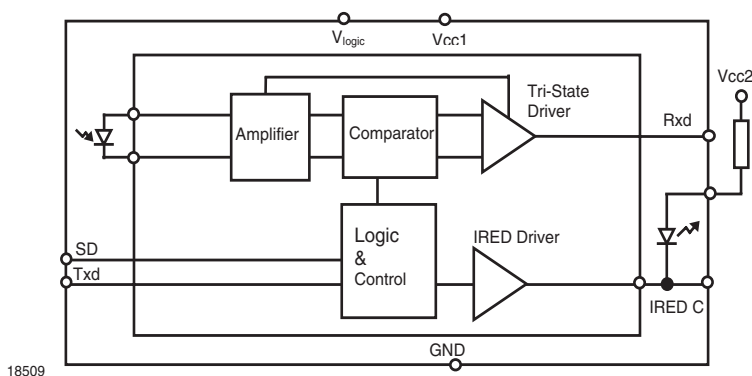

Pin Description

Pin Number	Function	Description	I/O	Active
1	IRED Anode	Connect IRED anode to the V_{CC2} power supply through an external current limiting resistor. A separate unregulated power supply can be used at this pin.		
2	IRED Cathode	IRED Cathode, internally connected to the driver transistor		
3	Txd	This Schmitt-Trigger input is used to transmit serial data when SD is low. An on-chip protection circuit disables the LED driver if the Txd pin is asserted for longer than 80 μ s. When used in conjunction with the SD pin, this pin is also used to control receiver output pulse duration. The input threshold voltage adapts to and follows the logic voltage reference applied to the V_{logic} pin (pin 7).	I	HIGH
4	Rxd	Received Data Output, push-pull CMOS driver output capable of driving standard CMOS or TTL loads. No external pull-up or pull-down resistor is required. Floating with a weak pull-up of 500 k Ω (typ.) in shutdown mode. The voltage swing is defined by the applied V_{logic} voltage	O	LOW
5	SD	Shutdown. Also used for setting the output pulse duration. Setting this pin active for more than 1.5 ms places the module into shutdown mode. Before that ($t < 0.7$ ms) on the falling edge of this signal, the state of the Txd pin is sampled and used to set the receiver output to long pulse duration (2 μ s) or to short pulse duration (0.4 μ s) mode. The input threshold voltage adapts to and follows the logic voltage reference applied to the V_{logic} pin (pin 7).	I	HIGH
6	V_{CC1}	Supply Voltage		
7	V_{logic}	V_{logic} defines the logic voltage levels for input and output. The Rxd output range is from 0 V to V_{logic} ; for optimum noise suppression the inputs' logic decision level is $0.5 \times V_{logic}$	I	
8	GND	Ground		

Pinout

TFDU5307
weight 75 mg

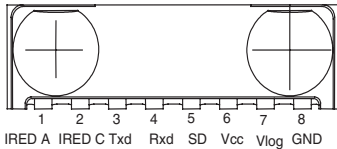

Definitions:

In the Vishay transceiver data sheets the following nomenclature is used for defining the IrDA operating modes:

SIR: 2.4 kbit/s to 115.2 kbit/s, equivalent to the basic serial infrared standard with the physical layer version IrPhy 1.0

MIR: 576 kbit/s to 1152 kbit/s

FIR: 4 Mbit/s

VFIR: 16 Mbit/s

MIR and FIR were implemented with IrPhy 1.1, followed by IrPhy 1.2, adding the SIR Low Power Standard. IrPhy 1.3 extended the Low Power Option to MIR and FIR and VFIR was added with IrPhy 1.4. A new version of the standard in any case obsoletes the former version.

With introducing the updated versions the old versions are obsolete. Therefore the only valid IrDA standard is the actual version IrPhy 1.4 (in Oct. 2002).

Absolute Maximum Ratings

Reference point Ground (pin 8) unless otherwise noted.

Typical values are for DESIGN AID ONLY, not guaranteed nor subject to production testing.

Parameter	Test Conditions	Symbol	Min	Typ.	Max	Unit
Supply voltage range, transceiver	- 0.3 V < V _{CC2} < 6 V - 0.5 V < V _{logic} < 5.5 V	V _{CC1}	- 0.3		+ 6.0	V
Supply voltage range, transmitter	- 0.5 V < V _{CC1} < 6 V - 0.5 V < V _{logic} < 5.5 V	V _{CC2}	- 0.3		+ 6.5	V
Supply voltage range, V _{logic}	- 0.5 V < V _{CC1} < 6 V - 0.3 V < V _{CC2} < 6.5 V	V _{logic}	- 0.3		+ 5.5	V
Input current	for all pins, except IRED anode pin				10	mA
Output sinking current					25	mA
Power dissipation	see derating curve, figure 4	P _D			500	mW
Junction temperature		T _J			125	°C
Ambient temperature range (operating)		T _{amb}	- 25		+ 85	°C
Storage temperature range		T _{stg}	- 25		+ 85	°C
Soldering temperature	see recommended solder profile (figure 3)				240	°C
Average output current, pin 1		I _{IRED(DC)}			125	mA
Repetitive pulsed output current, pin 1 to pin 2	t _r < 90 μs, t _{on} < 20 %	I _{IRED(RP)}			600	mA
IRED anode voltage, pin 1		V _{IREDA}	- 0.5		+ 6.5	V
Voltage at all inputs and outputs	V _{in} < V _{CC1} is allowed	V _{in}	- 0.5		+ 5.5	V
Load at mode pin when used as mode indicator					50	pF

Eye safety information

Parameter	Test Conditions	Symbol	Min	Typ.	Max	Unit
Virtual source size	Method: (1-1/e) encircled energy	d	1.8	2.0		mm
Maximum intensity for class 1	IEC60825-1 or EN60825-1, edition Jan. 2001, operating below the absolute maximum ratings	I_e			*) (500)**)	mW/sr

*) Due to the internal limitation measures the device is a "class 1" device.

***) IrDA specifies the max. intensity with 500 mW/sr.

Electrical Characteristics

Transceiver

$T_{amb} = 25\text{ }^{\circ}\text{C}$, $V_{CC1} = V_{CC2} = 2.7\text{ V}$ to 5.5 V unless otherwise noted.

Typical values are for DESIGN AID ONLY, not guaranteed nor subject to production testing.

Parameter	Test Conditions	Symbol	Min	Typ.	Max	Unit
Supply voltage		V_{CC1}	2.7		5.5	V
Idle supply current	SD = Low, $E_e = 1\text{ klx}$	I_{CC1}		550	900	μA
Average dynamic supply current, transmitting	$I_{IRED} = 500\text{ mA}$, 25 % Duty Cycle	I_{CC}		1100	1500	μA
Shutdown supply current	SD = High, $T = 25\text{ }^{\circ}\text{C}$, $E_e = 0\text{ klx}$	I_{SD}			1	μA
	SD = High, $T = 25\text{ }^{\circ}\text{C}$, $E_e = 1\text{ klx}$ *)	I_{SP}			2.5	μA
Standby supply current	SD = High, $T = 85\text{ }^{\circ}\text{C}$, not ambient light sensitive	I_{SD}			5	μA
Operating temperature range		T_A	- 25		+ 85	$^{\circ}\text{C}$
Output voltage low, Rxd	$C_{Load} = 15\text{ pF}$, $I_{OL} = 1\text{ mA}$	V_{OL}			0.4	V
Output voltage high, Rxd	$I_{OH} = - 500\text{ }\mu\text{A}$	V_{OH}	$0.8 \times V_{logic}$			V
	$I_{OH} = - 250\text{ }\mu\text{A}$, $C_{Load} = 15\text{ pF}$	V_{OH}	$0.9 \times V_{logic}$			V
Rxd to V_{CC1} impedance		R_{Rxd}	400	500	600	$\text{k}\Omega$
Input voltage low (Txd, SD)		V_{IL}	- 0.5		0.5	V
Input voltage high (Txd, SD)	CMOS level**)	V_{IH}	$V_{logic} - 0.5$		$V_{logic} + 0.5$	V
Input leakage current (Txd, SD)	$V_{in} = 0.9 \times V_{logic}$	I_{ICH}	- 2		+ 2	μA
Controlled pull down current	SD, Txd = "0" to "1", $0 < V_{in} < 0.15 V_{logic}$	I_{IRTx}			+ 150	μA
	SD, Txd = "0" to "1", $V_{in} > 0.7 V_{logic}$	I_{IRTx}	- 1	0	1	μA
Input capacitance (Txd, SD)		C_{IN}			5	pF

*) Standard illuminant A

***) The typical threshold level is $0.5 \times V_{logic}$. It is recommended to use the specified min/max values to avoid increased operating current. The inputs in low state are actively loaded for noise protection. See for that the "Controlled pull down current" spec. Equivalently a pull up current stabilizes the state when the inputs are in high state.

Optoelectronic Characteristics
Receiver
 $T_{amb} = 25\text{ }^{\circ}\text{C}$, $V_{CC} = 2.7\text{ V}$ to 5.5 V unless otherwise noted.

Typical values are for DESIGN AID ONLY, not guaranteed nor subject to production testing.

Parameter	Test Conditions	Symbol	Min	Typ.	Max	Unit
Minimum detection threshold irradiance	9.6 kbit/s to 1.152 Mbit/s $\lambda = 850\text{ nm} - 900\text{ nm}$	E_e		40 (4)	90 (9)	mW/m^2 ($\mu\text{W}/\text{cm}^2$)
Maximum detection threshold irradiance	$\lambda = 850\text{ nm} - 900\text{ nm}$	E_e		5 (500)		kW/m^2 (mW/cm^2)
No detection receiver input irradiance	Threshold! No Rxd output below this irradiance value allowed	E_e	4 (0.4)			mW/m^2 ($\mu\text{W}/\text{cm}^2$)
Rise time of output signal	10 % to 90 %, $C_L = 15\text{ pF}$, $V_{logic} = V_{CC}$	$t_{r(Rxd)}$	20		60	ns
Fall time of output signal	90 % to 10 %, $C_L = 15\text{ pF}$, $V_{logic} = V_{CC}$	$t_{f(Rxd)}$	20		60	ns
Rxd pulse width of output signal, default mode after power on or reset	input pulse length $P_{Wopt} > 200\text{ ns}$	t_{PW}	300	400	500	ns
SIR ENDEC compatibility mode ^{*)} : Rxd pulse width of output signal	input pulse length $P_{Wopt} > 200\text{ ns}$, see chapter "Programming"	t_{PW}	1.7	2.0	2.9	μs
Stochastic jitter, leading edge	input irradiance = $100\text{ mW}/\text{m}^2$, 1.152 Mbit/s, 576 kbit/s				80	ns
	input irradiance = $100\text{ mW}/\text{m}^2$, $\leq 115.2\text{ kbit/s}$				350	ns
Standby /Shutdown delay	after shutdown active or (SD low to high transition)		0.6		1.5	ms
Shutdown active time window for programming	During this time the pulse duration of the output can be programmed to the application mode. see chapter "Programming"				600	μs
Receiver start up time power on delay shutdown recovery delay	after shutdown inactive (SD high to low transition) and after power-on				300	μs
Latency		t_L			200	μs

^{*)} Some ENDECs are not able to decode short pulses as valid SIR pulses. Therefore this additional mode was added in TFDU5307. TFDU5307 is set to the "short output pulse" as default after power on, also after recovering from the shutdown mode (SD must have been longer active than 1.5 ms). For mode changing see the chapter "Programming"

Transmitter

$T_{amb} = 25\text{ }^{\circ}\text{C}$, $V_{CC} = 2.7\text{ V}$ to 5.5 V unless otherwise noted.

Typical values are for DESIGN AID ONLY, not guaranteed nor subject to production testing.

Parameter	Test Conditions	Symbol	Min	Typ.	Max	Unit
IRED operating current, recommended serial resistor for MIR applications	$V_{CC2} = 3.3\text{ V}$: $R_S = 2.0\text{ }\Omega$ $V_{CC2} = 5.0\text{ V}$: $R_S = 5.6\text{ }\Omega$	I_D		450	500	mA
Output leakage IRED current	$T_{xd} = 0\text{ V}$, $0 < V_{CC1} < 5.5\text{ V}$	I_{IRED}	- 1		1	μA
Output radiant intensity recommended application circuit, see figure 1	$\alpha = 0\text{ }^{\circ}$, $I_f = 420\text{ mA}$ $T_{xd} = \text{High}$, $SD = \text{Low}$ **)	I_e	110		500	mW/sr
	$\alpha = 0\text{ }^{\circ}$, 15 ° , $I_f = 420\text{ mA}$ $T_{xd} = \text{High}$, $SD = \text{Low}$ **)	I_e	70	120	500	mW/sr
Output radiant intensity	$V_{CC1} = 5.0\text{ V}$, $\alpha = 0\text{ }^{\circ}$, 15 ° $T_{xd} = \text{Low}$ or $SD = \text{High}$ (Receiver is inactive as long as $SD = \text{High}$)	I_e			0.04	mW/sr
Output radiant intensity, angle of half intensity		α		± 24		$^{\circ}$
Peak - emission wavelength ^{*)}		λ_p	880		900	nm
Spectral bandwidth		$\Delta\lambda$		45		nm
Optical rise time, fall time		t_{ropt} , t_{fopt}	6		40	ns
Optical output pulse duration	input pulse width 217 ns, 1.152 Mbit/s Note: IrDA specification for MIR	t_{opt}	190 (147.6)	217	240 (260)	ns ns
	input pulse width $t_{Txd} < 80\text{ }\mu\text{s}$	t_{opt}	20		t_{Txd}	μs
	input pulse width $t_{Txd} \geq 80\text{ }\mu\text{s}$	t_{opt}	20		85	μs
Optical overshoot					25	%

^{*)} Note: Due to this wavelength restriction compared to the IrDA spec of 850 nm to 900 nm the transmitter is able to operate as source for the standard Remote Control applications with codes as e.g. Philips RC5/RC6[®] or RECS 80. When operated under IrDA full range conditions (>120 mW/sr) the RC range to be covered is in the range from 8 m to 12 m, provided that state of the art remote control receivers are used.

^{**) Typ. conditions for $I_f = 420\text{ mA}$, $V_{CC2} = 3.3\text{ V}$, $R_S = 2.3\text{ }\Omega$, $V_{CC2} = 5.0\text{ V}$, $R_S = 6.4\text{ }\Omega$}

Recommended Circuit Diagram

Used with a clean low impedance power supply the TFDU5307 only needs an external series current limiting resistor. However, depending on the entire system design and board layout, additional components may be required (see figure 1).

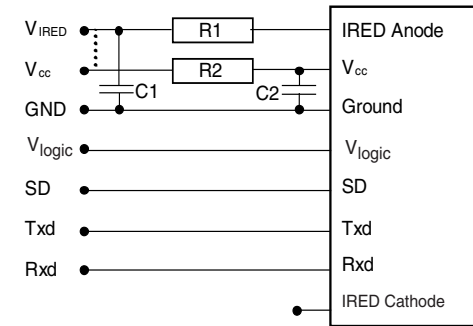

18147

Figure 1. Recommended Application Circuit

The capacitor C1 is buffering the supply voltage and eliminates the inductance of the power supply line. This one should be a Tantalum or other fast capacitor to guarantee the fast rise time of the IRED current. The resistor R1 is the current limiting resistor and this is supply voltage dependent, see derating curve in figure 4, to avoid too high internal power dissipation. Vishay's transceivers integrate a sensitive receiver and a built-in power driver. The combination of both needs a careful circuit board layout. The use of thin, long, resistive and inductive wiring should be avoided.

The inputs (Txd, SD) and the output Rxd should be directly (DC) coupled to the I/O circuit.

The capacitor C2 combined with the resistor R2 is the low pass filter for smoothing the supply voltage.

R2, C1 and C2 are optional and dependent on the quality of the supply voltages and injected noise. An unstable power supply with dropping voltage during transmission may reduce the sensitivity (and transmission range) of the transceiver.

The placement of these parts is critical. It is strongly recommended to position C2 as close as possible to the transceiver power supply pins. A Tantalum capacitor should be used for C1 while a ceramic capacitor is used for C2.

In addition, when connecting the described circuit to the power supply, low impedance wiring should be used.

When extended wiring is used the inductance of the power supply can cause dynamically a voltage drop at V_{CC2} . Often some power supplies are not apply to follow the fast current rise time. In that case another $4.7 \mu\text{F}$ (type, see table under C1) at V_{CC2} will be helpful.

Under extreme EMI conditions as placing an RF-transmitter antenna on top of the transceiver, we recommend to protect all inputs by a low-pass filter, as a minimum a 12 pF capacitor, especially at the Rxd port.

Keep in mind that basic RF - design rules for circuit design should be taken into account. Especially longer signal lines should not be used without termination. See e.g. "The Art of Electronics" Paul Horowitz, Winfield Hill, 1989, Cambridge University Press, ISBN: 0521370957.

Table 1.
Recommended Application Circuit Components

Component	Recommended Value	Vishay Part Number
C1	4.7 μF , 16 V, Tantalum	293D 475X9 016B
C2	0.1 μF , Ceramic	VJ 1206 Y 104 J XXMT
R1	5 V supply voltage: 5.6 Ω s. text 0.25 W (recommended using two 2.8 Ω , 0.125 W resistors in series). 3.3 V supply voltage: 2.0 Ω s. text 0.25 W	e.g. 2 x CRCW-1206-2R0-F-RT1 for 3.3 V supply voltage
R2	47 Ω , 0.125 W	CRCW-1206-47R0-F-RT1

I/O and Software

In the description, already different I/Os are mentioned. Different combinations are tested and the function verified with the special drivers available from the I/O suppliers. In special cases refer to the I/O manual, the Vishay application notes, or contact directly Vishay Sales, Marketing or Application.

Programming

Pulse duration Switching

After Power-on the TFDU5307 is in the default short Rxd pulse duration mode.

Some ENDECs are not able to decode short pulses as valid SIR pulses. Therefore an additional mode with extended pulse duration (same as in standard SIR transceivers) is added in TFDU5307. TFDU5307 is set to the "short output pulse" as default after power on, and after recovering from the shutdown mode (SD being active longer than 1.5 ms).

To switch the transceivers from the short Rxd pulse duration mode to the long pulse duration mode and vice versa, follow the procedure described below.

Setting to the ENDEC compatibility mode with an Rxd pulse duration of 2 μs

1. Set SD input to logic "HIGH".
2. Set Txd input to logic "HIGH". Wait $t_s \geq 200$ ns.
3. Set SD to logic "LOW" (this negative edge latches state of Txd, which determines speed setting).
4. After waiting $t_h \geq 200$ ns.

After that Txd is enabled as normal Txd input and the Rxd output is set for the longer Rxd - pulse duration mode.

Setting back to the default mode with a 400 ns pulse duration

1. Set SD input to logic "HIGH".
2. Set Txd input to logic "LOW". Wait $t_s \geq 200$ ns.

3. Set SD to logic "LOW" (this negative edge latches state of Txd, which determines speed setting).
4. After waiting $t_h \geq 200$ ns Txd can be set to logic "LOW". The hold time of Txd is limited by the maximum allowed pulse length.

After that Txd is now enabled as normal Txd input and the Rxd output is set for the short Rxd - pulse duration mode.

The timing of the pulse duration changing procedure is quite uncritical. However, the whole change must not take more than 600 μs. See in the spec. "Shutdown Active Time Window for Programming"

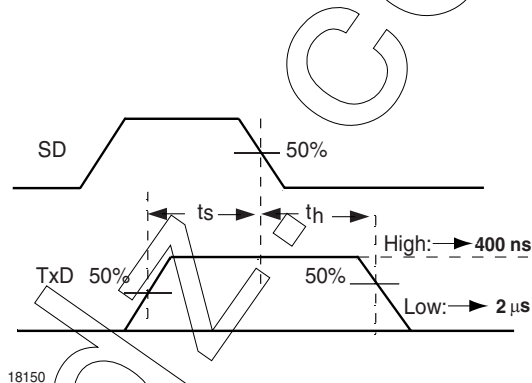

Figure 2. Timing Diagram for changing the output pulse duration

Simplified Method

Setting the device to the long pulse duration is simply applying a short active (less than 600 μs) pulse to SD. In any case a short SD pulse will force the device to leave the default mode and go the compatibility mode. Vice versa applying a 1.5 ms (minimum) pulse at SD will cause the device to go back to the default mode by activating a power-on-reset and setting the device to the default short pulse mode. This simplified method takes more time but may be easier to handle.

Table 2.
Truth table

Inputs		Outputs		Remark	
SD	Txd	Optical input Irradiance mW/m ²	Rxd	Transmitter	Operation
high	x	x	weakly pulled (500 kΩ) to V _{CC1}	0	Time window for pulse duration setting
high	x	x	weakly pulled (500 kΩ) to V _{CC1}	0	Shutdown
low	high	x	low (active)	I _e	Transmitting
	high	x	high inactive	0	Protection is active
	low	< 4	high inactive	0	Ignoring low signals below the IrDA defined threshold for noise immunity
	low	> Minimum irradiance E _e < Maximum irradiance E _e	low (active)	0	Response to an IrDA compliant optical input signal
	low	> Maximum irradiance E _e	undefined	0	Overload conditions can cause unexpected outputs

Recommended Solder Profiles for TFDU5307

Solder Profile for Sn/Pb soldering

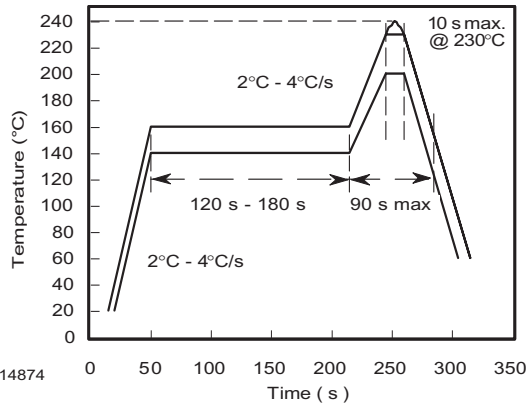

Figure 3. Recommended Solder Profile for Sn/Pb soldering

Lead-Free, Recommended Solder Profile

The TFDU5307 is a lead-free transceiver and qualified for lead-free processing. For lead-free solder paste like $\text{Sn}_{(3.0 - 4.0)}\text{Ag}_{(0.5 - 0.9)}\text{Cu}$, there are two standard reflow profiles: Ramp-Soak-Spike (RSS) and Ramp-To-Spike (RTS). The Ramp-Soak-Spike profile was developed primarily for reflow ovens heated by infrared radiation. With widespread use of forced convection reflow ovens the Ramp-To-Spike profile is used increasingly. Shown below in figure 4 is Vishay's recommended profile for use with the TFDU5307 transceivers. For more details please refer to Application note: [SMD Assembly Instruction](#).

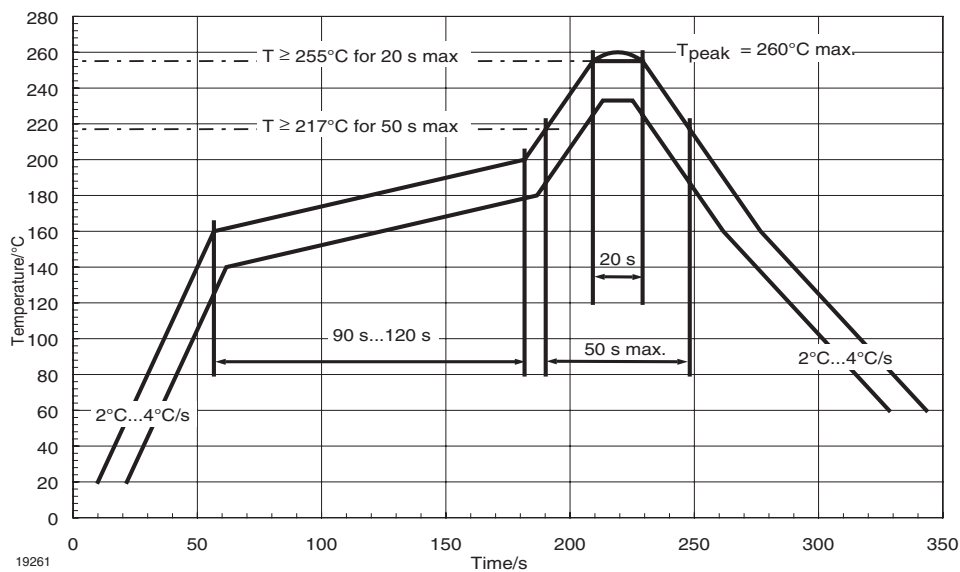

Figure 4. Solder Profile, RSS Recommendation

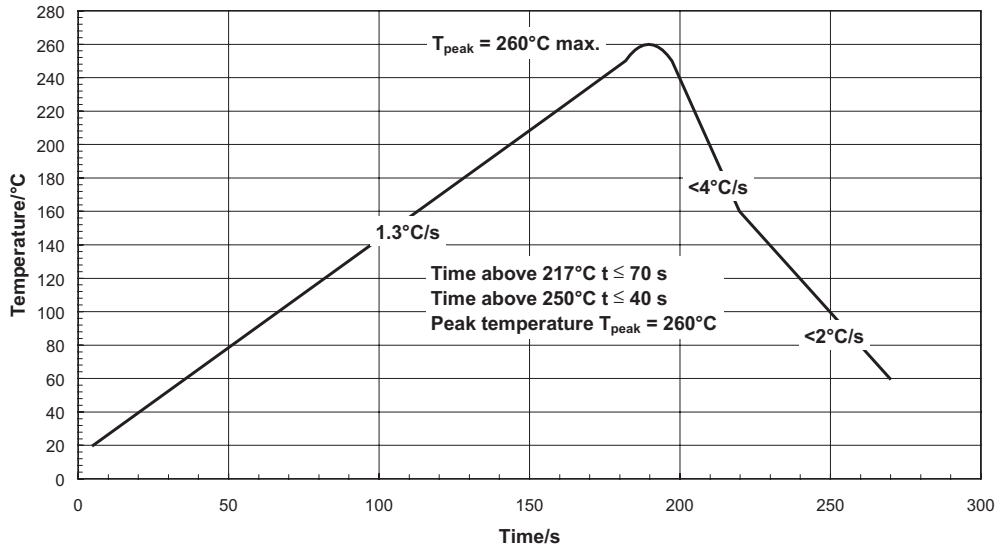

Figure 5. Solder Profile, RTS Recommendation

A ramp-up rate less than 0.9°C/s is not recommended. Ramp-up rates faster than 1.3°C/s damage an optical part because the thermal conductivity is less than compared to a standard IC.

Current Derating Diagram

Figure 6 shows the maximum operating temperature when the device is operated without external current limiting resistor. A power dissipating resistor of 2 Ω is recommended from the cathode of the IRED to Ground for supply voltages above 4 V. In that case the device can be operated up to 85 °C, too.

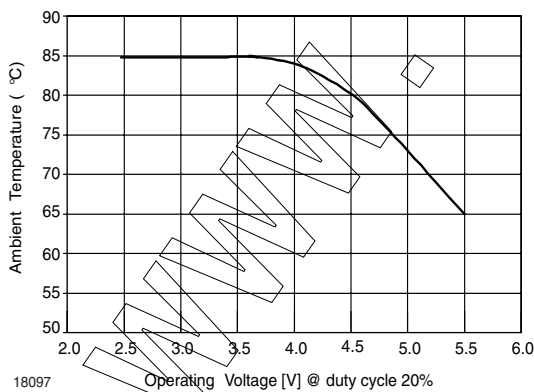
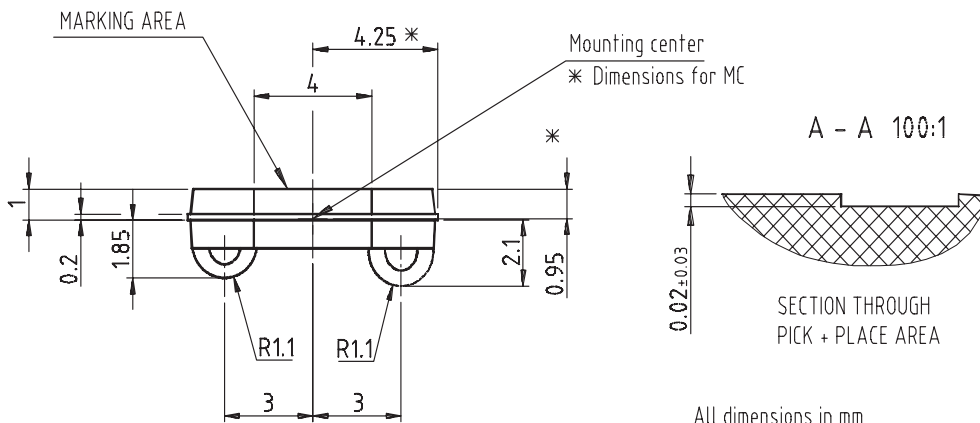
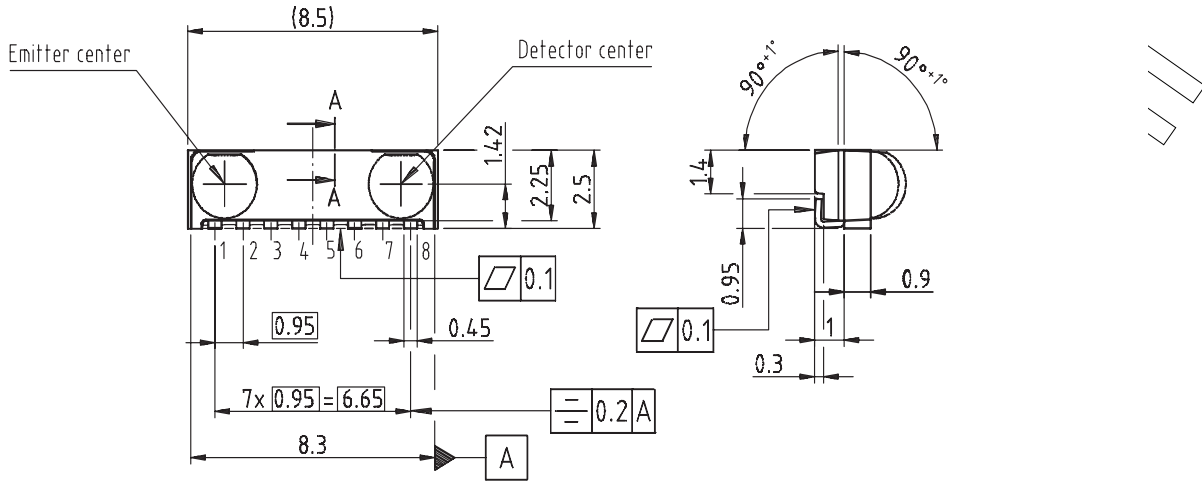

Figure 6. Temperature Derating Diagram

TFDU5307 - TinyFace (Universal) Package (Dimensions in mm)

(Mechanical Dimensions)



All dimensions in mm

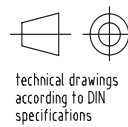

Drawing-No.: 6.550-5252.01-4
Issue: 1; 17.01.03

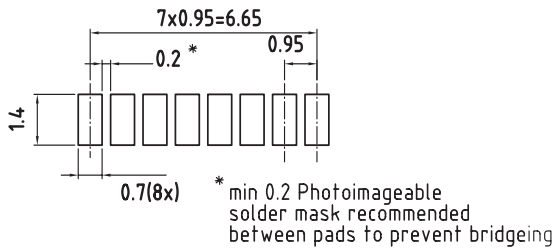

18100

Reel Dimensions

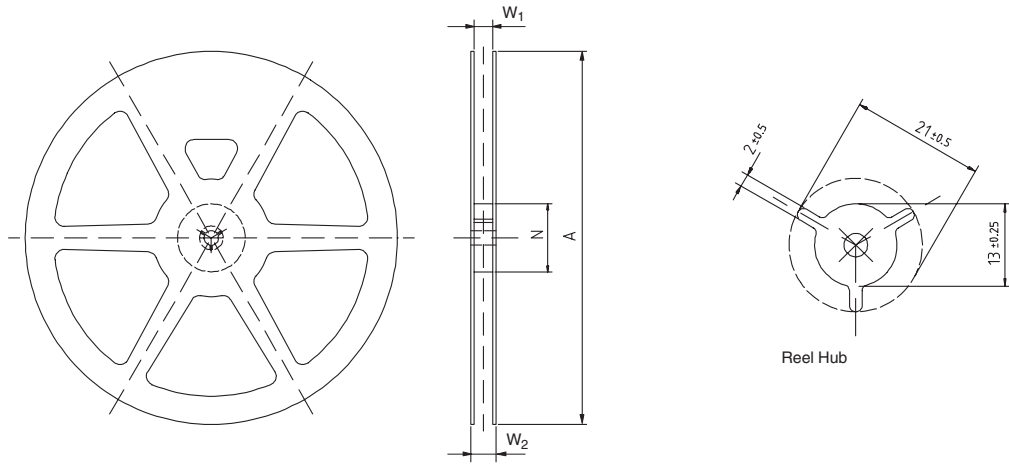

14017

Tape Width	A max.	N	W_1 min.	W_2 max.	W_3 min.	W_3 max.
mm	mm	mm	mm	mm	mm	mm
16	330	50	16.4	22.4	15.9	19.4

www.vishay.com

Tape Dimensions in mm

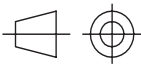
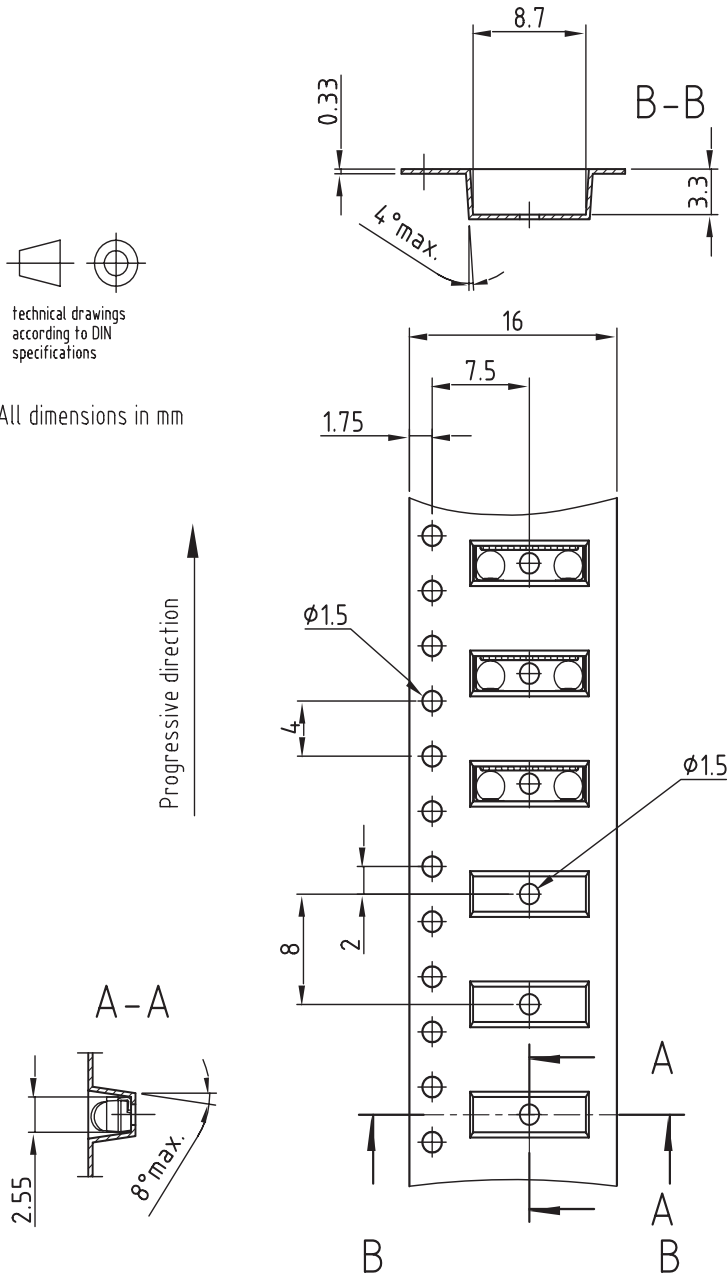

technical drawings
according to DIN
specifications

All dimensions in mm

Progressive direction

Drawing-No.: 9.700-5280.01-4

Issue: 1; 03.11.03

18306

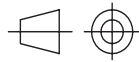

Technical drawings
according to DIN
specifications

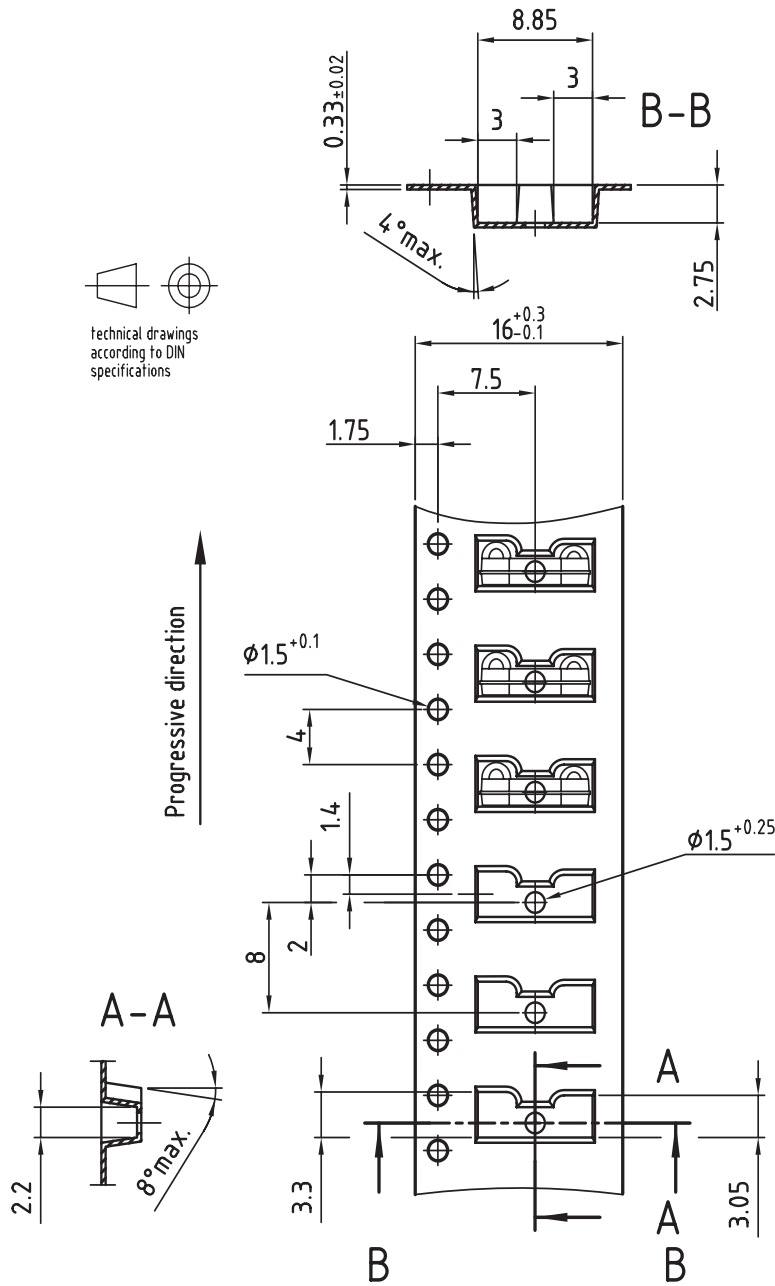

18307

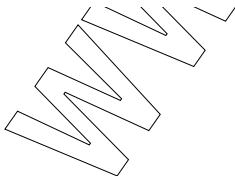

Ozone Depleting Substances Policy Statement

It is the policy of Vishay Semiconductor GmbH to

1. Meet all present and future national and international statutory requirements.
2. Regularly and continuously improve the performance of our products, processes, distribution and operating systems with respect to their impact on the health and safety of our employees and the public, as well as their impact on the environment.

It is particular concern to control or eliminate releases of those substances into the atmosphere which are known as ozone depleting substances (ODSs).

The Montreal Protocol (1987) and its London Amendments (1990) intend to severely restrict the use of ODSs and forbid their use within the next ten years. Various national and international initiatives are pressing for an earlier ban on these substances.

Vishay Semiconductor GmbH has been able to use its policy of continuous improvements to eliminate the use of ODSs listed in the following documents.

1. Annex A, B and list of transitional substances of the Montreal Protocol and the London Amendments respectively
2. Class I and II ozone depleting substances in the Clean Air Act Amendments of 1990 by the Environmental Protection Agency (EPA) in the USA
3. Council Decision 88/540/EEC and 91/690/EEC Annex A, B and C (transitional substances) respectively.

Vishay Semiconductor GmbH can certify that our semiconductors are not manufactured with ozone depleting substances and do not contain such substances.

We reserve the right to make changes to improve technical design and may do so without further notice.

Parameters can vary in different applications. All operating parameters must be validated for each customer application by the customer. Should the buyer use Vishay Semiconductors products for any unintended or unauthorized application, the buyer shall indemnify Vishay Semiconductors against all claims, costs, damages, and expenses, arising out of, directly or indirectly, any claim of personal damage, injury or death associated with such unintended or unauthorized use.

Vishay Semiconductor GmbH, P.O.B. 3535, D-74025 Heilbronn, Germany
Telephone: 49 (0)7131 67 2831, Fax number: 49 (0)7131 67 2423