

Infrared Transceiver 9.6 kbit/s to 115.2 kbit/s (SIR)

Description

The TFBS4652 is one of the smallest IrDA compliant transceivers available. It supports data rates up to 115 kbit/s. The transceiver consists of a PIN photodiode, infrared emitter, and control IC in a single package.



Features

- Compliant with the IrDA® physical layer IrPHY 1.4 (low power specification, 9.6 kbit/s to 115.2 kbit/s)
- Link distance: 30 cm/20 cm full 15° cone with standard or low power IrDA, respectively. Emission intensity can be set by an external resistor to increase the range to > 50 cm
- Typical transmission distance to standard device: 50 cm
- Small package - L 6.8 mm x W 2.8 mm x 1.6 mm
- Low current consumption 75 μ A idle @ 3.6 V
- Operates from 2.4 V to 3.6 V within specification over full temperature range from - 25 °C to + 85 °C
- Lead (Pb)-free device
- Device in accordance to RoHS 2002/95/EC and WEEE 2002/96/EC
- Split power supply, emitter can be driven by a separate power supply not loading the regulated U.S. Pat. No. 6,157,476
- Adjustable to logic I/O voltage swing from 1.5 V to 5.5 V

Applications

- Mobile phone
- PDAs

Parts Table

Part	Description	Qty / Reel
TFBS4652-TR1	Oriented in carrier tape for side view surface mounting	1000 pcs
TFBS4652-TR3	Oriented in carrier tape for side view surface mounting	2500 pcs

Functional Block Diagram

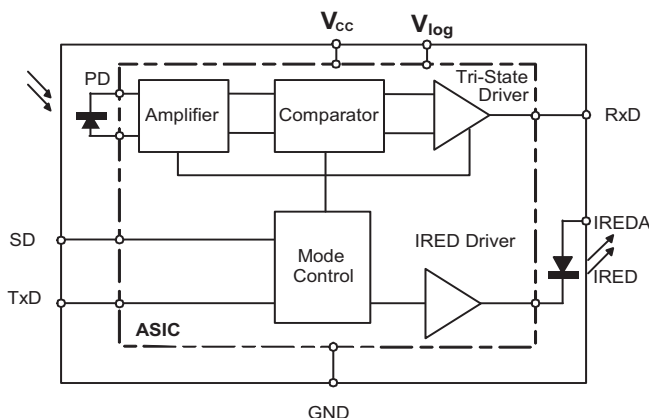

19288

Pin Description

Pin Number	Function	Description	I/O	Active
1	IREDA	IRED Anode, connected via a current limiting resistor to V_{cc2} . A separate unregulated power supply can be used.		
2	RXD	Receiver Output. Normally high, goes low for the duration of the receive pulse. Output is a CMOS tri-state driver, which swings between ground and V_{logic} . Receiver echoes transmitter output.	O	LOW
3	TXD	Transmitter Data Input. Setting this input above the threshold turns on the transmitter. This input switches the IRED with the maximum transmit pulse width of about 50 μ s.	I	HIGH
4	SD	Shut Down. Logic Low at this input enables the receiver, enables the transmitter, and un-tri-states the receiver output. It must be driven high for shutting down the transceiver.	I	HIGH
5	V_{logic}	Reference for the logic swing of the output and the input logic levels.	I	
6	V_{CC}	Power Supply, 2.4 V to 3.6 V. This pin provides power for the receiver and transmitter drive section. Connect V_{cc1} via an optional filter.		
7	GND	Ground		

Pinout

TFBS4652, bottom view
weight 0.05 g

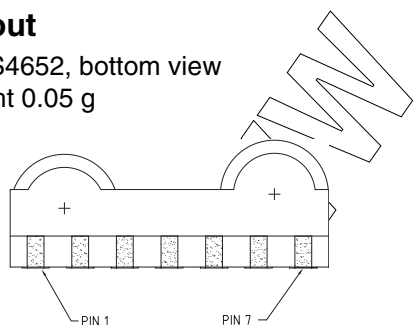

19284

Definitions:

In the Vishay transceiver data sheets the following nomenclature is used for defining the IrDA operating modes:

SIR: 2.4 kbit/s to 115.2 kbit/s, equivalent to the basic serial infrared standard with the physical layer version IrPhY 1.0

MIR: 576 kbit/s to 1152 kbit/s

FIR: 4 Mbit/s

VFIR: 16 Mbit/s

MIR and FIR were implemented with IrPhY 1.1, followed by IrPhY 1.2, adding the SIR Low Power Standard. IrPhY 1.3 extended the Low Power Option to MIR and FIR and VFIR was added with IrPhY 1.4. A new version of the standard in any case obsoletes the former version.

Absolute Maximum Ratings

Reference point Pin, GND unless otherwise noted.

Typical values are for DESIGN AID ONLY, not guaranteed nor subject to production testing.

Parameter	Test Conditions	Symbol	Min	Typ.	Max	Unit
Supply voltage range, transceiver	$0\text{ V} < V_{CC2} < 6\text{ V}$	V_{CC1}	- 0.5		6.0	V
Supply voltage range, transmitter	$0\text{ V} < V_{CC1} < 3.6\text{ V}$	V_{CC2}	- 0.5		6.0	V
Supply voltage range, digital supply	$0\text{ V} < V_{CC1} < 3.6\text{ V}$	V_{logic}	- 0.5		6.0	V
Voltage at RXD	All states	V_{in}	- 0.5		$V_{logic} + 0.5$	V
Input voltage range, transmitter TXD	Independent of V_{dd} or V_{logic}	V_{in}	- 0.5		6.0	V
Input currents	For all pins, except IRED anode pin		- 40		40	mA
Output sinking current					20	mA
Power dissipation		P_D			250	mW
Junction temperature		T_J			125	°C
Ambient temperature range (operating)		T_{amb}	- 25		+ 85	°C
Storage temperature		T_{stg}	- 40		+ 100	°C
Soldering temperature (***)	see section Recommended Solder Profile					°C
Repetitive pulse output current	$< 90\text{ }\mu\text{s}$, $t_{on} < 20\%$	$I_{IRED (RP)}$			500	mA
Average output current (transmitter)		$I_{IRED (DC)}$			100	mA
Virtual source size	Method: (1-1/e) encircled energy	d	0.8			mm
Maximum Intensity for Class 1	IEC60825-1 or EN60825-1, edition Jan. 2001	I_e			^{*)} (500) ^{**)}	mW/sr

^{*)}Due to the internal limitation measures the device is a 'class1' device.

^{**)}IrDA specifies the max. intensity with 500 mW/sr

^{***)}Sn/Pb-free soldering. The product passed VISHAY's standard convection reflow profile soldering test.

Electrical Characteristics

Transceiver

$T_{amb} = 25\text{ }^{\circ}\text{C}$, $V_{CC} = 2.4\text{ V}$ to 3.6 V unless otherwise noted.

Typical values are for DESIGN AID ONLY, not guaranteed nor subject to production testing.

Parameter	Test Conditions	Symbol	Min	Typ.	Max	Unit
Supply voltage range		V_{CC}	2.4		3.6	V
Dynamic Supply current						
Idle, dark ambient	SD = Low (< 0.8 V), $E_{eamb} = 0\text{ klx}$, $E_e < 4\text{ mW/m}^2$ $-25\text{ }^{\circ}\text{C} \leq T \leq +85\text{ }^{\circ}\text{C}$	I_{CC}		90	130	μA
Idle, dark ambient	SD = Low (< 0.8 V), $E_{eamb} = 0\text{ klx}$, $E_e < 4\text{ mW/m}^2$ $T = +25\text{ }^{\circ}\text{C}$	I_{CC}		75		μA
Peak supply current during transmission	SD = Low, TXD = High	I_{CCpk}		2	3	mA
Idle, dark ambient @ V_{logic} - pin	SD = Low (< 0.8 V), $E_{eamb} = 0\text{ klx}$, $E_e < 4\text{ mW/m}^2$	I_{logic}			1	μA
Shutdown supply current Dark ambient	SD = High ($> V_{logic} - 0.5\text{ V}$), $T = 25\text{ }^{\circ}\text{C}$, $E_e = 0\text{ klx}$	I_{SD}			0.1	μA
Shutdown supply current, dark ambient	SD = High ($> V_{logic} - 0.5\text{ V}$), $T = 70\text{ }^{\circ}\text{C}$, $E_e = 0\text{ klx}$	I_{SD}			2.0	μA
Shutdown supply current, dark ambient	SD = High ($> V_{logic} - 0.5\text{ V}$), $T = 85\text{ }^{\circ}\text{C}$, $E_e = 0\text{ klx}$	I_{SD}			3.0	μA
Operating temperature range		T_A	-25		+85	$^{\circ}\text{C}$
Output voltage low	$I_{OL} = 0.2\text{ mA}$, $V_{CC} = 2.4\text{ V}$ $C_{load} = 15\text{ pF}$	V_{OL}		0.3		V
Output voltage high	$I_{OL} = 0.2\text{ mA}$, $V_{CC} = 2.4\text{ V}$ $C_{load} = 15\text{ pF}$	V_{OH}	$V_{logic} - 0.5$		V_{logic}	V
Rxd to V_{CC} pull-up impedance	SD = V_{CC} , $V_{CC} = 2.4\text{ V}$ to 5 V	R_{Rxd}		500		$\text{k}\Omega$
Input voltage low (Txd, SD)		V_{IL}	-0.5		0.5	V
Input voltage high (Txd, SD)	$V_{CC} = 2.4\text{ V}$ to 3.6 V	V_{IH}	$V_{logic} - 0.5$		$V_{logic} + 0.5$	V
Input voltage threshold SD	$V_{CC} = 2.4\text{ V}$ to 3.6 V		0.9	$0.5 \times V_{logic}$	$0.66 \times V_{logic}$	V
Input capacitance (Txd, SD)		C_1			6	pF



Optoelectronic Characteristics

Receiver

T_{amb} = 25 °C, V_{CC} = 2.4 V to 3.6 V unless otherwise noted.

Typical values are for DESIGN AID ONLY, not guaranteed nor subject to production testing.

Parameter	Test Conditions	Symbol	Min	Typ.	Max	Unit
Sensitivity: Minimum irradiance E _e in angular range *)**)	9.6 kbit/s to 115.2 kbit/s λ = 850 nm to 900 nm	E _e		40 (4.0)	81 (8.1)	mW/m ² (μW/cm ²)
Maximum irradiance E _e in angular range ***)	λ = 850 nm to 900 nm	E _e	5 (500)			kW/m ² (mW/cm ²)
No output receiver input irradiance	According to IrDA IrPHY 1.4, Appendix A1, fluorescent light specification	E _e		4 (0.4)		mW/m ² (μW/cm ²)
Rise time of output signal	10 % to 90 %, C _L = 15 pF	t _{r (Rxd)}	20		100	ns
Fall time of output signal	90 % to 10 %, C _L = 15 pF	t _{f (Rxd)}	20		100	ns
Rxd pulse width of output signal, 50%	Input pulse width 1.63 μs	t _{PW}	1.7		2.9	μs
Receiver start up time	Power on delay			100	150	μs
Latency		t _L	30	50	100	μs

*) This parameter reflects the backlight test of the IrDA physical layer specification to guarantee immunity against light from fluorescent lamps

***) IrDA sensitivity definition: **Minimum Irradiance E_e In Angular Range**, power per unit area. The receiver must meet the BER specification while the source is operating at the minimum intensity in angular range into the minimum half-angle range at the maximum Link Length

****) **Maximum Irradiance E_e In Angular Range**, power per unit area. The optical delivered to the detector by a source operating at the maximum intensity in angular range at **Minimum Link Length** must not cause receiver overdrive distortion and possible related link errors. If placed at the Active Output Interface reference plane of the transmitter, the receiver must meet its bit error ratio (BER) specification.

For more definitions see the document "Symbols and Terminology" on the Vishay Website (<http://www.vishay.com/docs/82512/82512.pdf>).

Transmitter

$T_{amb} = 25\text{ }^{\circ}\text{C}$, $V_{CC} = 2.4\text{ V}$ to 3.6 V unless otherwise noted.

Typical values are for DESIGN AID ONLY, not guaranteed nor subject to production testing.

Parameter	Test Conditions	Symbol	Min	Typ.	Max	Unit
IRED operating current, current controlled	The IRED current is internally controlled but also can be reduced by an external resistor	I_D	200		400	mA
Output leakage IRED current	$T_{amb} = 85\text{ }^{\circ}\text{C}$	I_{IRED}			1	μA
Output radiant intensity *)	$\alpha = 0^{\circ}, 15^{\circ}$, Txd = High, SD = Low, $V_{CC1} = 3.0\text{ V}$, $V_{CC2} = 3.0\text{ V}$, $R_s = 30\ \Omega$ (resulting in about 50 mA drive current)	I_e	4		150	mW/sr
Output radiant intensity *)	$\alpha = 0^{\circ}, 15^{\circ}$, Txd = High, SD = Low, $V_{CC1} = 3.0\text{ V}$, $V_{CC2} = 3.0\text{ V}$, $R_s = 0\ \Omega$, $I_f = 300\text{ mA}$	I_e		25		mW/sr
Output radiant intensity *	$V_{CC1} = 5.0\text{ V}$, $\alpha = 0^{\circ}, 15^{\circ}$ Txd = Low or SD = High (Receiver is inactive as long as SD = High)	I_e			0.04	mW/sr
Saturation voltage of IRED driver	$V_{CC} = 3.0\text{ V}$, $I_f = 50\text{ mA}$	V_{CEsat}		0.4		V
Peak - emission wavelength		λ_p	880	886	900	nm
Optical rise time, Optical fall time		t_{ropt} t_{fopt}	20		100	ns
Optical output pulse duration	Input pulse width $t < 30\ \mu\text{s}$ Input pulse width $t \geq 30\ \mu\text{s}$	t_{opt} t_{opt}	30	t 50	300	μs μs
Optical output pulse duration	Input pulse width $t = 1.63\ \mu\text{s}$	t_{opt}	1.45	1.61	2.2	μs
Optical overshoot					20	%

*)The radiant intensity can be adjusted by the external current limiting resistor to adapt the intensity to the desired value. The given value is for minimum current consumption. This transceiver can be adapted to > 50 cm operation by increasing the current to > 200 mA, e.g. operating the transceiver without current control resistor and using the internal current control.

Table 1.
Truth table

Inputs			Outputs	
SD	Txd	Optical input Irradiance mW/m^2	Rxd	Transmitter
high	x	x	Tri-state floating	0
low	high	x	high (echo off)	I_e
low	high > 100 μs	x	high	0
low	low	< 2	high	0
low	low	> Min. irradiance E_e < Max. irradiance E_e	low (active)	0
low	low	> Max. irradiance E_e	x	0

Recommended Circuit Diagram

Operated at a clean low impedance power supply the TFBS4652 needs only one additional external component when the IRED drive current should be minimized for minimum current consumption according the low power IrDA standard. When combined operation in IrDA and Remote Control is intended no current limiting resistor is recommended. When long wires are used for bench tests, the capacitors are mandatory for testing rise/fall time correctly.

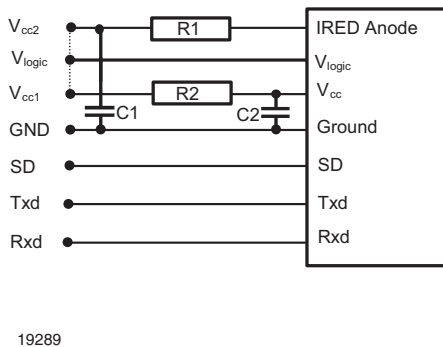

19289

Figure 1. Recommended Application Circuit

The capacitor C1 is buffering the supply voltage V_{CC2} and eliminates the inductance of the power supply line. This one should be a small ceramic version or other fast capacitor to guarantee the fast rise time of the IRED current. The resistor R1 is necessary for controlling the IRED drive current when the internally controlled current is too high for the application.

Vishay transceivers integrate a sensitive receiver and a built-in power driver. The combination of both needs a careful circuit board layout. The use of thin, long, resistive and inductive wiring should be avoided. The inputs (Txd, SD) and the output Rxd should be directly (DC) coupled to the I/O circuit.

The capacitor C2 combined with the resistor R2 is the low pass filter for smoothing the supply voltage.

As already stated above R2, C1 and C2 are optional and depend on the quality of the supply voltages V_{CCx} and injected noise. An unstable power supply with dropping voltage during transmission may reduce the sensitivity (and transmission range) of the transceiver.

The placement of these parts is critical. It is strongly recommended to position C2 as close as possible to

the transceiver power supply pins.

When connecting the described circuit to the power supply, low impedance wiring should be used.

In case of extended wiring the inductance of the power supply can cause dynamically a voltage drop at V_{CC2} . Often some power supplies are not apply to follow the fast current rise time. In that case another 10 μ F cap at V_{CC2} will be helpful.

Keep in mind that basic RF-design rules for circuit design should be taken into account. Especially longer signal lines should not be used without termination. See e.g. "The Art of Electronics" Paul Horowitz, Wienfield Hill, 1989, Cambridge University Press, ISBN: 0521370957

Table 2.

Recommended Application Circuit Components

Component	Recommended Value
C1, C2	0.1 μ F, Ceramic, Vishay part# VJ 1206 Y 104 J XXMT
R1	See table 3
R2	47 Ω , 0.125 W ($V_{CC1} = 3$ V)

Table 3.

Recommended resistor R1 [Ω]

V_{CC2} [V]	Minimized current consumption, IrDA Low power compliant
2.7	24
3.0	30
3.3	36

Recommended Solder Profiles for TFBS4652

Solder Profile for Sn/Pb soldering

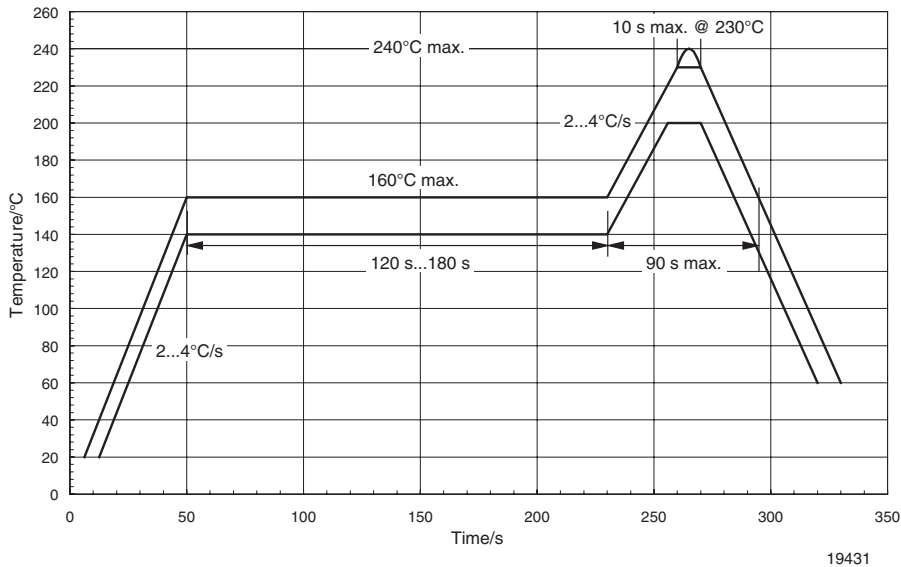

Figure 2. Recommended Solder Profile for Sn/Pb soldering

Lead-Free, Recommended Solder Profile

The TFBS4652 is a lead-free transceiver and qualified for lead-free processing. For lead-free solder paste like $\text{Sn}_{(3.0 - 4.0)}\text{Ag}_{(0.5 - 0.9)}\text{Cu}$, there are two standard reflow profiles: Ramp-Soak-Spike (RSS) and Ramp-To-Spike (RTS). The Ramp-Soak-Spike profile was developed primarily for reflow ovens

heated by infrared radiation. With widespread use of forced convection reflow ovens the Ramp-To-Spike profile is used increasingly. Shown below in figure 4 is Vishay's recommended profile for use with the TFBS4652 transceivers. For more details please refer to Application note: [SMD Assembly Instruction](#).

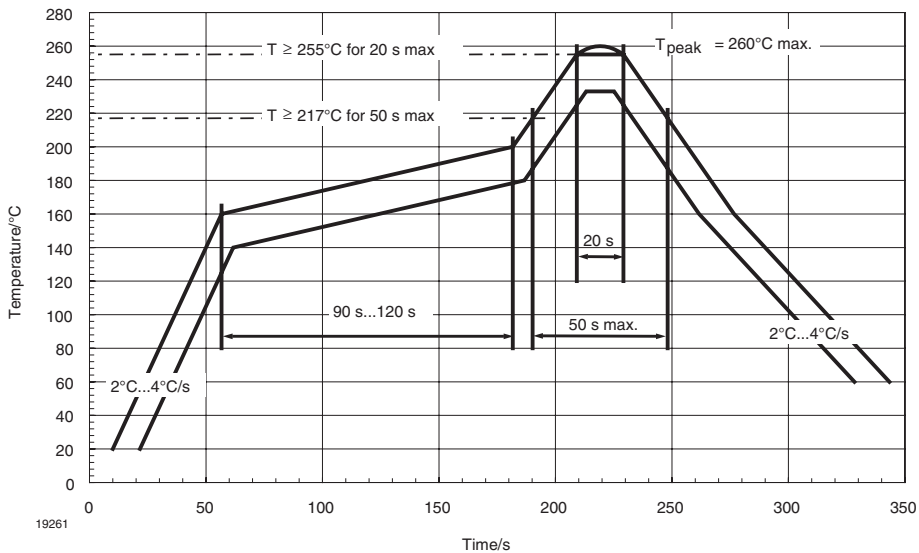
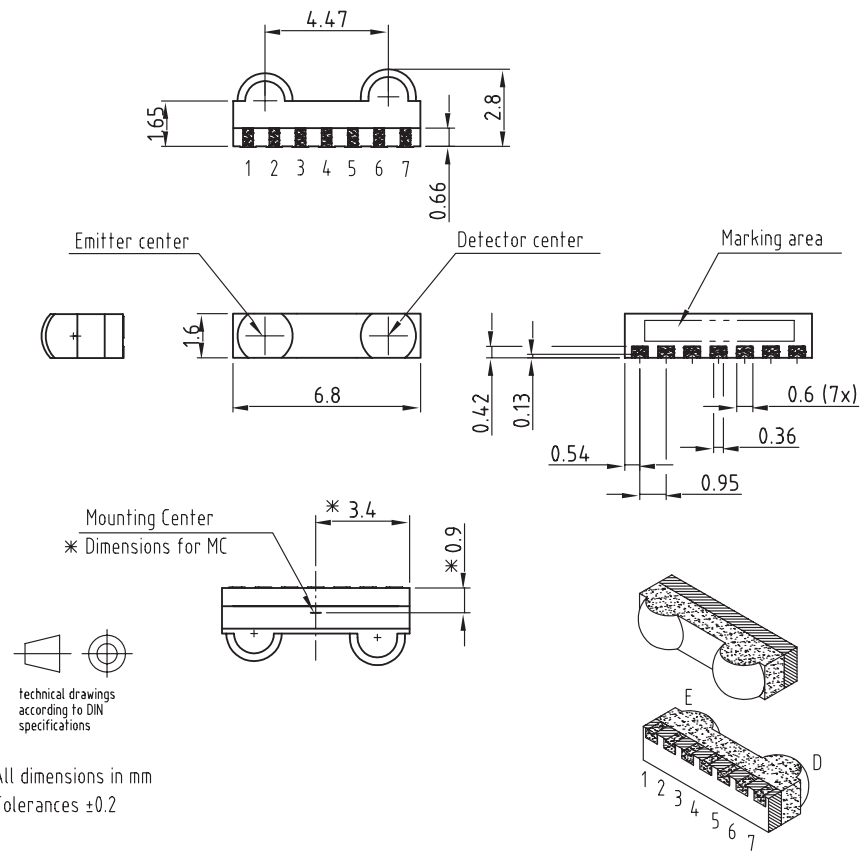

Figure 3. Solder Profile, RSS Recommendation

Package Dimensions in mm



Drawing refers to following types: TFBS 4650
TFBS 4652

Drawing-No.: 6.550-5268.01-4
Issue: 1; 04.02.05

19322

Figure 4: TFBS4652 mechanical dimensions, tolerance $\pm 0.2m$, if not otherwise mentioned

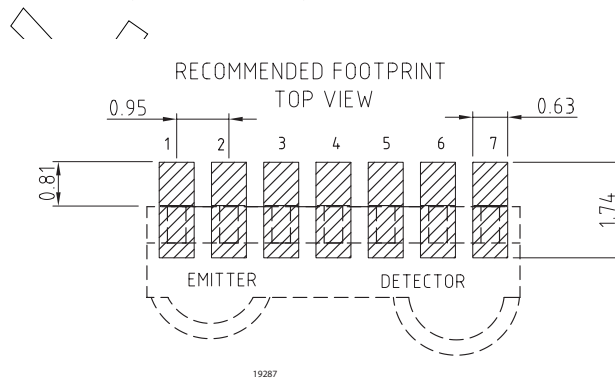
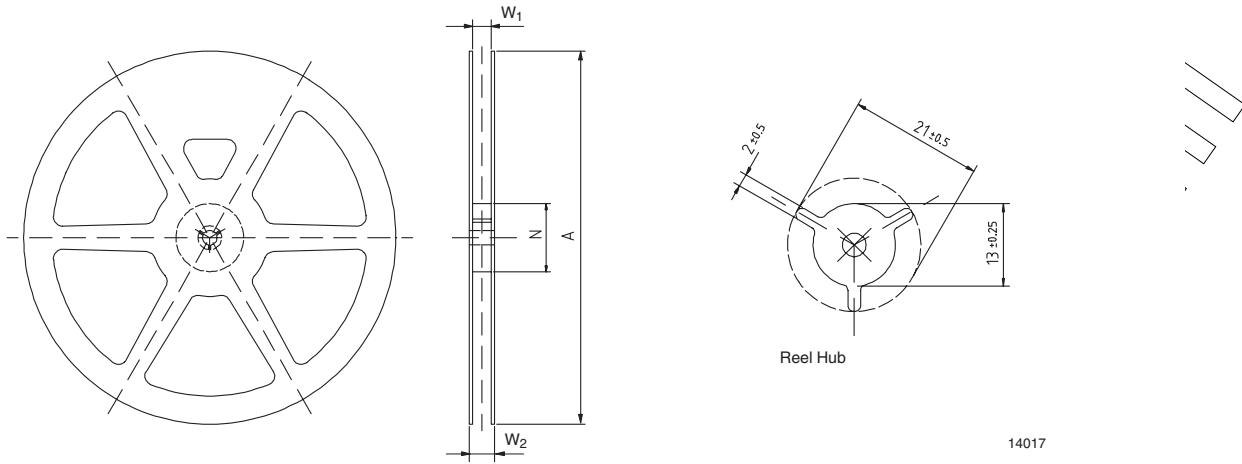

Figure 5: TFBS4652 soldering footprint, tolerance $\pm 0.2m$, if not otherwise mentioned

Reel Dimensions



14017

Tape Width	A max.	N	W_1 min.	W_2 max.	W_3 min.	W_3 max.
mm	mm	mm	mm	mm	mm	mm
16	330	50	16.4	22.4	15.9	19.4

www.vishay.com

Tape Dimensions in mm

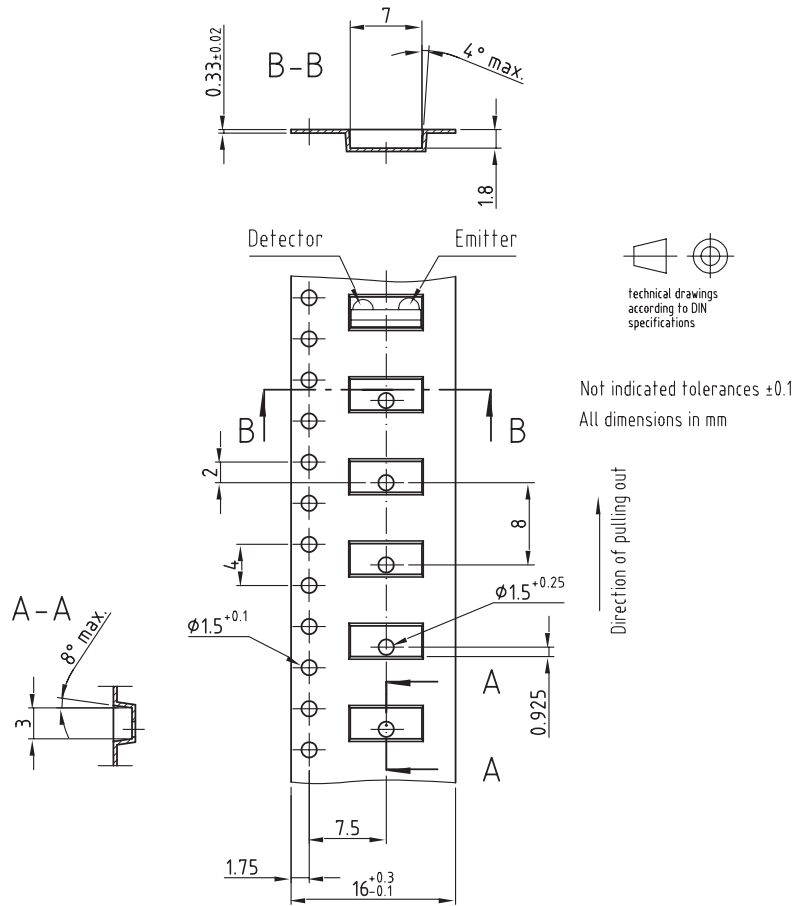

Drawing-No.: 9.700-5296.01-4
Issue: prel. copy; 24.11.04

Drawing refers to following types: TFBS 4650
TFBS 5700

19286

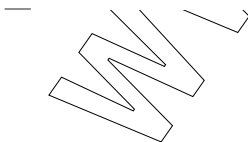

Ozone Depleting Substances Policy Statement

It is the policy of Vishay Semiconductor GmbH to

1. Meet all present and future national and international statutory requirements.
2. Regularly and continuously improve the performance of our products, processes, distribution and operating systems with respect to their impact on the health and safety of our employees and the public, as well as their impact on the environment.

It is particular concern to control or eliminate releases of those substances into the atmosphere which are known as ozone depleting substances (ODSs).

The Montreal Protocol (1987) and its London Amendments (1990) intend to severely restrict the use of ODSs and forbid their use within the next ten years. Various national and international initiatives are pressing for an earlier ban on these substances.

Vishay Semiconductor GmbH has been able to use its policy of continuous improvements to eliminate the use of ODSs listed in the following documents.

1. Annex A, B and list of transitional substances of the Montreal Protocol and the London Amendments respectively
2. Class I and II ozone depleting substances in the Clean Air Act Amendments of 1990 by the Environmental Protection Agency (EPA) in the USA
3. Council Decision 88/540/EEC and 91/690/EEC Annex A, B and C (transitional substances) respectively.

Vishay Semiconductor GmbH can certify that our semiconductors are not manufactured with ozone depleting substances and do not contain such substances.

We reserve the right to make changes to improve technical design and may do so without further notice.

Parameters can vary in different applications. All operating parameters must be validated for each customer application by the customer. Should the buyer use Vishay Semiconductors products for any unintended or unauthorized application, the buyer shall indemnify Vishay Semiconductors against all claims, costs, damages, and expenses, arising out of, directly or indirectly, any claim of personal damage, injury or death associated with such unintended or unauthorized use.

Vishay Semiconductor GmbH, P.O.B. 3535, D-74025 Heilbronn, Germany