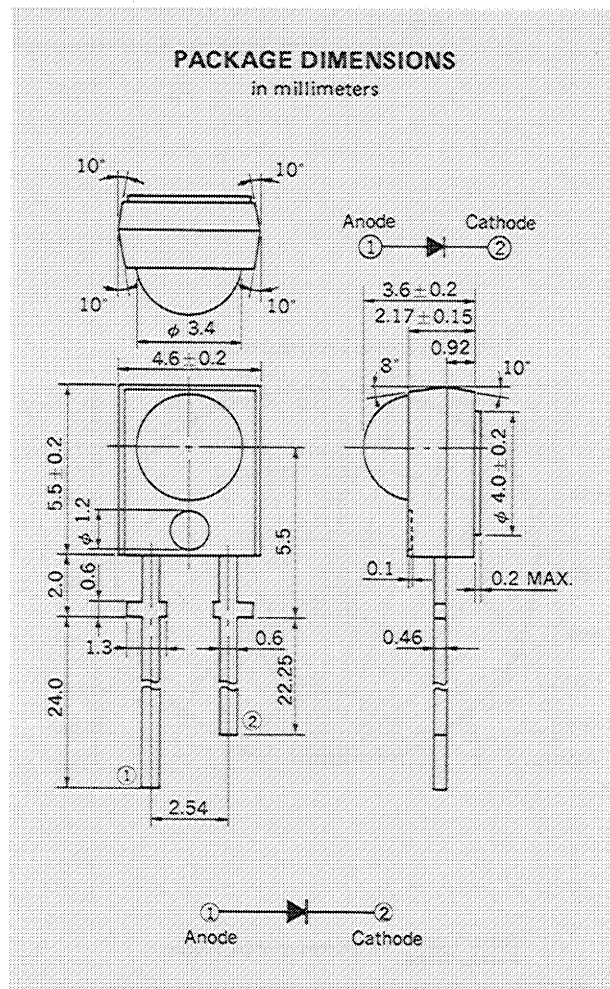

**PLASTIC MOLDED PIN PHOTO DIODE**

— NEPOC SERIES —

**DESCRIPTION**

PH310 is a photo diode with PIN structure. It has a wide photo-receiving area and high speed response enabling applications for various remote controlling equipments. The resin material itself used for the package has filter effect to pass only infrared.

**FEATURES**

- Ultra high speed response. ( $t_r, t_f \cong 30$  ns)
- Coincidence of the wavelength of maximum sensitivity with that of an infrared LED. ( $\lambda_s$  MAX. = 990 nm)
- High sensitivity. [ $5 \mu\text{A}$  TYP. (@  $V_R = 5$  V,  $H = 0.1$  mW/cm<sup>2</sup>)]
- Wide dynamic range.

**ABSOLUTE MAXIMUM RATINGS**

Maximum Reverse Voltage ( $T_a = 25^\circ\text{C}$ )

$V_R$  32 V

Maximum Power Dissipation ( $T_a = 25^\circ\text{C}$ )

$P_D$  150 mW

Maximum Temperatures

Operating Temperature  $T_{opt}$   $-30$  to  $+85$   $^\circ\text{C}$

Storage Temperature  $T_{stg}$   $-40$  to  $+100$   $^\circ\text{C}$

**ELECTRO-OPTICAL CHARACTERISTICS ( $T_a = 25^\circ\text{C}$ )**

CHARACTERISTIC	SYMBOL	MIN.	TYP.	MAX.	UNIT	TEST CONDITIONS
Dark Current	$I_R$			10	nA	$V_R = 10\text{ V}$
Wavelength of the max. sensitivity	$\lambda_s \text{ MAX.}$		990		nm	
Quantum yield (Electron per photon)	$\eta$		0.88			$\lambda = 940\text{ nm}$
Spectral sensitivity	S	25	32		nA/lx	$V_R = 5\text{ V}$
Spectral sensitivity	$S_{IR}$	4.0	5.0		$\mu\text{A}$	$V_R = 5\text{ V}, H = 0.1\text{ mW/cm}^2 *$
Rise and fall time of the photocurrent from 10 % to 90 % and 90 % to 10 % of the final value	$t_r, t_f$		120		ns	$R_L = 1\text{ k}\Omega, V_R = 0\text{ V}, \lambda = 940\text{ nm}$
	$t_r, t_f$		30		ns	$R_L = 1\text{ k}\Omega, V_R = 5\text{ V}, \lambda = 940\text{ nm}$
Capacitance	$C_t$		11		pF	$V_R = 5\text{ V}, f = 1\text{ MHz}$
Radiant sensitive area	A		5.3		$\text{mm}^2$	

\*  $\lambda = 940\text{ nm}$

**TYPICAL CHARACTERISTICS ( $T_a = 25^\circ\text{C}$ )**

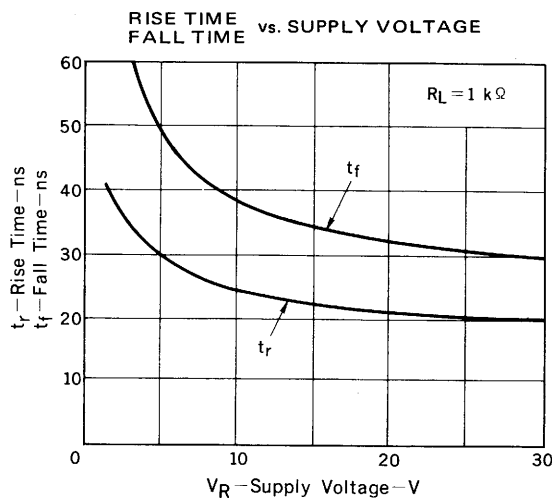
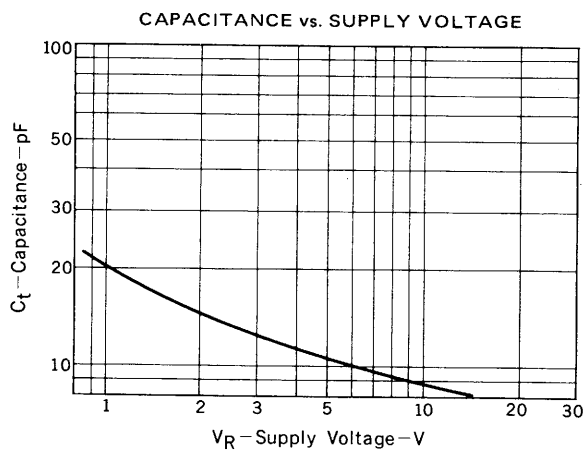
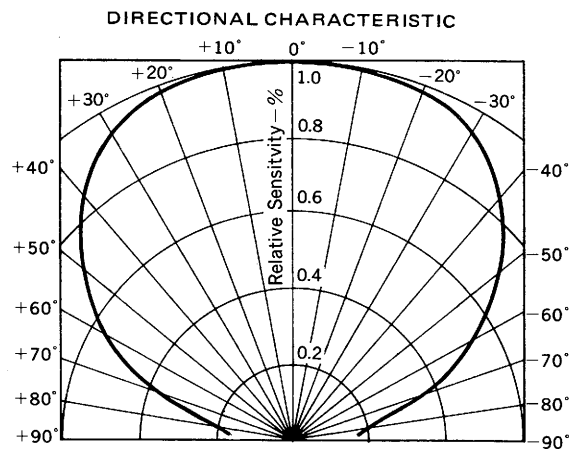
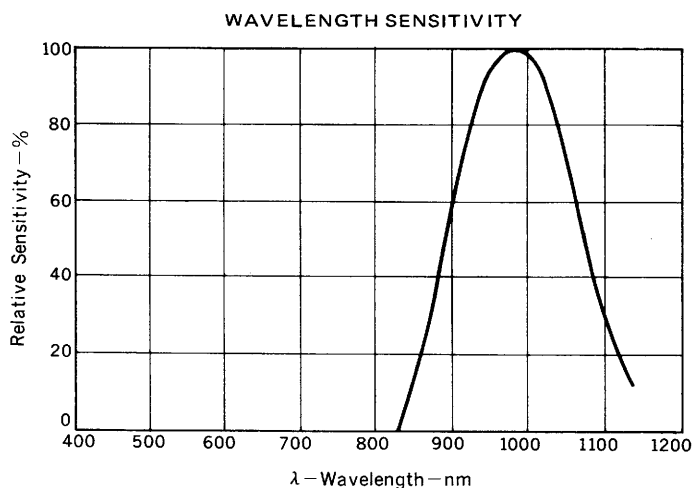

LEAK CURRENT vs. SUPPLY VOLTAGE

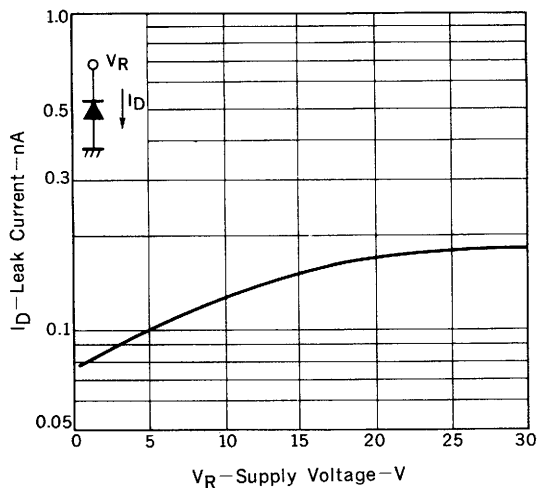

LEAK CURRENT vs. AMBIENT TEMPERATURE

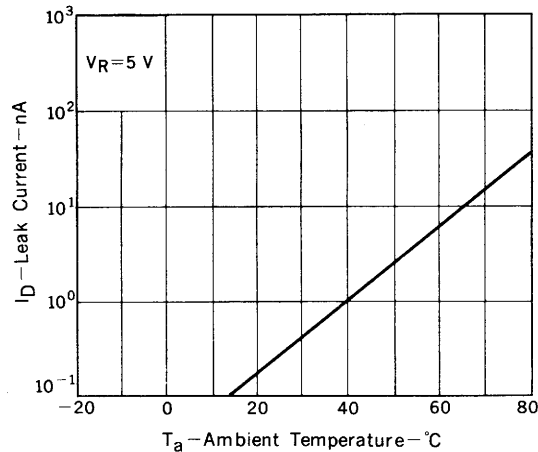
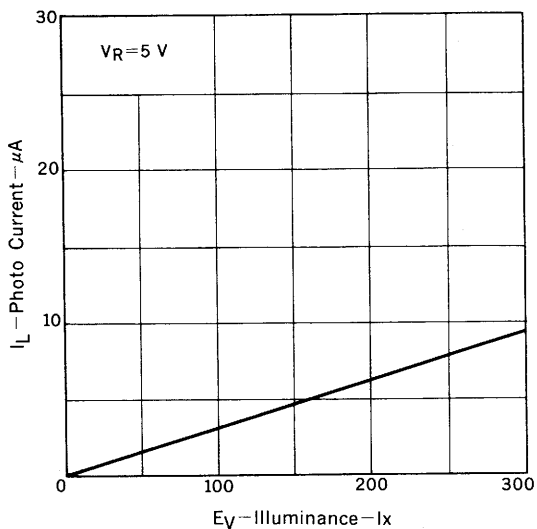

PHOTO CURRENT vs. ILLUMINANCE



RELATIVE vs. AMBIENT TEMPERATURE

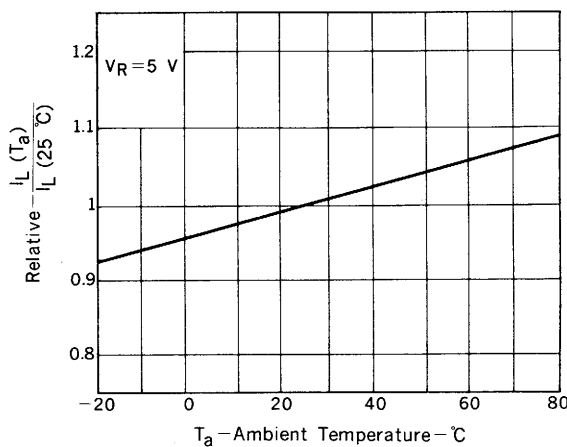

PHOTO CURRENT vs. SUPPLY VOLTAGE

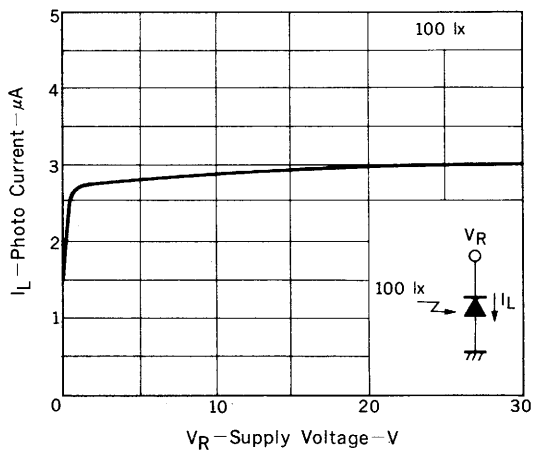
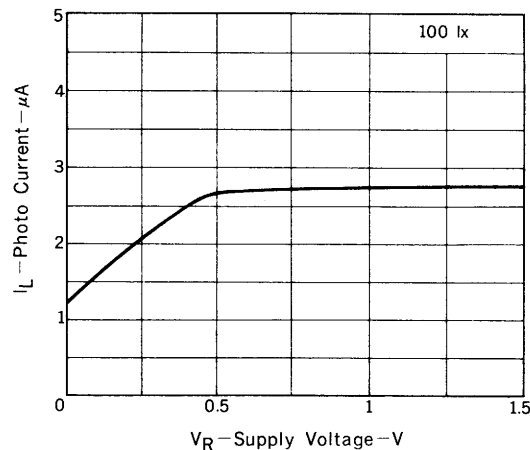
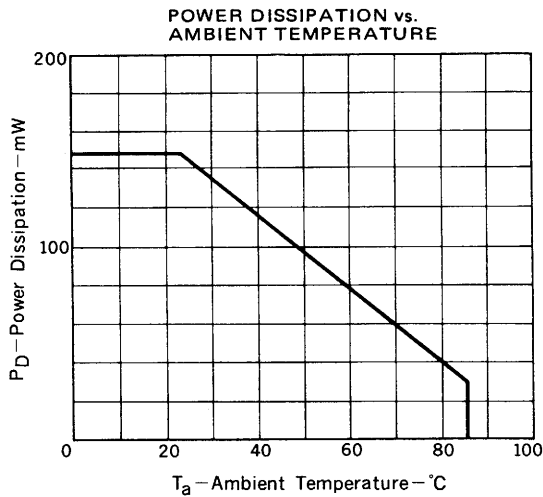

PHOTO CURRENT vs. SUPPLY VOLTAGE





#### HANDLING PRECAUTIONS:

1. The full resin-molded PH310 has generally a little less mechanical and thermal strength than other resin-molded semiconductor devices as they have less additives. Therefore please note on the following points.
  - (a) Soldering of leads should be made at the point 5 mm or more from the root of the leads at 260 °C and within 5 s.
  - (b) If the temperature of the molded portion rises in addition to the residual stress between the leads, the possibility that open or short circuit occurs due to the deformation or destruction of the resin will increase.
2. On cleaning the device:
  - (a) Cleaning with unsuitable solvent may impair the resin if the package and the following solvents should be used at the temperature of less than 45 °C and for less than 3 minutes of immersion time.
    - Freon TE, Freon TF, Ethanol, Methanol
    - Difron-solvent, Isopropyl-alcohol
  - (b) Ultrasonic cleaning will add some stress on devices. The degree of the stress differs depending on the oscillation output power, the size of the PCB and the mounting methods of the devices, therefore it should be confirmed by making an experiment at actual conditions that the cleaning does not have any problem on the devices.



[MEMO]

No part of this document may be copied or reproduced in any form or by any means without the prior written consent of NEC Corporation. NEC Corporation assumes no responsibility for any errors which may appear in this document.

NEC Corporation does not assume any liability for infringement of patents, copyrights or other intellectual property rights of third parties by or arising from use of a device described herein or any other liability arising from use of such device. No license, either express, implied or otherwise, is granted under any patents, copyrights or other intellectual property rights of NEC Corporation or of others.