

■ Description

The **ROM-N3xx...** Series are miniaturized receiver for infrared remote control system. The PIN Photodiode and preamplifier are assembled on lead frame. The epoxy package is designed as IR filter.

The module has excellent performance even in disturbed ambient light application and provides protection against uncontrolled output pulses.

■ Features

- Small size package.
- Wide Operating Supply voltage 2.7V ~ 5.5V
- Maximum interference safety against optical and electrical disturbance.
- Various band pass frequency.
(32.7kHz/36.7kHz/37.9kHz/40kHz/56.7kHz)
- Internal filter for a high frequency lighting fluorescent lamp.
- Open collector output.

■ Application

- AV instruments (VCR, TV, SVR, Audio, CD player)
- Home appliances (Air conditioner, Computer, Camera)
- Remote control for wireless equipment.
- Infrared remote control TOYs.

■ Outline Dimensions (Unit: mm)

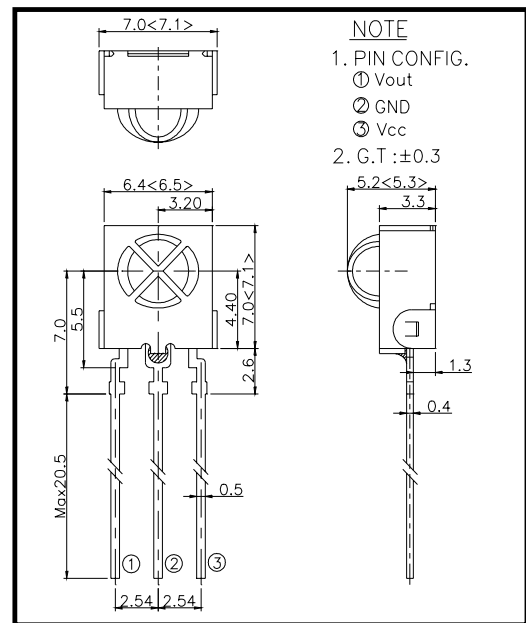

■ Block Diagram

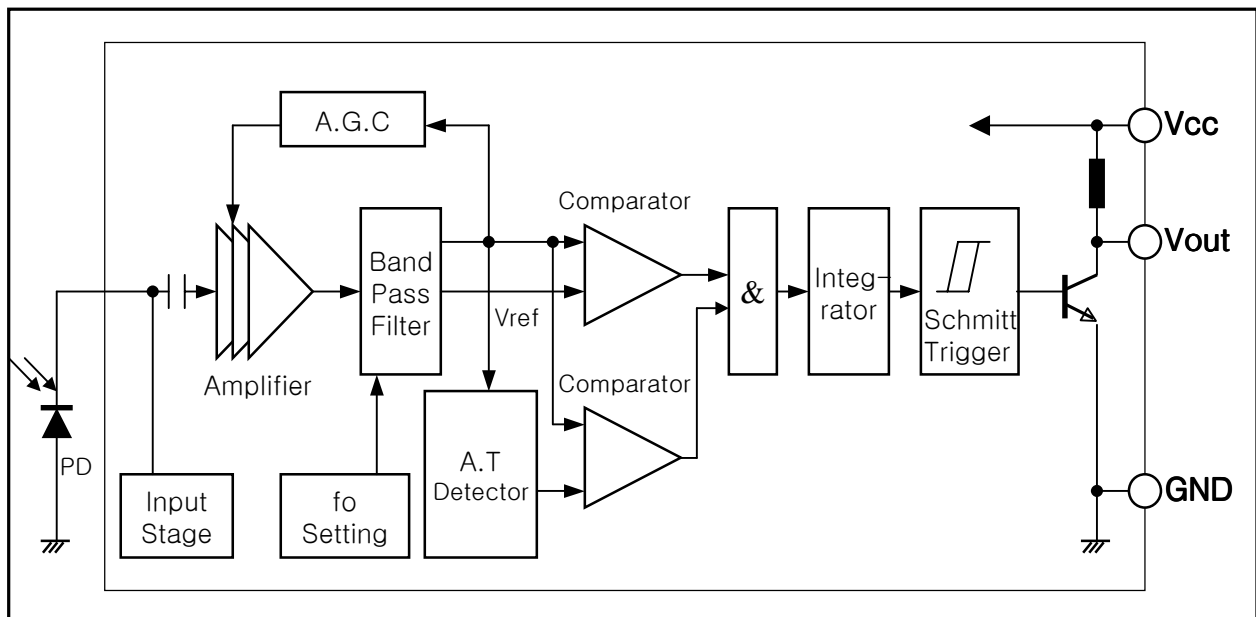

■ Absolute Maximum Ratings

(at 25°C Unless otherwise note)

Parameter	Symbol	Ratings	Unit
Supply Voltage	V _{cc}	6.5	V
Output Current	I _{out}	2.0	mA
Operating Temperature	T _{opr}	-20 ~ +80	°C
Storage Temperature	T _{stg}	-25 ~ +85	°C
Soldering Temperature	T _{sol}	260, t < 5sec	°C

■ Recommended Operating Conditions

Parameter	Symbol	Ratings	Unit
Operating Voltage	V _{cc}	2.7 ~ 5.5	V
Input Frequency	f _{in}	30 ~ 60	kHz

■ Electro-Optical Characteristics

 (T_a=25°C)

Parameter	Symbol	Conditions	Min	Typ	Max	Unit
Supply Voltage	V _{cc}		2.7	-	5.5	V
Supply Current	I _{cc}	No signal input	-	1.1	1.3	mA
Peak Wavelength(*1)	λ _p		-	940	-	nm
Arrival Distance(*1)	L	Standard Signal	10	13	-	m
B.P.F Center Frequency(*2)	f _o		-	37.9	-	kHz
High Level Output Voltage(*1)	V _{OH}		V _{cc} -0.5	-	-	V
Low Level Output Voltage(*1)	V _{OL}		-	0.2	0.4	V
High Level Output Pulse Width(*1)	t _{WH}	Burst Wave =600μs Period = 1.2ms	500	600	700	μs
Low Level Output Pulse Width(*1)	t _{WL}		500	600	700	μs
Directivity(Half Angle)	Θ _{1/2}		-	±40	-	deg
Output Form	Active Low Output					

(*1) Distance between emitter and detector specifies maximum distance that output wave form satisfies the standard (fig.2) under the conditions below against the standard transmitter. ON/OFF pulse width is to be satisfied within 0.3m~ arrival distance length.

(*2) B.P.F center frequency(f_o) for varies with model is show below

Model No.	B.P.F frequency(kHz)
ROM-N332○○	32.7
ROM-N336○○	36.7
ROM-N338○○	37.9
ROM-N340○○	40.0
ROM-N356○○	56.7

■ Measurement Conditions

- Output pulse width

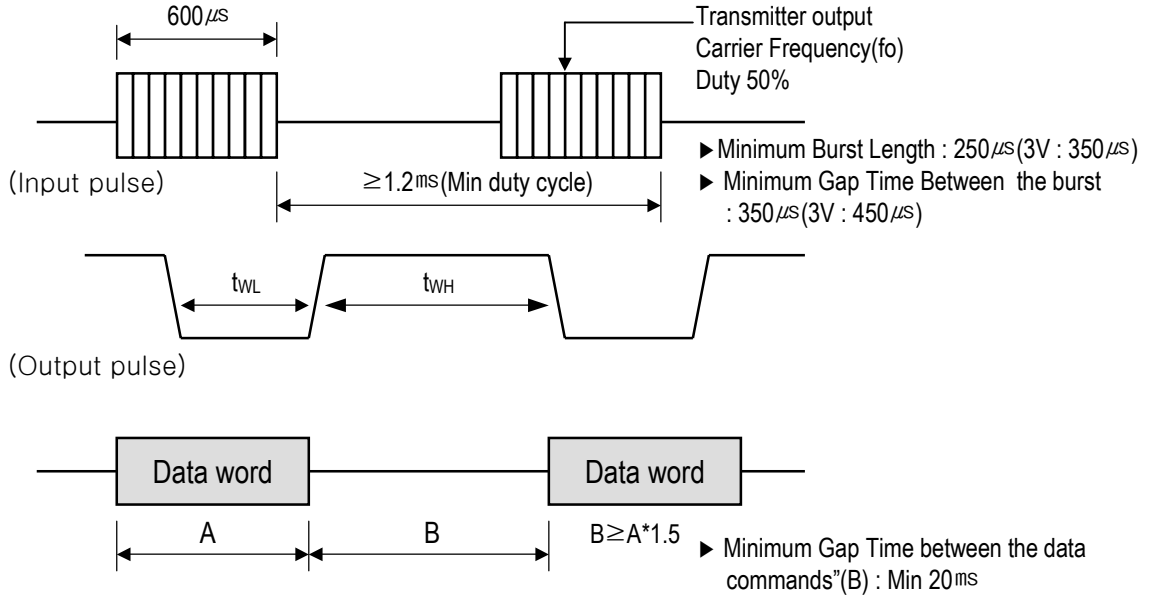

[Fig1. Burst wave, Output wave]

- Application circuit

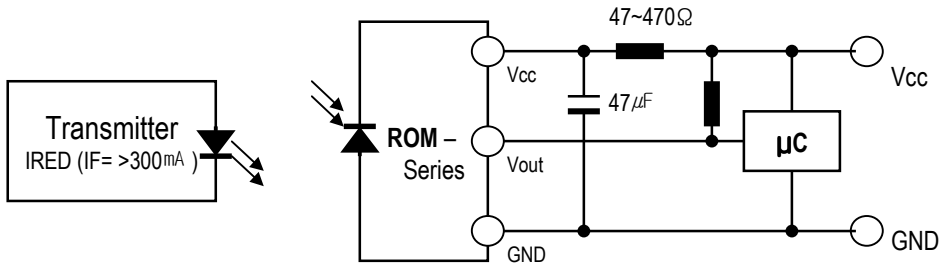

[Fig2. Transmitter, Power Supply Circuit]

- Test condition of arrival distance

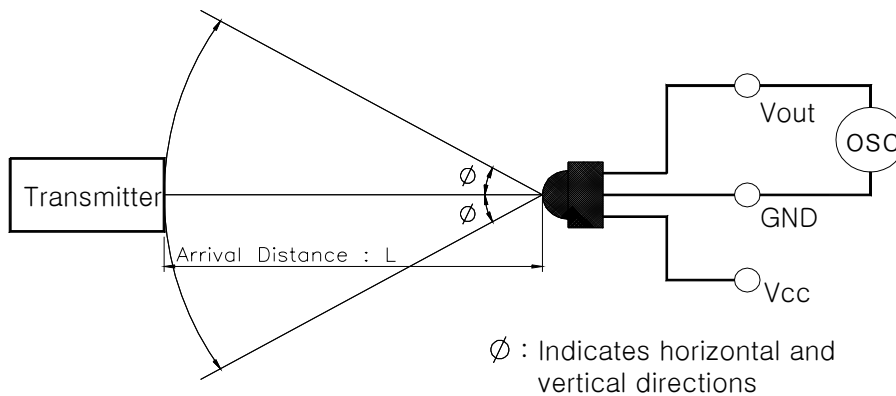

[Fig3. Measurement condition for arrival distance]

☞ Ambient light source : Detecting surface illumination shall be irradiate 200 ± 50 Lux under ordinary white fluorescence lamp without high frequency lighting

Reliability Test Items

Parameter	Conditions
High Temperature	Ta=+60℃, Vcc=5.0V t = 240h
High Temperature/High Humidity	Ta=+60℃, 90%RH, Vcc=5.0V t = 240h
Low Temperature	Ta=-10℃, Vcc=5.0V t = 240h
Heat Cycle	Ta=-20℃(0.5h)~+75℃(0.5h) 20cycle

☞ Electro-optical characteristics shall be satisfied after leaving 2 hours in the normal temperature.

Standard Inspection

1 Among electrical characteristics, total quantity shall be inspected as below.

- 1-1 Front distance between emitter and detector
- 1-2 Current consumption
- 1-3 High level output voltage
- 1-4 Low level output voltage

Typical Characteristics (Ta= 25℃)

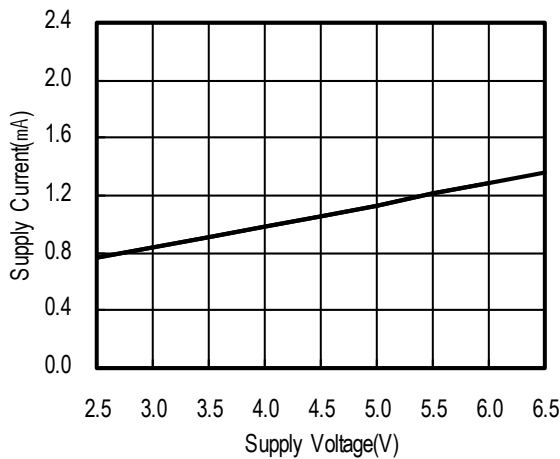

Fig.1 Supply Current vs. Supply Voltage

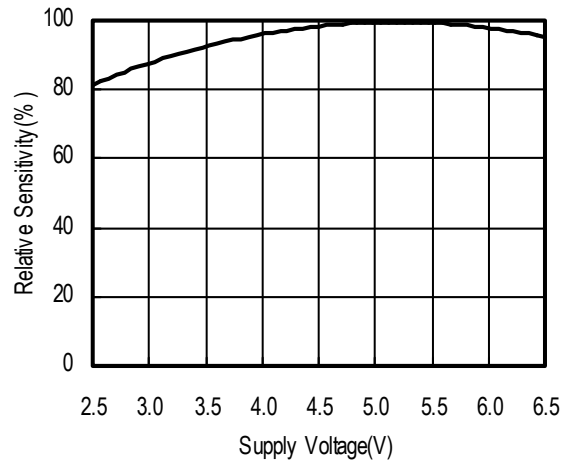

Fig.2 Relative Sensitivity vs. Supply Voltage

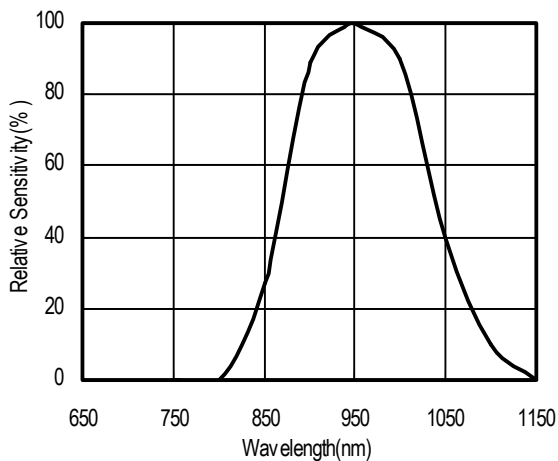

Fig.3 Relative Spectral Sensitivity vs. Wavelength

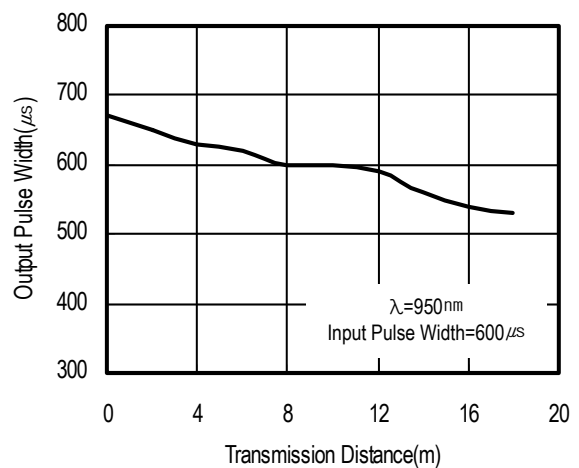
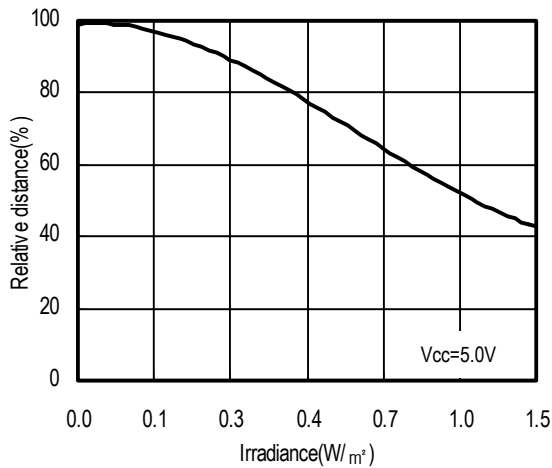
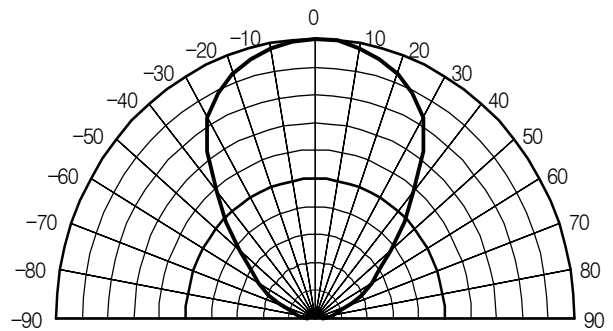

Fig.4 Output Pulse Width vs. Distance

Fig.5 Sensitivity vs. Bright Ambient

Fig.6 Sensitivity Angle Characteristics

■ Caution

- 1 The performance of remote control system depends on environment condition and ability of peripheral parts. Thus, it is highly recommended to evaluate the performance of the receiver module using the final product after the receiver module is assembled with peripheral components such as resistor, condenser, MICOM, and so on.
- 2 Store and use where there is no force causing transformation or change in quality.
- 3 Store and use when there is no extreme humidity.
- 4 Solder the lead-pin within the condition of ratings.
- 5 To prevent static electricity damage to the product. make sure that the human body and the soldering iron are connected to ground before using.
- 6 Put decoupling condenser(47 μ F~470 μ F) between Vcc and GND for reducing the noise from power supply line.
- 7 When a disturbance signal is applied to the ROM-Series, it can still receive the data signal. However, the sensitivity is reduced to the level that no unexpected pulses will occur. Some examples for such disturbance signals which are suppressed by the ROM-Series are :
 - .DC light.(ex. From tungsten lamp or sunlight)
 - .Continuous signal at center frequency or at any other frequency.
 - .Signals from fluorescent lamps with electronic ballast with high or low modulation.

■ Others

In case where any trouble or questions arise, both parties agree to make full discussion covering the said problem.