

Thermopile Infrared Detectors

Array Module

TPAM 166 L3.9

Thermopile Matrix Array with 4x4 Elements

Plug-In Module with Stored Calibration Data

Integrated Optics, Multiplexer, Amplifier, Reference and Self Test Function

Designed for Industrial Temperature Measurements

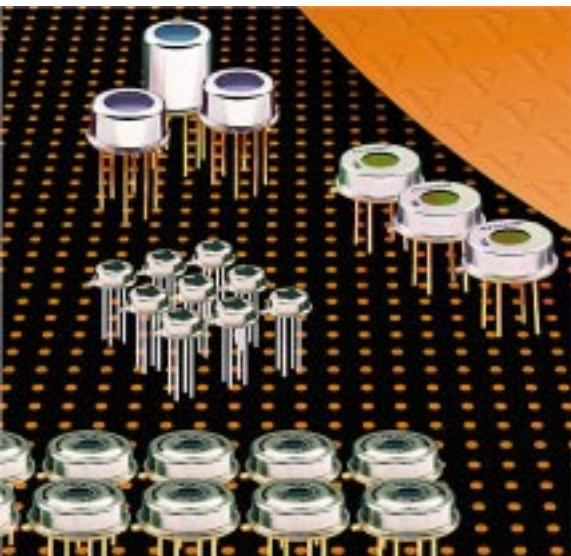

The integrated **ThermoPile Array** Sensor consists of a 4x4-elements thermopile chip connected to a multiplexing signal conditioning circuit. The sensor is further equipped with an internal temperature sensor for correct target temperature determination. All analogue signals, including the ambient temperature, are given out in a fixed frame, containing the information in one serial stream. Lenses for different field of views are available on demand. The sensor in a TO-5 housing is mounted on a small pcb with calibration data for this specific sensor stored in an E²PROM.

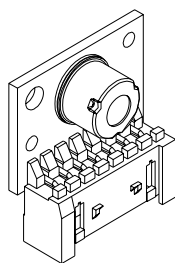

Parameters	TPAM	166L3.9	
	typical	units	condition
Field of view	41 x 32	°	f/1, f = 3.9mm
Output voltage	0.95	V	T _{BB} = 80°, T _{amb} = 20°
Output noise	0.4	mV/√Hz	0.5...20Hz
Object temperature	-20	100	°C
Operating voltage V_{DD}	5	V	500K BB 5...14μm
Operating current	1	mA	500K BB 5...14μm
Zero signal offset V_{ref}	V _{DD} /2	V	
Output resistance	200	Ω	
Power up time	0,3	s	
Sample frequency	3	kHz	
Storage temperature	-40	100	°C
Operating temperature	-20	100	°C
Temperature ref slope S_T	10	mV/K	V _{Temp} = S _T T _{amb} / K + V ₀
Temperature ref offset V₀	0	mV	

Right for modification reserved / WS / 21.5.2001

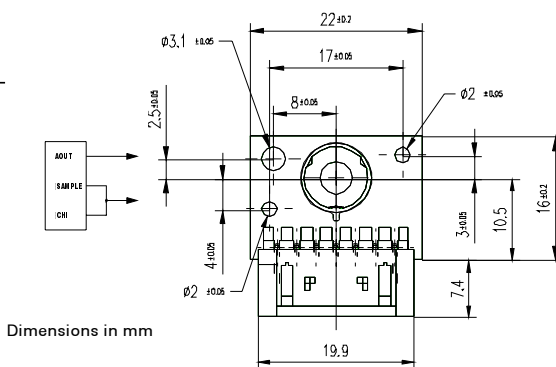
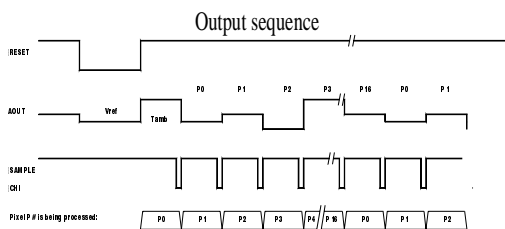
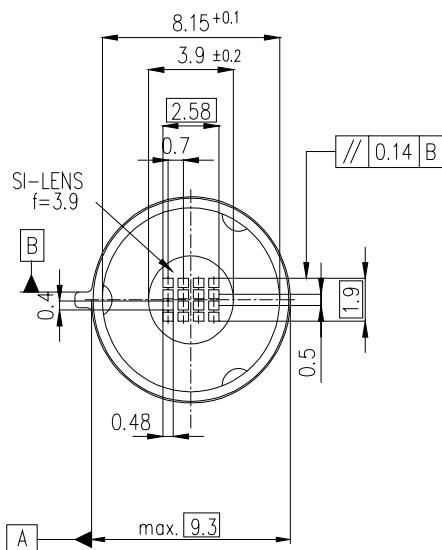

Dimensions in mm

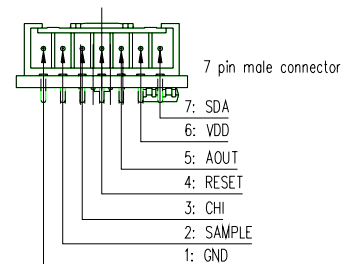

Europe:
PerkinElmer Optoelectronics GmbH
 Wenzel Jaksch Str 31
 Wiesbaden / Germany
 Phone +49(0)611 492 0
 Fax +49(0)611 492 170

USA:
PerkinElmer Optoelectronics
 2175 Mission College Blvd
 Santa Clara, CA 95054
 Phone +408 565 0830
 Fax +408 565 0703

Asia:
PerkinElmer Optoelectronics
 47, Ayer Rajah Crescent #06-12
 Singapore 139947
 Phone +65 775 2022
 Fax +65 775 1008

