

MESSRS.: _____

AGENT : _____

**SPECIFICATION
of
THERMOPILE
INFRARED SENSOR
UNIT**

MODEL NO. : TSUP-4B

PART NO. : _____

 **NIPPON CERAMIC CO., LTD.**

15-2 Nan-ei-cho, Tottori-shi, 689-1193 JAPAN
TEL : +81-857-53-3600 FAX : +81-857-53-3675

APPROVED BY	CHECKED BY	DRAWN BY

MODEL NO. : TSUP-4B	DRAWING NO. :	REV : A	PAGE 1 / 7	 NIPPON CERAMIC CO., LTD.
PART NO. :				

1. SCOPE

This specification describes a Thermopile Infrared Sensor Unit for non-contact temperature measurement supplied by Nippon Ceramic Co., Ltd.

2. TYPE of UNIT

2.1. TYPE NAME

Thermopile Infrared Sensor Unit

2.2. MODEL NO.

TSUP-4B

3. DIMENSIONS

See Fig. 1.

Production Lot No. is put on a Unit.

4. GENERAL CHARACTERISTICS

Table 1

PARAMETER	SPECIFICATION
4.1. Thermopile Sensor	Single type Thermopile
4.2. Optics	Silicon-Lens(uncoated)
4.3. Time Constant	Typ. 50 msec. (+/-) 50 %
4.4. Circuit Configuration	See Fig. 2
4.5. Detection Area	See Fig. 3
4.6. Directivity	See Fig. 4
4.7. Detecting Temperature Range	20 ~ 60 degrees Celsius
4.8. Accuracy	Within (+/-) 0.5 degrees Celsius
4.9. Operating Temperature	0 ~ 60 degrees Celsius
4.10. Storage Temperature	-20 ~ 100 degrees Celsius

5. ELECTRICAL CHARACTERISTICS

Table 2

PARAMETER	CONDITION	SPECIFICATION
5.1. Thermopile Signal Output	Object Temp. : 35 degrees Celsius (Emissivity = 0.99) Ambient Temp. : 25 degrees Celsius Distance : 100 mm	3.010 V (+/-) 3 %
5.2. Temperature Characteristics of Thermopile Signal Output	Object Temp. : 20 ~ 60 degrees Celsius (Supply Voltage:5V)	See Data 1
5.3. Supply Voltage	Single Power Supply	5 ~ 16 V (Maximum Rating : 18 V)
5.4. Current Consumption	+Vs = 5 V Supply	Max. 5 mA
5.5. Output Current	Short Circuit to Ground	Max. 60 mA

6. MEASUREMENT METHOD

6.1. Thermopile Signal Output

See Fig. 5.

MODEL NO. : TSUP-4B	DRAWING NO. :	REV : A	PAGE 2 / 7	 NIPPON CERAMIC CO., LTD.
PART NO. :				

7. NOTES

7.1. Design restrictions/precautions

For outdoor applications, be sure to apply suitable supplementary optical filter, drip-proof and anti-dew construction. This Unit is designed for indoor use.

In cases where secondary accidents due to operation failure or malfunctions can be anticipated, add a fail safe function to the design.

7.2. Usage restrictions/precautions

To prevent Unit malfunctions, operational failure or any deterioration of its characteristics, do not use this Unit in the following, or similar, conditions.

7.2.1 In rapid environmental temperature changes.

7.2.2 In strong shock or vibration.

7.2.3 In a place where there are obstructing materials (Glass, Fog, etc.) through which infrared rays cannot pass within detection area.

7.2.4 In fluid, corrosive gases and sea breeze.

7.2.5 Continual use in high humidity atmosphere.

7.2.6 In field of static electricity or strong electromagnetic waves.

7.2.7 Exposed to direct wind from a heater or air conditioner.

7.3. Handling and storage restrictions/precautions

To prevent Unit malfunctions, operational failure, appearance damage or any deterioration of its characteristics, do not expose this Unit to the following or similar, handling and storage conditions.

7.3.1. Vibration for a long time.

7.3.2. Strong shock.

7.3.3. Static electricity or strong electromagnetic waves.

7.3.4. High or Low temperature and humidity for a long time.

7.3.5. Corrosive gases or sea breeze.

7.3.6. Dirty and dusty environments that may contaminate the optical window.

Unit troubles resulting from misuse, inappropriate handling or storage are not the manufacturer's responsibility.

MODEL NO. : TSUP-4B	DRAWING NO. :	REV : A	PAGE 3 / 7	 NIPPON CERAMIC CO., LTD.
PART NO. :				

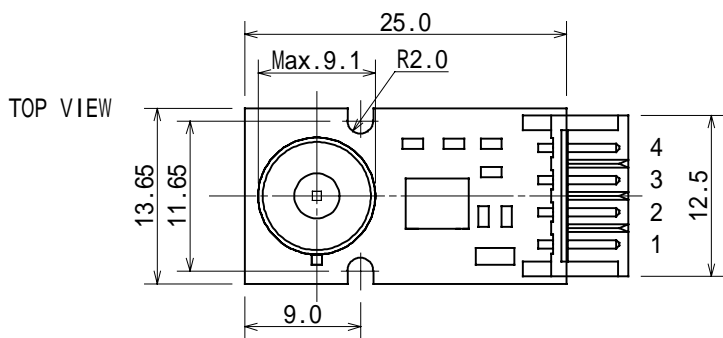

Pin Arrangement

- 4 : Vout
- 3 : Ground
- 2 : +Vs
- 1 : Vntc(Thermistor Signal Output)

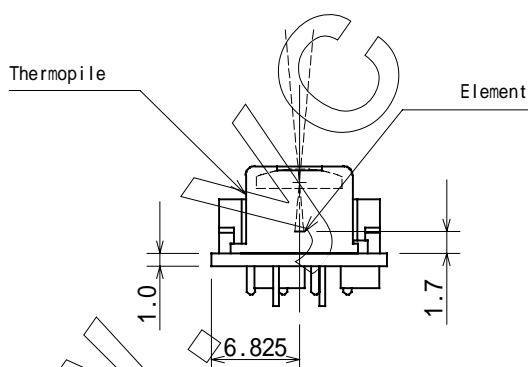
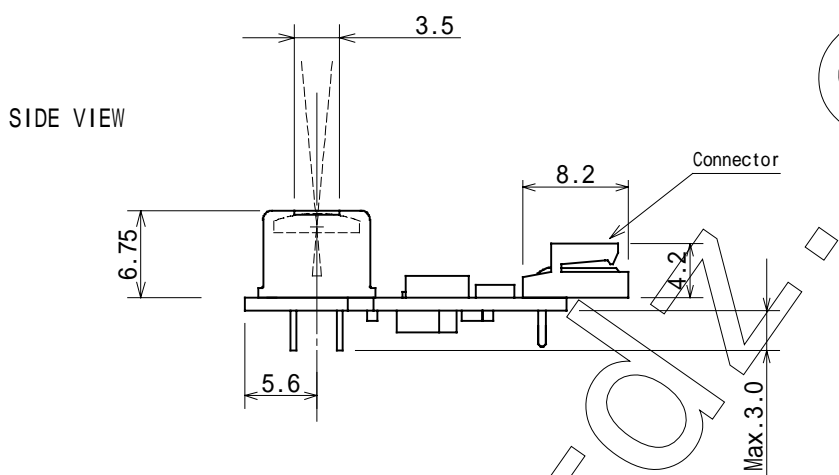

Tolerance : ± 0.2

unit [mm]

Fig. 1 : Dimensions

MODEL NO. : TSUP-4B	DRAWING NO. :	REV : A	PAGE 4 / 7	
PART NO. :				

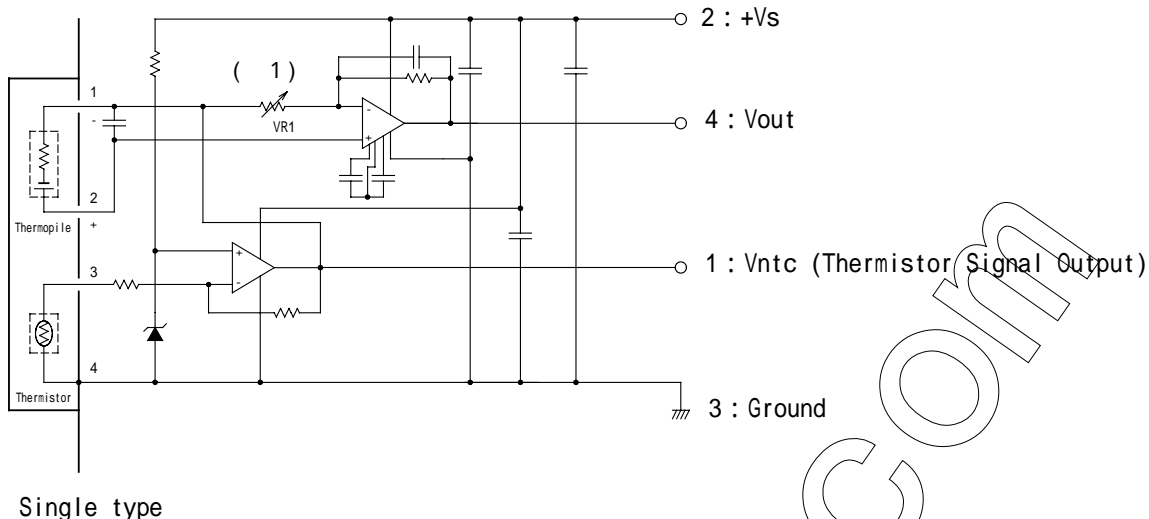

(*1) Thermopile Signal Output of Unit is calibrated by VR1 at outgoing inspection, Do not touch VR1.

Fig. 2 : Circuit Configuration

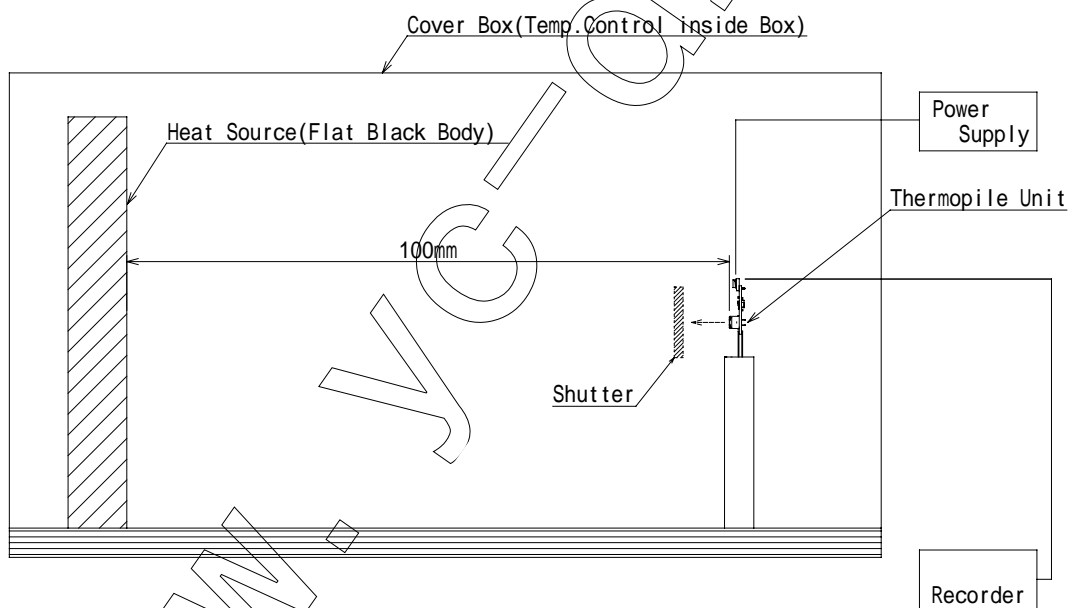

Heat Source Temp.: 35
 Distance : 100 mm
 Supply Voltage : 5 V

* Thermopile Signal Output Shutter On/Off
 Shutter On(Open) : Infrared Incidence
 Shutter Off(Close) : Infrared Cut-off

Fig. 5 : Test Set-up Block Diagram

MODEL NO. : TSUP-4B	DRAWING NO. :	REV : A	PAGE 5 / 7	NIPPON CERAMIC CO., LTD.
PART NO. :				

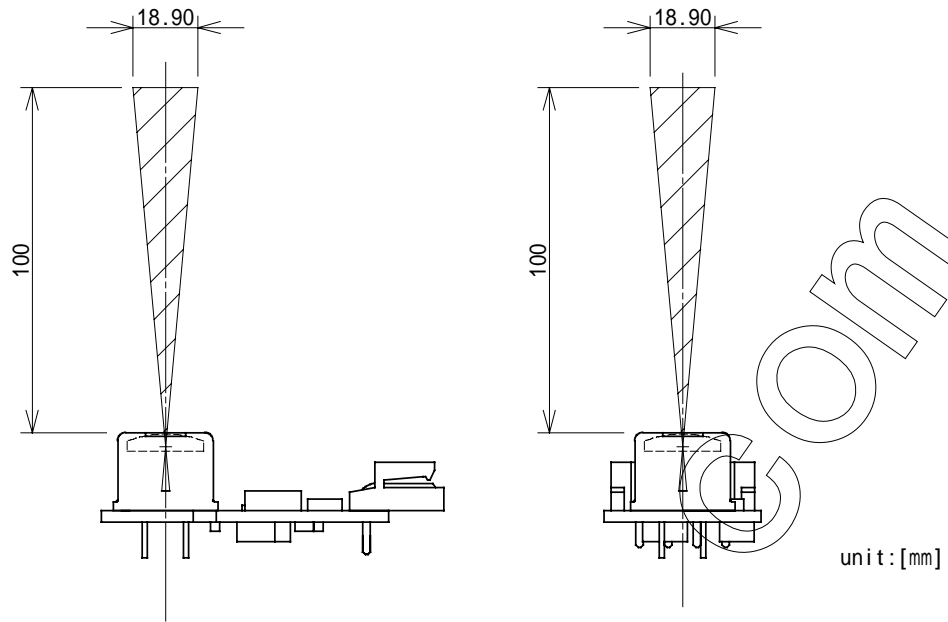
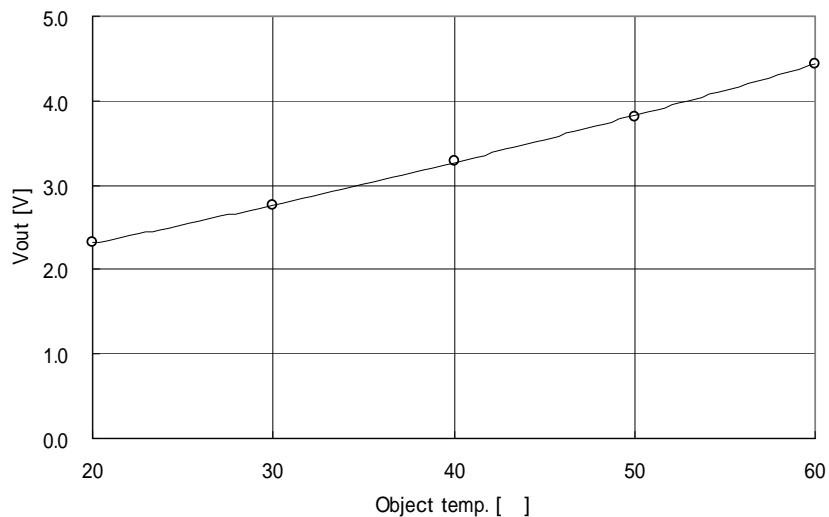

Fig. 3 : Detection Area



Fig. 4 : Directivity

MODEL NO. : TSUP-4B	DRAWING NO. :	REV : A	PAGE 6 / 7	NIPPON CERAMIC CO., LTD.
PART NO. :				



Object temp. [°C]	20	30	40	50	60	Data
Vout [V]	2.312	2.759	3.292	3.799	4.442	- -

* Distance : 100 mm

Data 1 : Temperature Characteristics of Thermopile Signal Output

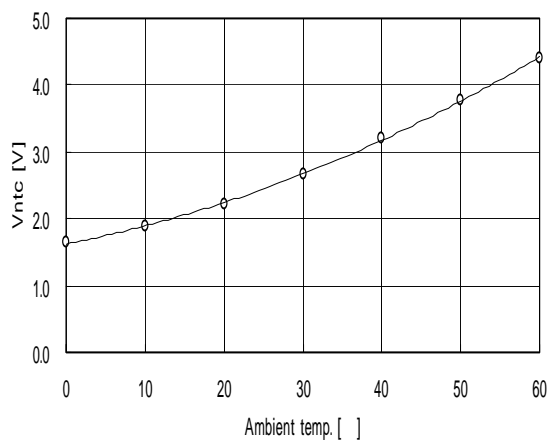

Thermistor

Resistance: Typ. R = 100kohm (at 25 [degrees Celsius])

Beta value: 3955K (+/-) 0.5 % (T1/T2: 0/50 [degrees Celsius])

Ambient temp. [°C]	0	10	20	30	40	50	60	Data
Vntc [V]	1.640	1.883	2.223	2.661	3.196	3.786	4.402	- -

Data 2 : Temperature Characteristics of Thermistor Signal Output

MODEL NO. : TSUP-4B	DRAWING NO. :	REV : A	PAGE 7 / 7	
PART NO. :				