

## Request For Quotation

Order the parts you need from our real-time inventory database. Simply complete a request for quotation form with your part information and a sales representative will respond to you with price and availability.

[Request For Quotation](#)

**Your free datasheet starts on the next page.**

More datasheets and data books are available from our homepage: <http://www.datasheetarchive.com>

# HFM1222

## Token Ring Receiver

### FEATURES

- -31 dBm to -11 dBm sensitivity
- Differential data outputs (ECL compatible)
- Signal Quality Detect output (open collector)
- Output squelch input (TTL)
- Adjustable signal quality detect level
- ST® interface
- 500 Ω output drive capability
- Monolithic design - less board space, high reliability
- 4 and 16 Mbps operation



FIBER101.TIF

### DESCRIPTION

The HFM1222 Token Ring fiber optic receiver module is designed for use in computer LAN (16 Mb/s Token Ring) applications. The 9 pin module is intended to meet IEEE 802.5J signal standards.

A PIN photodiode plus pre-amp is mounted in the fiber optic connector for maximum shielding, and provides amplification and current-to-voltage conversion. The post-amp IC provides final amplification to the logic output levels (see Block Diagram).

Differential Data, Signal Quality Detect output, and Output Squelch input are available. Differential ECL output allows capacitive coupling to ECL logic and other differential line receivers. The HFM1222 has a 500 ohm output drive capability. An internally regulated power supply increases power supply rejection. Case ground is separated from circuit ground, allowing feedthrough mounting of the barrel.

### APPLICATION

Average-to-peak input level monitoring generates the signal quality detect signal ( $\overline{SQ}$ ) when the input level is adequate for  $10^{-10}$  BER. The open collector output timing response of  $\overline{SQ}$  is intended to meet 802.5J requirements over -31 dBm to -11 dBm average power levels. Note that the differential outputs are true with the light "on".

### OUTLINE DIMENSIONS in inches (mm)

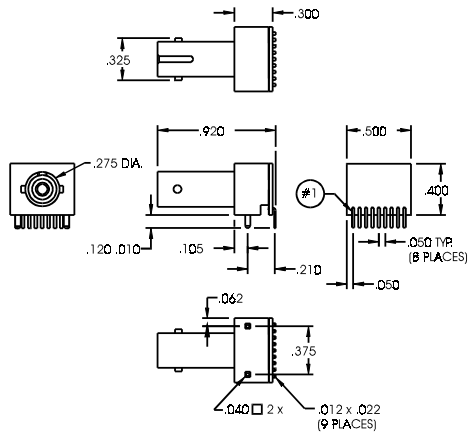

ODIM\_204.cdr

### Pinout

- |                    |                    |
|--------------------|--------------------|
| 1. GND ground      | 6. Squelch         |
| 2. V <sub>cc</sub> | 7. Not connected   |
| 3. Output +        | 8. ADJ             |
| 4. Output -        | 9. $\overline{SQ}$ |
| 5. O GND           |                    |

# HFM1222

## Token Ring Receiver

---

### APPLICATION (continued)

SQUELCH input is a TTL logic level. When it is high, it will disable the data outputs to prevent noise on the ECL outputs. With SQUELCH high, the outputs go to the same state as Light On at the input. It can be connected directly to the  $\overline{SQ}$  output to squelch the outputs under low light conditions (receiver noise would cause unwanted chatter).

Resistor  $R_{ADJ}$  adjusts the  $\overline{SQ}$  threshold upward. A resistor applied from ADJ to ground can be used to adjust the receiver's  $\overline{SQ}$  threshold upward by 0 to 3.2 dB (optically). The ratio increase in threshold is given by:  $(R_{ADJ} + 24.3K)/(R_{ADJ} + 11.6K)$ .

ST is a registered trademark of AT & T.

# HFM1222

## Token Ring Receiver

### ELECTRO-OPTICAL CHARACTERISTICS (Over 0 to 70°C, V<sub>CC</sub> = 4.75 to 5.25 VDC unless otherwise stated)

PARAMETER	SYMBOL	MIN	TYP	MAX	UNITS	TEST CONDITIONS
Data Rate (operating range)		4		16	MBPS	Manchester coding
Input Power (operating range)		-31		-11	dBm	Average power (10 <sup>-10</sup> BER) 850 nm
Supply Current			21	35	mA	Excluding S <sub>Q</sub>
Jitter (uncorrelated) <sup>(1)</sup> <sup>(2)</sup>				0.55	ns	RMS, -31 dBm average input
Pulse Width Distortion <sup>(1)</sup> <sup>(2)</sup>				6	ns	Average; -11 dBm input
Signal Quality Detect (S <sub>Q</sub> )			-34	-31	dBm	Threshold for S <sub>Q</sub> , high to low
Delay Time (acceptable level) <sup>(3)</sup>			13	18	μs	P <sub>IN</sub> > -31 dBm average
Delay Time (unacceptable level) <sup>(3)</sup>			4.5	7	μs	P <sub>IN</sub> < -11 dBm average
Output (Out+/Out-) Load		500			Ω	
Output Swing		1.6	2.3		V	Peak to peak (differential) 25°C
S <sub>Q</sub> V <sub>OL</sub>				+1000	ppm/°C	Over temperature
Receiver Bandwidth			44		MHz	Small signal
Signal Quality Detect (S <sub>Q</sub> ) <sup>(4)</sup> <sup>(5)</sup>		-38			dBm	Transition for S <sub>Q</sub> low to high
Signal Quality Detect, Hysteresis		0.3	1.5		dB	For low to high transition
Output Rise and Fall Time <sup>(6)</sup>				3.3	ns	-31 dBm input
Squelch Input		2			V	V <sub>IH</sub>
				0.8	V	V <sub>IL</sub>
			0.16		mA	I <sub>IL</sub>
Power Supply Rejection <sup>(7)</sup>			100		mV(pk-pk)	At 16 MHz

#### Notes

1. Measured with 50% level of output with a 16 MHz, 50% duty cycle square wave input.
2. Measured with an input optical rise/fall time less than 6 ns.
3. Measured with a 16 MHz square wave input switched between light on and light off with a 60 μsec period in each state.
4. The S<sub>Q</sub> line will be high for any input power at this or lower input powers.
5. The BER will be 0.01 or better.
6. Load at each output is 500 Ω in parallel with 5 pf to AC ground.
7. Maximum power supply noise at 16 MHz to keep BER < 10<sup>-10</sup> at 31 dBm.

#### ABSOLUTE MAXIMUM RATINGS

Supply voltage (V <sub>CC</sub> )	< 7.0 V
Temperature	-40 to +85°C

Stresses greater than those listed under "Absolute Maximum Ratings" may cause permanent damage to the device. This is a stress rating only and functional operation of the device at these or any other conditions above those indicated in the operational section of this specification is not implied. Exposure to absolute maximum rating conditions for extended periods of time may affect reliability.

#### RECOMMENDED OPERATING CONDITIONS

Supply voltage (V <sub>CC</sub> )	4.75 to 5.25 V
Temperature	0 to +70°C

#### ORDER GUIDE

Description	Catalog Listing
Fiber Optic Token Ring receiver, 9 pin Package	HFM1222-331

#### CAUTION

The inherent design of this component causes it to be sensitive to electrostatic discharge (ESD). To prevent ESD-induced damage and/or degradation to equipment, take normal ESD precautions when handling this product.



# HFM1222

## Token Ring Receiver

### FIBER INTERFACE

Honeywell receivers are designed to interface with multimode fibers (50/125 to 200/230 micron diameter). Final testing is performed with a 62.5/125 micron core fiber. Low cost 50/125 and 62.5/125 micron fibers are good for high bandwidth applications. 100/140 and 200/230 micron fibers result in greater power coupling by the transmitter, making it easier to splice or connect in bulkhead areas.

### TYPICAL CIRCUIT CONFIGURATION

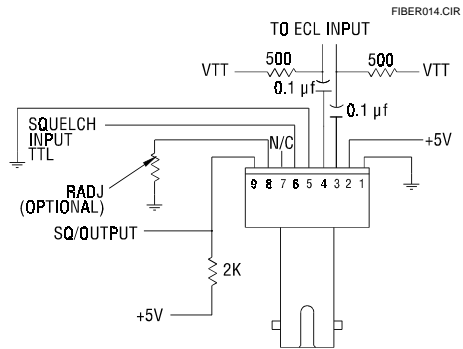

### BLOCK DIAGRAM

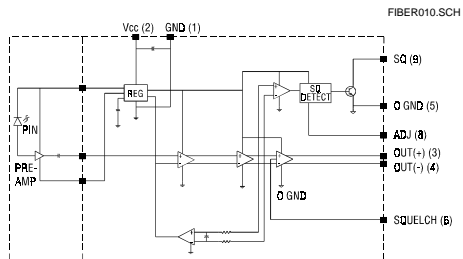
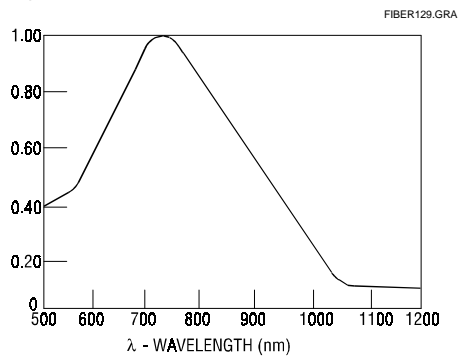

Fig. 1 Spectral Responsivity



Honeywell reserves the right to make changes in order to improve design and supply the best products possible.

**Honeywell**