

REFERENCE

Product name : OPTICAL DATA COMMUNICATION TRANSCEIVER

Model No. : GP2W3240YP

1. These specification sheets include materials protected under copyright of Sharp Corporation ("Sharp"). Please do not reproduce or cause anyone to reproduce them without Sharp's consent.
2. When using this product, please observe the absolute maximum ratings and the instructions for use outlined in these specification sheets, as well as the precautions mentioned below. Sharp assumes no responsibility for any damage resulting from use of the product which does not comply with the absolute maximum ratings and the instructions included in these specification sheets, and the precautions mentioned below.

(Precautions)

- (1) This product is designed for use in the following application areas ;

(· OA equipment Audio visual equipment · Home appliances
· Telecommunication equipment (Terminal) · Measuring equipment
· Tooling machines · Computers)

If the use of the product in the above application areas is for equipment listed in paragraphs (2) or (3), please be sure to observe the precautions given in those respective paragraphs.

- (2) Appropriate measures, such as fail-safe design and redundant design considering the safety design of the overall system and equipment, should be taken to ensure reliability and safety when this product is used for equipment which demands high reliability and safety in function and precision, such as ;

(· Transportation control and safety equipment (aircraft, train, automobile etc.)
· Traffic signals · Gas leakage sensor breakers · Rescue and security equipment
· Other safety equipment)

- (3) Please do not use this product for equipment which require extremely high reliability and safety in function and precision, such as ;

(· Space equipment · Telecommunication equipment (for trunk lines)
· Nuclear power control equipment · Medical equipment)

- (4) Please contact and consult with a Sharp sales representative if there are any questions regarding interpretation of the above three paragraphs.

3. Please contact and consult with a Sharp sales representative for any questions about this product.

REFERENCE

1. Application
This specification applies to the outline and characteristics of IrDA1.2 type (Data rate 2.4kbps to 115.2kbps, Low Power Option compliant) Optical Data communication transceiver, Model No. GP2W3240YP.
2. Outline
Refer to the attached drawing No. CY12047i02, page 6.
3. Ratings and characteristics
Refer to the attached sheet, page 8 to 10.
4. Reliability
Refer to the attached sheet, page 11.
5. Outgoing inspection
Refer to the attached sheet, page 12.
6. Supplements
 - 1) This optical data communication transceiver is satisfied with each characteristics of item 3.3, in the optical system shown in 3, 5.
 - 2) This product is built-in photodiode.
 - 3) This device confirms eye safety IEC60825-1 class 1, and also without external resistor.
 - 4) This product shall not contain the following materials.
Also, the following materials shall not be used in the production process for this product.
Materials for ODS : CFCs, Halon, Carbon tetrachloride, 1.1.1-Trichloroethane (Methylchloroform)
Specific brominated flame retardants (PBBOs, PBBs)
 - 5) This product is Pb free.
 - 6) Product mass : Approx. 0.08g
 - 7) Package specifications : Refer to the attached sheet, page 14 to 18.
7. Notes
 - 1) If the surface of detector is smeared with dust or dirt, it may cause faulty operation. Caution shall be taken to avoid this.
And do not touch the detector surface.
 - 2) Cleaning conditions :
Solvent cleaning : Solvent temperature 45 or less, Immersion for 3 min or less
Ultrasonic cleaning : The effect to device by ultrasonic cleaning differs by cleaning bath size, ultrasonic power output, cleaning time, PCB size or device mounting condition etc. Please test it in actual using condition and confirm that doesn't occur any defect before starting the ultrasonic cleaning.
The cleaning shall be carried out with solvent below.
Solvent : Ethyl alcohol, Methyl alcohol, Isopropyl alcohol
 - 3) In order to prevent electrostatic discharge of integrated circuit, human body and soldering iron, etc. shall be grounded.
 - 4) In case that things touch to the device after mounting, such external force is applied to the device, there is possibility to be caused the mounting defect such as terminal coming off. Please be careful for handling.
 - 5) **Don't do wiring in the territory where a mounting side touches the back of the product** except for the product terminal part.
 - 6) Precautions for Soldering
Refer to the attached, page 13.

REFERENCE

- 7) When the system (program) is designed, the Turn Around Time shall be designed by considering 500 μs or more that is specified by IrDA. Then, this Turn Around Time means the time when this device does not temporarily defect the signal light, since the transmitted light from the transceiver reaches the detector side of the same transceiver.
- 8) As it is necessary 200 μs or more (at Ta=25 °C, no input signal) to return from shut-down mode to ready-operation mode, please consider this point at the system (program) designing. Also, please confirm thoroughly the operation in accrual application.
- 9) When there is much external disturbing light or the light source is located near this transceiver and the detector face receives much external disturbing light, there is a case that the pulse other than signal output is generated as noise on output terminal of this transceiver. Please consider the lay-out and structure to reduce disturbing light on the detector face.
- 10) In case that this sensor is adopted in IR communication system, please use it according to the signal method which is specified by 『Serial Infrared Physical Layer Link Specification Version 1.4』 published by the Infrared Data Association. Faulty operation may happen, if different signal method than specified one is used.
- 11) RXD pin out remains at High level output (pull up output) in shutdown mode.
- 12) In circuit designing, make allowance for the degradation of the light emitting diode output that results from long continuous operation. (50% degradation/ 5 years)
- 13) Recommended external circuit

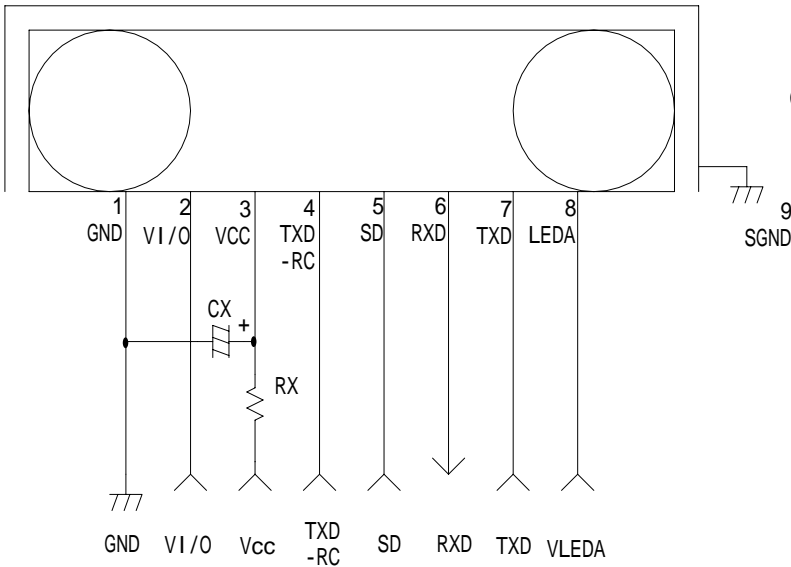

Components	Recommended values
CX	1 μF/ 6.3V (Note)

(Note) Please choose the most suitable CX according to the noise level and noise frequency of power supply. Depend on noise level and noise frequency of power supply, CX does not work well. There are cases that some pulse noises from RXD other than signal will occur in certain communication area. Please check by finish product that there are no problem at all communication area and data rate. If there are any problem, please check by inserting RX (1 to 15 Ω) in the circuit drawing.

* I/O Logic table

S D	TXD	LED	Receiver	TR1	TR2	RXD
Low	High	on	Don't Care	-	-	Not Valid
	Low	off	IrDA Signal	off	on	Low
			No Signal	on	off	High
High	Don't Care	off	Don't Care	off	off	pull-up

* RXD Equipment circuit

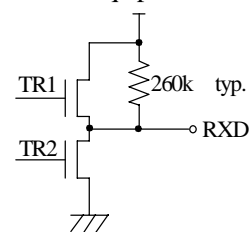

REFERENCE

14) Example of system

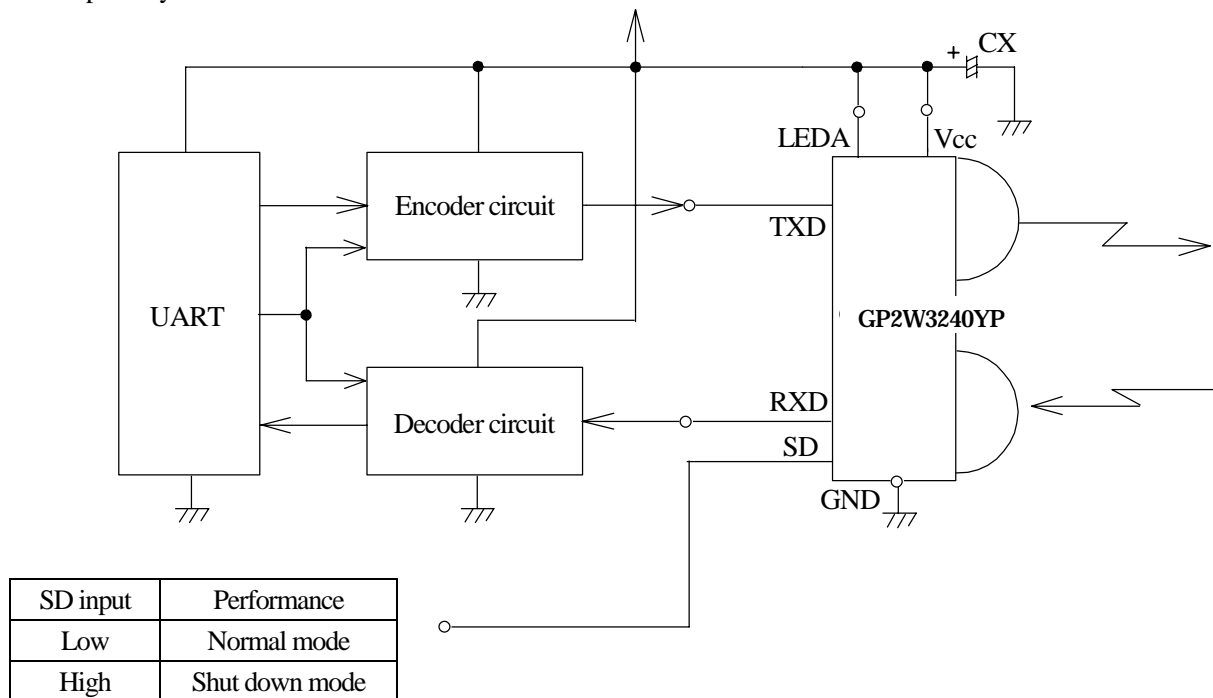

15) Example of signal waveform

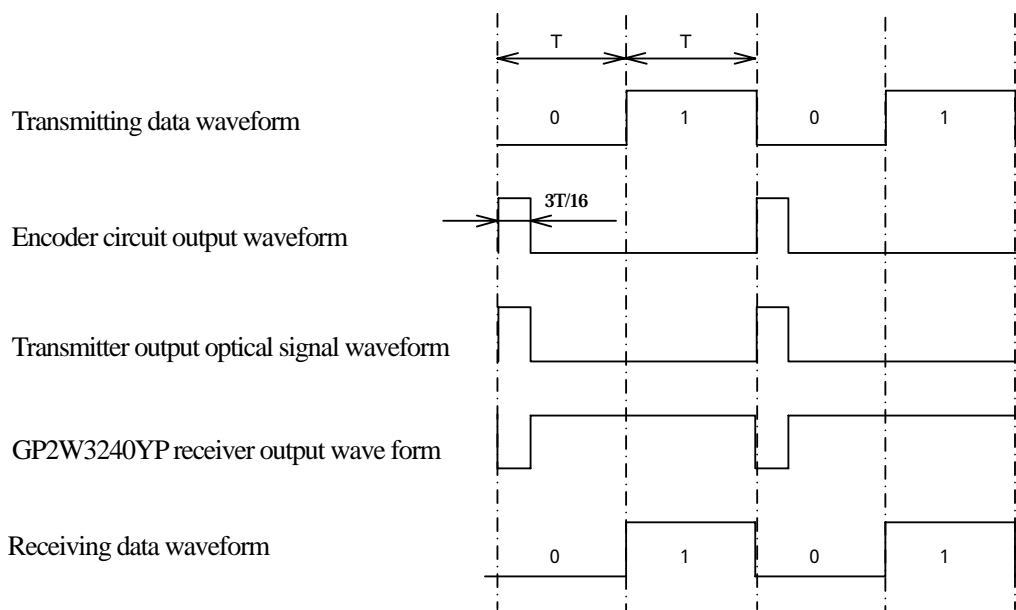

$$T = \frac{1}{\text{Data rate}}$$

- Data rate : 2.4kbps, 9.6kbps
 19.2kbps, 38.4kbps
 57.6kbps, 115.2kbps

REFERENCE

16) Foot pattern of PCB

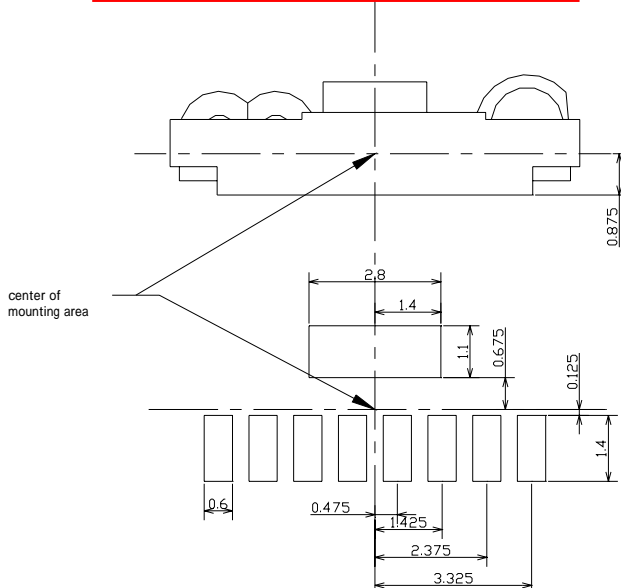

(1) Dimension are shown for reference.

(2) Unit : mm

[Terminal arrangement]

	Ground	GND
	VI/O	VI/O
	V _{CC}	V _{CC}
	TXD for Remote Control	TXD-RC
	Shutdown	SD
	Receiver Data Output	RXD
	Transmitter Data Input	TXD
	LED Anode	LEDA

* Connect foot pattern of shield case to GND pattern.

17) Recommendable size of solder creamed paste (Reference)

Please open the solder mask as below so that the size of solder creamed paste for this device before reflow soldering must be as large as one of the foot pattern land indicated at 16).

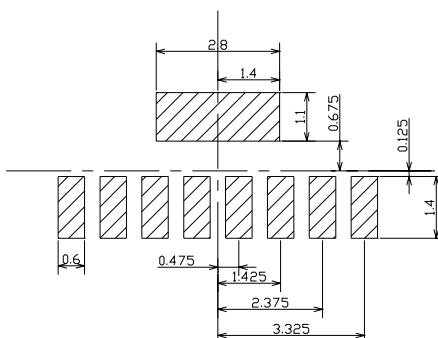

Soldering paste area

Dimension are shown for reference.

Unit : mm

REFERENCE

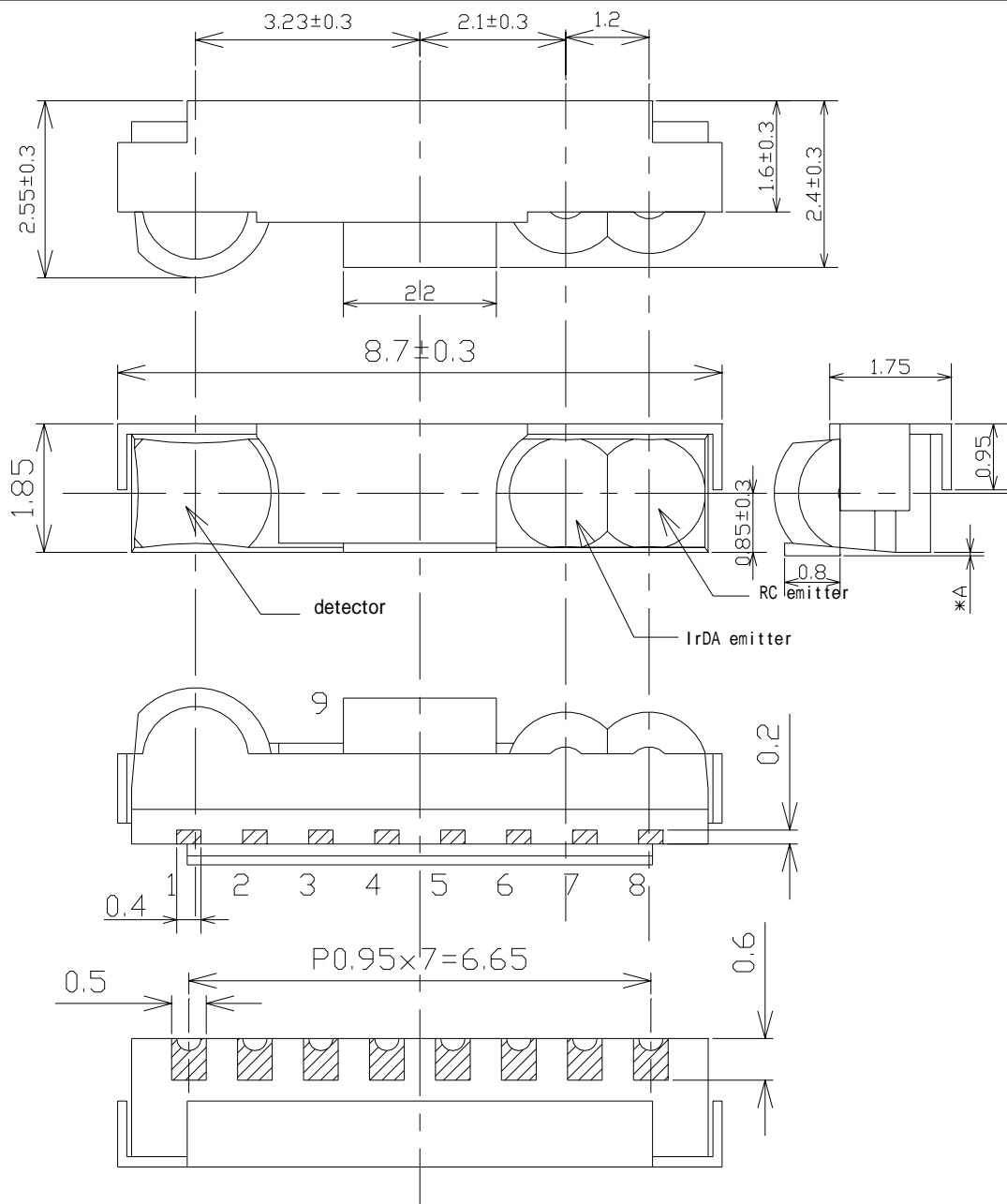

*A : Distance between PCB of the transceiver and bottom side of shield case shall be +/-0.1mm.

Pin	Pin name	Symbol
	Ground	GND
	V/I/O	VI/O
	V _{CC}	V _{CC}
	TXD for Remote Control	TXD-RC
	Shutdown	SD
	Receiver Data Output	RXD
	Transmitter Data Input	TXD
	LED Anode	LEDA
	Shield Ground	SGND

- 1) area : Au plating
- 2) Unspecified tolerance shall be ± 0.2.

Name	GP2W3240YP Outline Dimensions
Scale	Unit
10/1	1=1/1mm
Drawing No.	CY12047i02

REFERENCE

3. Ratings and characteristics

3.1 Absolute maximum ratings

Parameter	Symbol	Ratings	Unit	Remark
Supply voltage	V _{CC}	0 to 6.0	V	
VI/O Supply voltage	V _{IO}	0 to V _{CC}	V	
LED Supply voltage	V _{LEDA}	0 to 7.0	V	
SD, TXD input voltage	V _{SD} , V _{TXD}	-0.3 to V _{IO} +0.3	V	
TXD-RC input voltage	V _{TXDRC}	-0.3 to V _{CC} +0.3	V	
Peak forward current 1	I _{FM1}	120	mA	Pulse width : 78.1 μs, Duty ratio : 3/16
Peak forward current 2	I _{FM2}	300	mA	Pulse width : 17.9 μs, Duty ratio : 1/4
Operating temperature	Topr	-40 to +85		
Storage temperature	Tstg	-40 to +100		
Soldering temperature	Tsol	260		Soldering reflow time : 10s

3.2 Recommended operating conditions

Parameter	Symbol	Operating condition	Unit	Remark
Supply voltage	V _{CC}	2.4 to 3.6	V	
VIO Supply voltage	V _{IO}	1.5 to V _{CC}	V	
LED Supply voltage	V _{LEDA}	V _{CC} -0.5 to 6.5	V	
Operating temperature	Topr	-25 to +85		
Data rate	BR	2.4 to 115.2	kbps	
SD terminal input voltage Logic High	V _{IHSD}	V _{IO} × 0.67 to V _{IO}	V	Shut down mode
SD terminal input voltage Logic Low	V _{ILSD}	0.0 to V _{IO} × 0.33	V	Normal mode
TXD high level input voltage	V _{IHTXD}	V _{IO} × 0.67 to V _{IO}	V	LED ON 6
TXD low level input voltage	V _{ILTXD}	0.0 to V _{IO} × 0.33	V	LED OFF 6
TXD-RC high level input voltage	V _{IHTXDRC}	V _{IO} × 0.67 to V _{CC}	V	LED ON 6
TXD-RC low level input voltage	V _{ILTXDRC}	0.0 to V _{IO} × 0.33	V	LED OFF 6

REFERENCE

3.3 Electrical characteristics

(Topr = 25 , Vcc = VIO = 3.3V Unless otherwise specified)

Parameter	Symbol	MIN.	TYP.	MAX.	Unit	Remark	
Current consumption at no input signal	I _{cc}	-	90	120	μA	No input signal, V _{IHSD} =0V, Output terminal OPEN	
Current consumption at Shut-down mode	I _{cc-s}	-	0.001	0.1	μA	No input signal, V _{IHSD} =VIO Output terminal OPEN	
High level output voltage	V _{OH}	VIO-0.4	-	-	V	I _{OH} =-200 μA, V _{CC} =2.4 to 3.6V 1, 2, 3	
Low level output voltage	V _{OL}	-	-	0.4	V	I _{OL} =200 μA, V _{CC} =2.4 to 3.6V 1, 2, 3	
Rise time	t _r	-	-	0.06	μs	BR=115.2kbps, C _L =10pF, 1, 2, 3	
Fall time	t _f	-	-	0.06	μs		
Low level pulse width	t _w	1.35	2.25	3.3	μs		
Maximum reception distance	L	21	-	-	cm	BR=115.2kbps, 15° 1, 2, 3	
Input irradiance	E _e		-	0.081	W/m ²		
Receiver Latency	t _l	-	-	200	μs		
Receiver wakeup time	t _{sdw}	-	-	200	μs	No input signal	
I r D A	Radiant intensity	I _E	7.0	-	28	mW/sr	BR=115.2kbps, 15°, V _{IHTXD} =2.8V 4, 5, 6
	LED peak current	I _{LED}	45	65	100	mA	
	Rise time	t _r	-	-	0.6	μs	
	Fall time	t _f	-	-	0.6	μs	
	Peak emission wavelength	p	850	870	900	nm	
	Maximum optical pulse width	t _{OPWM}	30	80	250	μs	TXD pin stuck high
R C	Transmitt distance	L _{RC}	4	-	-	m	f = 40kHz, duty=25%, =0°, V _{IHTXD} =2.8V 4, 5, 6
	Radiant intensity	I _{ERC}	24	-	-	mW/sr	
	LED peak current	I _{LEDRC}	125	175	225	mA	
	Peak emission wavelength	p	-	940	0	nm	
	Maximum optical pulse width	t _{OPWM}	30	80	250	μs	TXD pin stuck high

REFERENCE

1 Input signal waveform (Detector side)

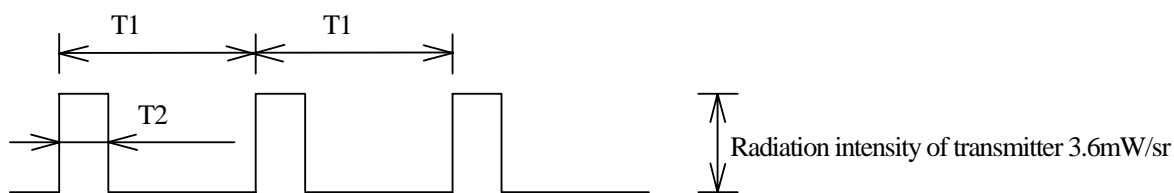

At BR= 2.4kbps : T1=416.7 μs, T2=78.1 μs

At BR=115.2kbps : T1=8.68 μs, T2=1.63 μs

2 Output waveform specification (Detector side)

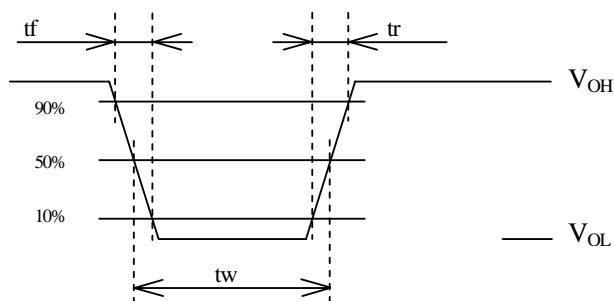

3 Standard optical system (Detector side)

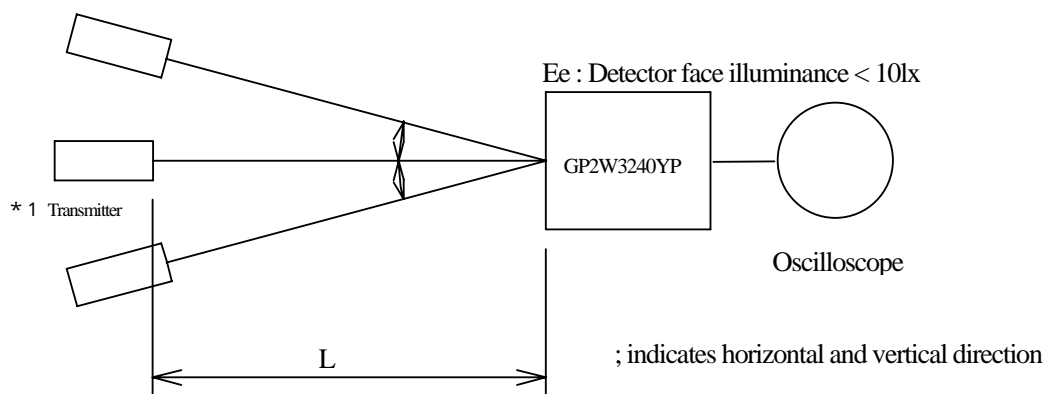

*1 Transmitter shall use GP2W3240YP (λ=870nm TYP.) which is adjusted the radiation intensity at 3.6mW/sr.

REFERENCE

4 Output waveform specification (Emitter side)

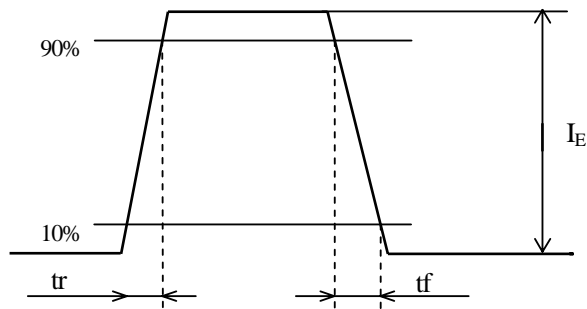

5 Standard optical system (Emitter side)

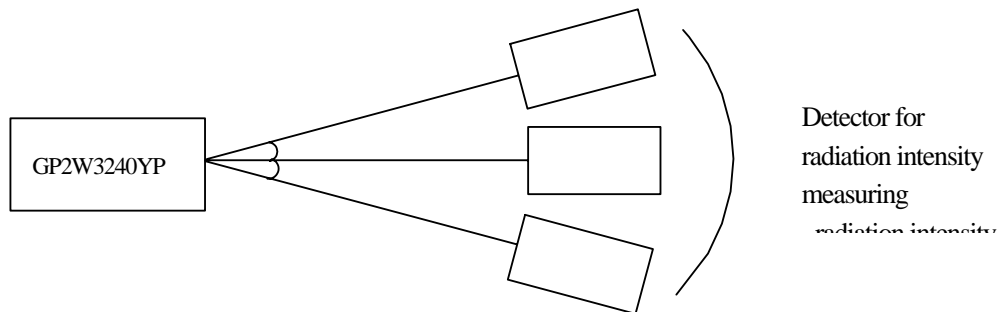

: indicates horizontal and vertical directions

6 Recommended circuit (Emitter side)

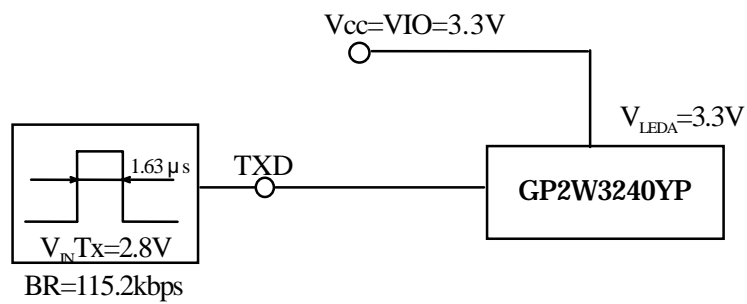

REFERENCE

4. Reliability

The reliability of products shall satisfy items listed below.

Confidence level : 90%

LTPD : 10 or 20

Test Items	Test Conditions	Failure Judgement Criteria	Samples (n)
			Defective(C)
* Temperature cycling	1 cycle -40 to +100 (30min) (30min) 20 cycles test	$I_{CC} > U_p \times 1.2$ $L < Low \times 0.8$ $I_E < Low \times 0.8$ $I_E > U_p \times 1.2$ U : Upper specification limit L : Lower specification limit	n=22, c=0
* High temp. and high humidity storage	+40 , 90%RH, 240h		n=22, c=0
* High temp. storage	+100 , 240h		n=22, c=0
* Low temp. storage	-40 , 240h		n=22, c=0
* Operation life	+25 , $V_{CC}=LEDA=3.3V$, 240h Pulse width 78.1 μs , Duty ratio 3/16		n=11, c=0
Mechanical shock	1000m/s ² , 6ms 3 times/ $\pm X$, $\pm Y$, $\pm Z$ direction		n=11, c=0
Variable frequency vibration	200m/s ² , 100 to 2000 to 100Hz/ Approx. for 4min, 48min/ X, Y, Z direction		n=11, C=0
Reflow solder heat	260 , 10s, 2times Regarding temperature profile, Refer to attached soldering notes.	n=11, c=0	

In the test *mark above, the sample to be tested shall be left at normal temperature and humidity for 2h after it is taken out of the chamber. (No dew point)

REFERENCE

5. Outgoing inspection

(1) Inspection lot

Inspection shall be carried out per each delivery lot.

(2) Inspection method

A single sampling plan, normal inspection level based on ISO 2859 shall be adopted.

Parameter	Inspection items and test method		AQL(%)	
Major defect	1	Disconnection, short	0.1	
	2	Inverse polarity on terminal		
	3	Soldering defect		
	4	Electrical characteristic defect in parameter 3.3.		
Minor defect	1	Appearance defect	0.25	
		Parameter		Judgement criteria
		Split, Chip, Scratch, Stain, Blur		One which affects the characteristics of parameter 3.3 shall be defect.

REFERENCE

Precautions for Soldering

1. In case of solder reflow

Please carry out only two times soldering at the temperature and the time within the temperature profile as shown in the figure below. Reflow interval shall be within 3 days under conditions, 10 to 30 °C, 70%RH or less.

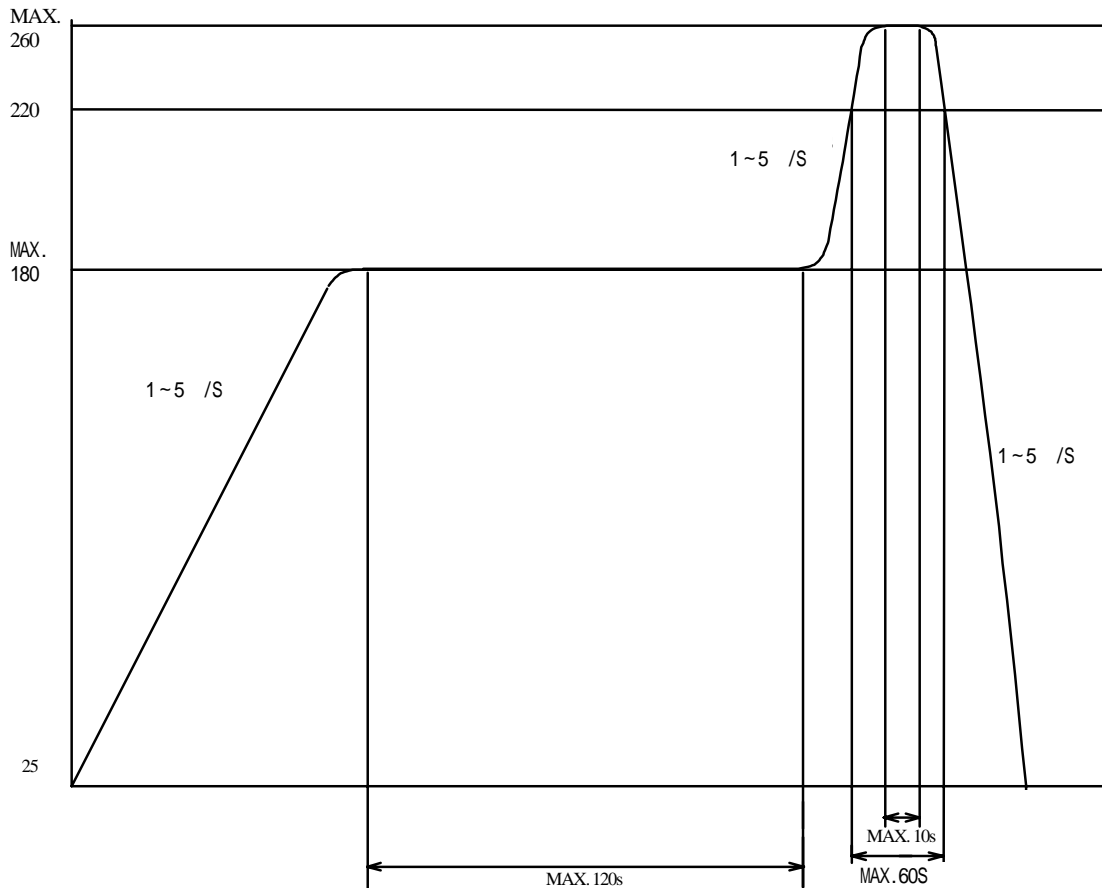

2. Other precautions

An infrared lamp used to heat up for soldering may cause a localized temperature rise in the resin.

So keep the package temperature within that specified in Item 1. Also avoid immersing the resin part in the solder.

Even if within the temperature profile above, there is the possibility that the gold wire in package is broken

in case that the deformation of PCB gives the affection to lead pins. Please use after confirmation the conditions fully by actual solder reflow machine.

3. Soldering

- Soldering iron shall be less than 25W, and temperature of point of soldering iron shall use at less than 380 °C.
- Soldering time shall be within 5s.
- Soldered product shall treat at normal temperature.

Taping specifications

1. Application

This packing specification sheets specify the taping specifications for GP2W3240YP.

2. Taping method

2-1. Taping material

Name	Material	Counter measure for ESD
Reel	PPE	Conductive type
Carrier tape	PC	Conductive type
Cover tape	PET	Conductive type

2-2. Tape structure and Dimensions (Refer to the attached sheet, page 16.)

The tape shall have a structure in which a cover tape is sealed heat-pressed on the carrier tape of conductive PET.

2-3. Reel structure and Dimensions (Refer to the attached sheet, page 17.)

The taping reel shall be conductive plastic with its dimensions as shown in the attached drawing.

2-4. Direction of product insertion (Refer to the attached sheet, page 17.)

Product direction in carrier tape shall be that lens side of product places on the pull-out side of the tape and electrode side of product places on the hold side of the tape.

2-5. The way to repair taped failure devices

The way to repair taped failure devices cut a bottom of carrier tape with a cutter, and after replacing to good devices, the cutting portion shall be sealed with adhesive tape. In this case, device will not be refilled.

3. Adhesiveness of cover tape

The exfoliation force between carrier tape and cover tape shall be 0.2N to 1N for the angle from 160 ° to 180 ° .

4. Rolling method and quantity

Wind the tape back on the reel so that the cover tape will be outside the tape.

Attach more than 20cm of blank tape to the trailer and the leader of the tape and fix the both ends with adhesive tape.

One reel shall contain 2000pcs, except for the item 2-5 above.

Continuous lack of components more than 2 shall not be acceptable.

5. Safety protection during shipping

There shall be no deformation of component or degradation of electrical characteristics due to shipping.

REFERENCE

Taping moisture-proof packing

1. Application

This packing specification sheets apply to the moist-proof packing for the GP2W3240YP in the taping package.

2. Packaging specifications

2.1 Packaging material

Name	Material	Q'ty
Aluminum laminate bag	Aluminum polyethylene	Refer to 2.2
Label	Paper (-made)	
Siccative	-	
Packing case	Paper	
Pads	Paper	
Indicator	Paper	

2.2 Packaging method

- (1) Seal the aluminum laminated bag that contains tape reel (contains 2,000 devices per reel) and siccative.
- (2) Fill necessary information to the label and paste it on the aluminum laminate bag.
- (3) Pack 4 aluminum laminated bags (contains 1 reel each) into the packing case, where paper pads are placed on the bottom and top of the packing case, as well as each layer of the aluminum laminated bags.

Package shape	Product	Q'ty	Moisture-proof sack Q'ty
Tape reel (330mm)	1 model	2000pcs./reel	1reel/laminated bag

Minimum order/shipment q'ty should be 1 laminated bag.

- (4) The packing case would be then sealed with the kraft tape, with indication of model name quantity, and outgoing inspection date on the case.
(total of 8,000pcs. per carton) * Except for the case that device is removed.

3. Storage and Treatment after Unsealed

3.1 Storage conditions The delivered product should be stored with the conditions shown below;

Storage temperature : 10 to 30

Humidity : below 70%RH

3.2 Treatment after open

- (1) After unsealed, devices should be mounted under the temperature condition of 10 to 30 , at the humidity condition of below 70%RH, within 2 days.
- (2) In case that long term storage is needed, devices should either be stored in dry box, or re-sealed to moist-proof bag with siccative and leave them in the environment where the temperature is 10 to 30 , at the humidity condition of below 70%RH. Devices must be mounted within 2 weeks.

3.3 Baking before mounting

In the event that the devices are not maintained in the storage conditions described above, or the enclosed siccative indicator already turned its color to pink, baking must be applied before devices are to be mounted.

The case that GP2W3240YP was not mounted under the temperature condition of 10 to 30 , at humidity condition of 70%RH or lower within 2 days after 1st time reflow , baking process must be applied before 2nd time reflow.:

Please also note that baking should only be applied once.

- Device with reel

Recommended condition : 65 , 48 hours

Only one reel shall be put in the oven for baking process. There is possibility of deformation of the reel when baking is done with the reels piled up in the oven.

- Device only

Recommended condition : 100 to 110 , 12 to 24 hours

Baking will not properly done in packing condition. To complete the baking properly, devices should either be temporary mounted to PCB with adhesive, or placed to the metal tray.

(The temporary mounting shall not be done by soldering, but by adhesive etc.)

REFERENCE

2-2. Tape structure and Dimensions

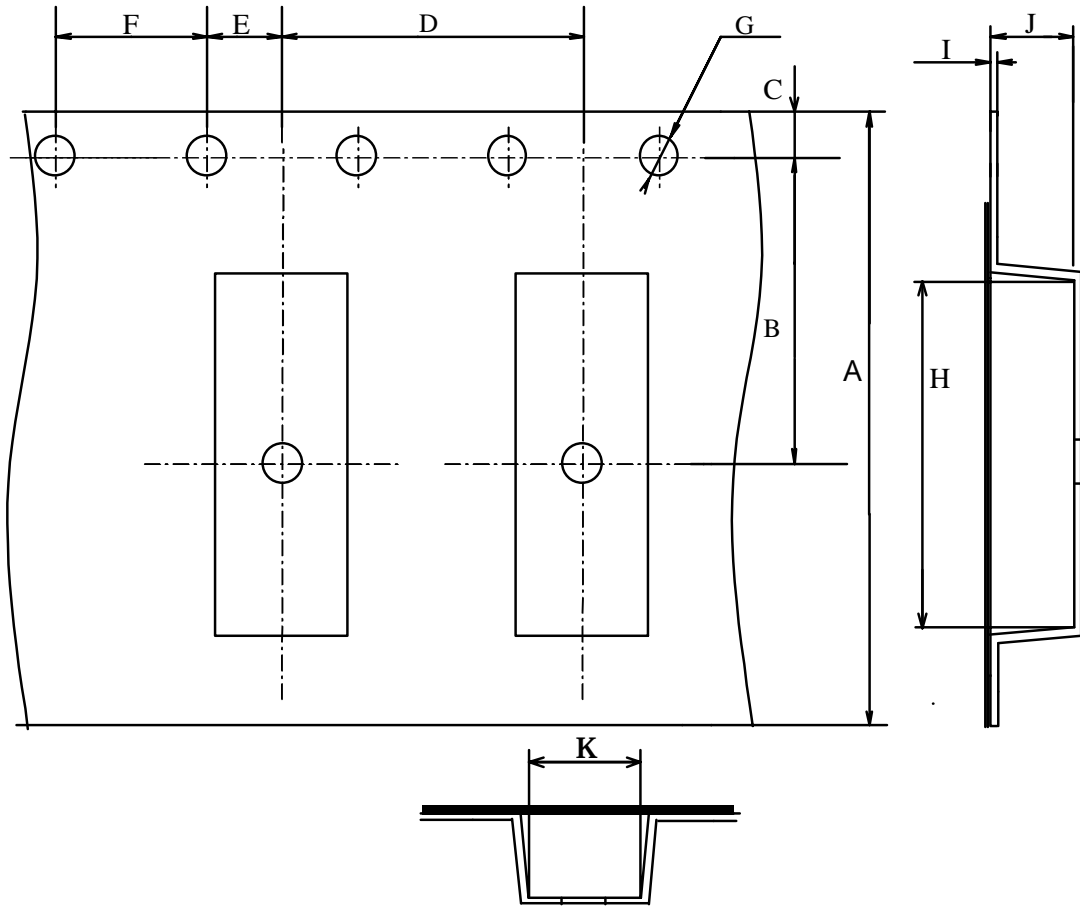

Symbol Unit	A	B	C	D	E	F
mm	± 0.3	± 0.1	± 0.1	± 0.1	± 0.1	± 0.1
	16.0	7.5	1.75	8.0	2.0	4.0

Symbol Unit	G	H	I	J	K
mm	$\begin{matrix} +0.1 \\ -0.0 \end{matrix}$	± 0.1	± 0.05	± 0.1	± 0.1
	1.5	9.00	0.32	2.05	2.40

REFERENCE

2-3. Reel structure and Dimensions

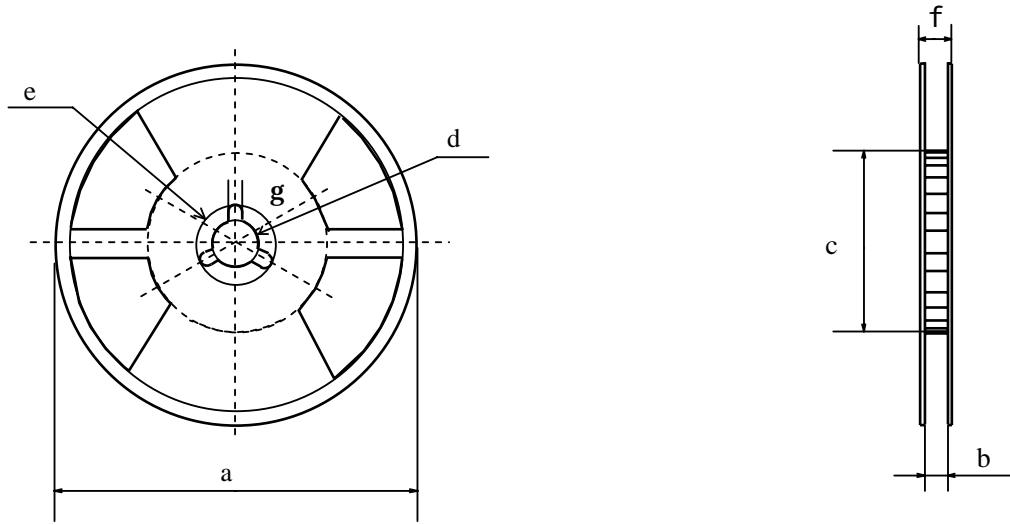

Symbol Unit	Check word						
	a	b	c	d	e	f	g
mm	330±2	17.5±0.5	100±1	13±0.2	21±0.8	22.4±1.0	2±0.5

2-3. Direction of product insertion

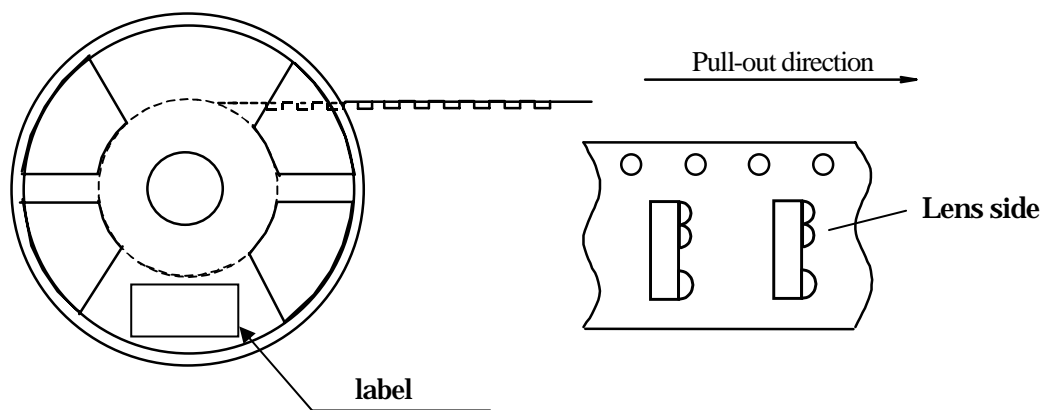

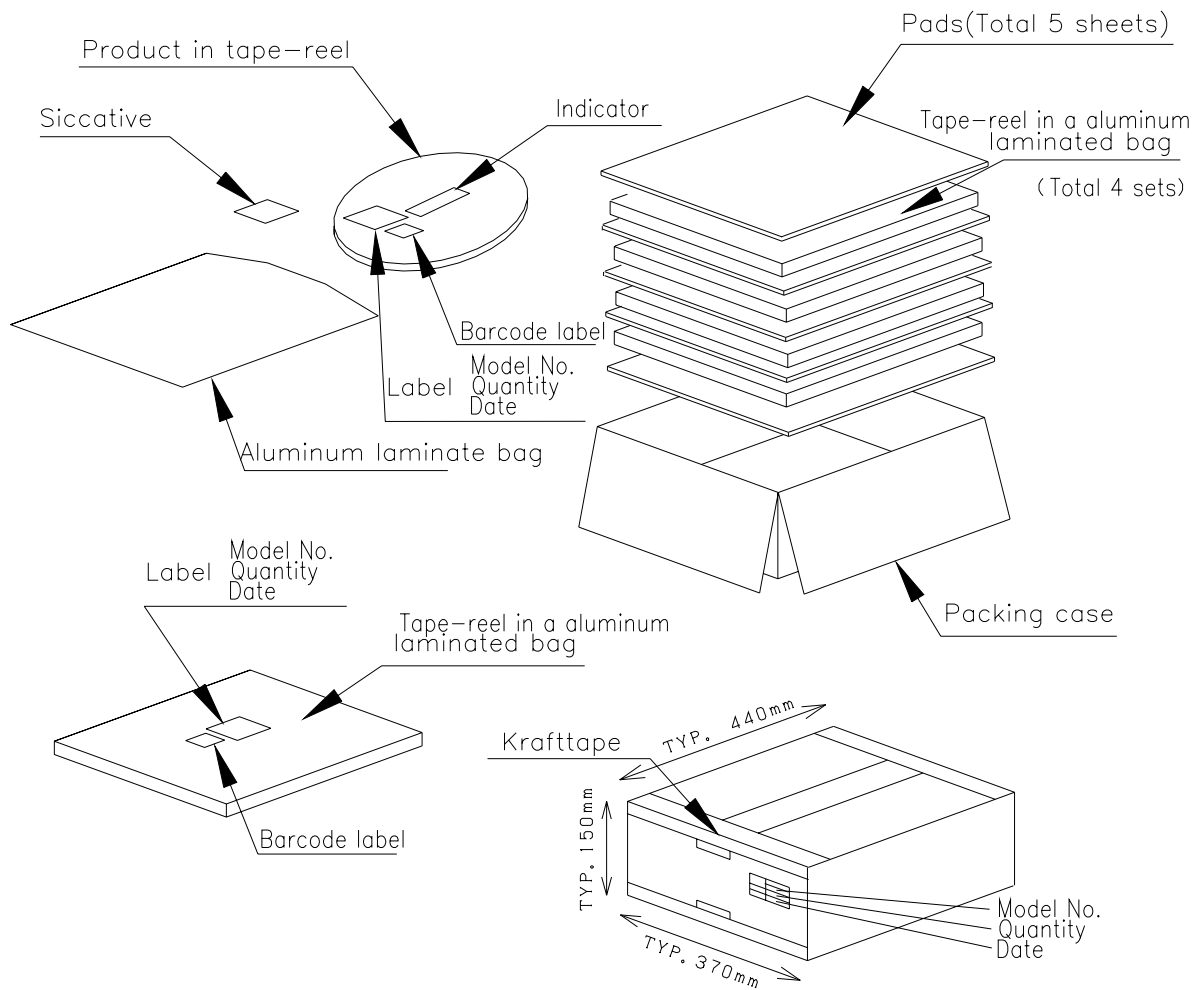

Package method

- (1) Seal the aluminum laminated bag included the tape reel with 2000pcs. and siccative.
- (2) Fill up the model name, quantity etc. in the blank of label and paste on the bag.
- (3) Put the four moisture-proof laminated bag in the ruled case.
Put the pad between the bags, and top and bottom.
- (4) The case seals with kraft tape, and indicate model No., quantity and date.
(8000pcs./package)

Total packaged mass : Approx 3.3kg

Name	GP2W3240YP Packing specification
------	-------------------------------------