

TPS 333 - Thermopile Detector

Miniature Sensor Housing

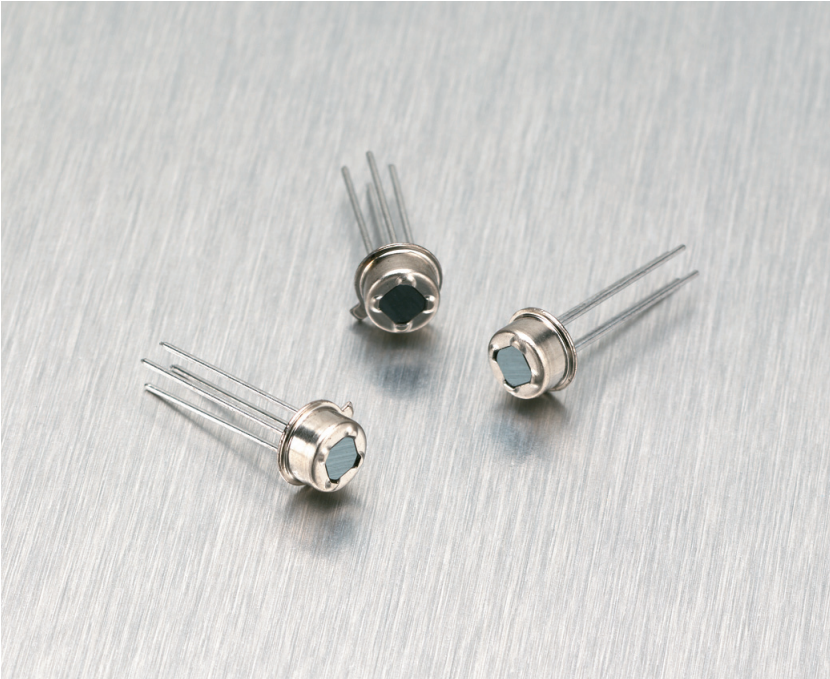

Description

The **TPS 333** is an extremely small thermopile detector employing a chip of $0.7 \times 0.7 \text{ mm}^2$ absorber size and a $100 \text{ k}\Omega$ thermistor as a temperature reference.

The square window opening is equipped with a $5.5 \text{ }\mu\text{m}$ longpass (standard) infrared filter. The detector shows a constant sensitivity characteristics over the wavelength.

Features

- Miniature Sensor Housing: TO 18
- Thermistor Temperature Reference Included
- Large Signal; Low Temperature coefficient of sensitivity
- Ideally Suited for Ear Thermometers, Miniature Pyrometers

TPS 333 - Thermopile Detector Miniature Sensor Housing

Figure 1. Package Drawing

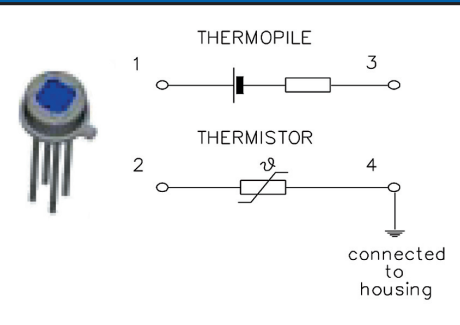

Figure 2.

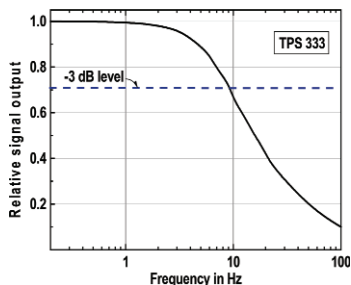

Figure 3.

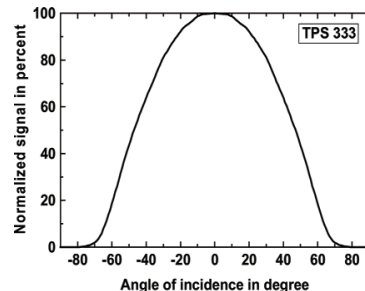

Figure 4. Top View Package Dimension

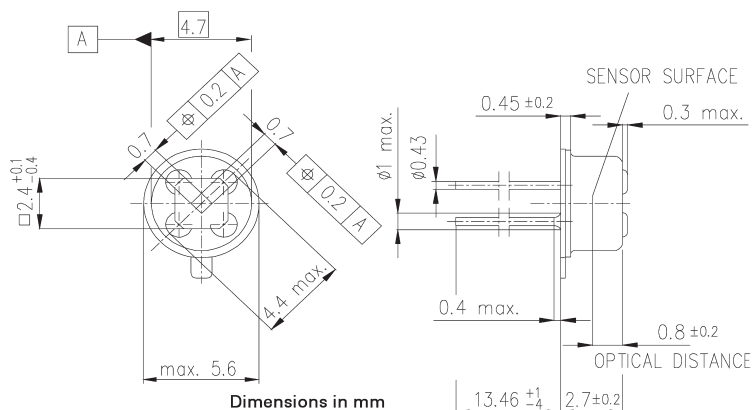

Figure 5. Bottom View

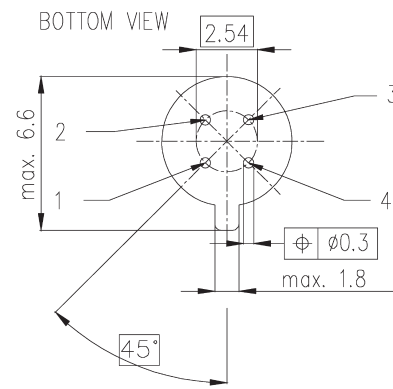

Table 1. TPS 333

Parameter	Typical	Units	Condition
Sensitive area	0.7 x 0.7	mm ²	absorbing area
Window size	2.4 x 2.4	mm ²	
DC sensitivity	35	V/W	500K BB 5 ... 14µm
Resistance	75	kΩ	
Noise	38	nV/√Hz	r.m.s. 300K
NEP	1.2	nW/√Hz	500K BB 5 ... 14µm
D*	0.6 x 10 ⁸	cm√Hz/W	500K BB 5 ... 14µm
TC of sensitivity	0.02	%/K	
TC of resistance	0.02	%/K	
Time constant	25	ms	
Operating temperature	-40 to 100	°C	non permanent
Storage temperature	-40 to 100	°C	non permanent
Thermistor resistance	100	kΩ	25°C
beta	3964	K	25°C/100°C
Field of view	100	°	at 50% points

For more information e-mail us at opto@perkinelmer.com or visit our website at www.perkinelmer.com/optoelectronics

All values are nominal; specifications subject to change without notice.

North America:
PerkinElmer Optoelectronics
16800 Trans-Canada Highway
Kirkland, Quebec J7V 8P7 Canada
Toll Free: (877) 734-OPTO (6786)
Phone: +1-450-424-3300
Fax: +1-450-424-3411

Europe:
PerkinElmer Optoelectronics
Wenzel-Jaksch-Str. 31
D-65199 Wiesbaden, Germany
Phone: +49-611-492-430
Fax: +49-611-492-165

Asia:
PerkinElmer Optoelectronics
47 Ayer Rajah Crescent #06-12
Singapore 139947
Phone: +65-6770-4366
Fax: +65-6775-1008

