

TPS 534 - Thermopile Detector

Large Absorber Size

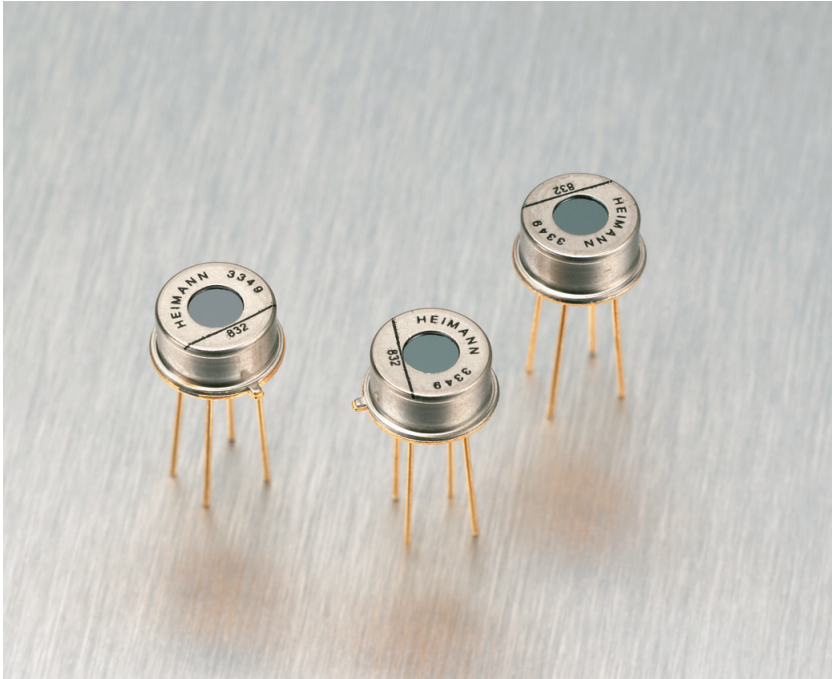

Description

The **TPS 534** thermopile sensor in a TO 5 type housing employs a chip of $1.2 \times 1.2 \text{ mm}^2$ absorber size and a $30 \text{ k}\Omega$ thermistor as temperature reference. The round window opening is equipped with a $5.5 \mu\text{m}$ longpass (standard) infrared filter. The sensor shows a flat sensitivity characteristic over the wavelength.

Remark: The TPS 534 can also be equipped with infrared bandpass filters for NDIR gas detection.

Features

- Large Absorber Size - High Signal Output
- Low Temperature Coefficient of Sensitivity
- Thermistor Temperature Reference included
- Applications in Pyrometers, and with Additional Bandpass Filters, in Gas Detectors

TPS 534 - Thermopile Detector Large Absorber Size

Figure 1. Package Drawing

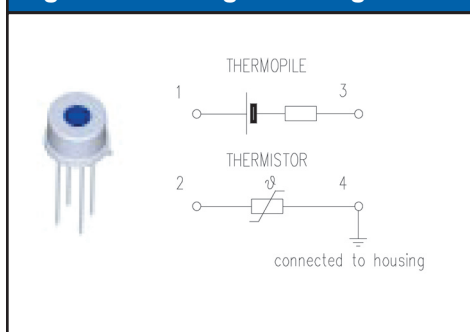

Figure 2.

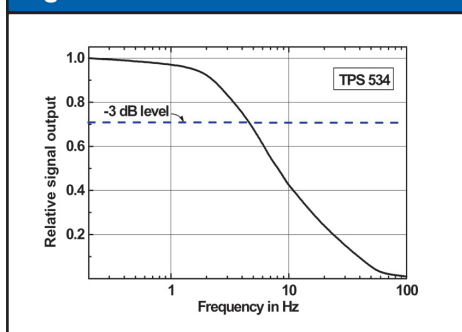

Figure 3.

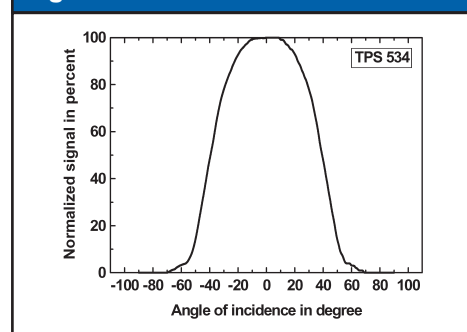

Figure 4. Top View Package Dimension

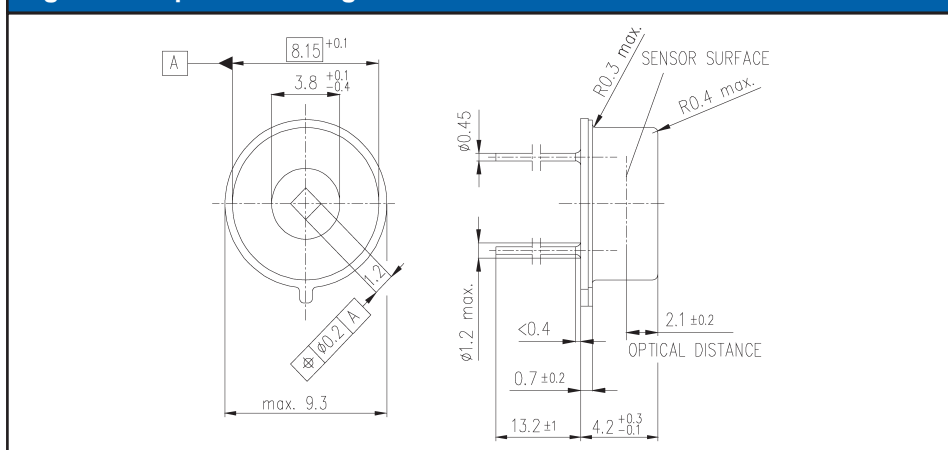

Figure 5. Bottom View

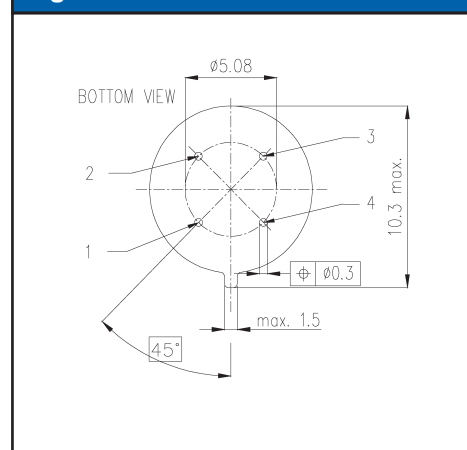

Table 1. TPS 534

Parameter	Typical	Units	Condition
Sensitive area	1.2 x 1.2	mm ²	absorbing area
Window size	3.8	mm	diameter
DC sensitivity	20	V/W	500K BB 5 ... 14μm
Resistance	40	kΩ	25°C
Noise	25	nV/√Hz	r.m.s. 300K, 1 Hz
NEP	1.26	nW/√Hz	500K BB 5 ... 14μm
D*	0.96 x 10 ⁸	cm√Hz/W	500K BB 5 ... 14μm
TC of responsivity	-0.01	%/K	
TC of resistance	0.02	%/K	
Time constant	35	ms	
Operating temperature	-40 to 100	°C	non permanent
Storage temperature	-40 to 100	°C	non permanent
Thermistor resistance	30	kΩ	25°C
beta	3964	K	25°C/100°C
Field of view	80	°	at 50% points

For more information e-mail us at opto@perkinelmer.com or visit our website at www.perkinelmer.com/optoelectronics

All values are nominal; specifications subject to change without notice.

North America:
PerkinElmer Optoelectronics
16800 Trans-Canada Highway
Kirkland, Quebec J7V 8P7 Canada
Toll Free: (877) 734-OPTO (6786)
Phone: +1-450-424-3300
Fax: +1-450-424-3411

Europe:
PerkinElmer Optoelectronics
Wenzel-Jaksch-Str. 31
D-65199 Wiesbaden, Germany
Phone: +49-611-492-430
Fax: +49-611-492-165

Asia:
PerkinElmer Optoelectronics
47 Ayer Rajah Crescent #06-12
Singapore 139947
Phone: +65-6770-4366
Fax: +65-6775-1008

