

Agilent ADNS-2051 Optical Mouse Sensor Product Brief

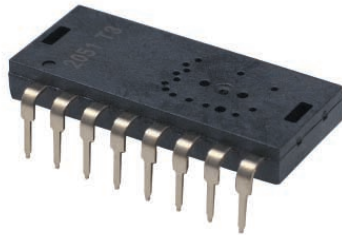
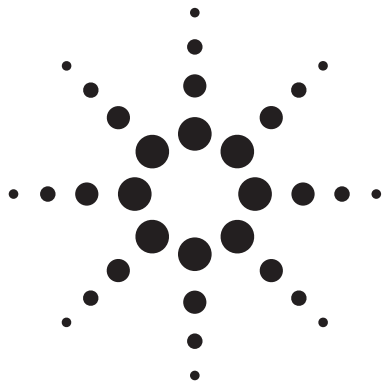

Description

High Performance Optical Mouse Sensor for More Precise Navigation

The ADNS-2051 is a low cost reflective optical sensor that provides a non-mechanical tracking engine for implementing a computer pointing device. It is based on optical navigation technology which measures changes in position by optically acquiring sequential surface images up to 2300 times per second and mathematically determining the direction and magnitude of movement at the maximum of 800 counts per inch (cpi) and at speeds up to 14 inches per second (ips). Agilent provides the complete optical mouse reference design kit (Part # ADNK-2051). The CMOS based sensor is mounted in a 16 pin staggered dual in-line package (DIP) and designed for use with the

HDNS-2200 (LED Assembly Clip) and HLMP-ED80 (639 nm LED illumination source) and HDNS-2100 (lens).

Theory of Operation

The ADNS-2051 is based on Optical Navigation Technology. It contains an Image Acquisition System (IAS), a Digital Signal Processor (DSP), a two-channel quadrature output, and a two-wire serial port.

The IAS acquires microscopic surface images via the lens and illumination system provided by the HDNS-2100, 2200, and HLMP-ED80. These images are processed by the DSP to determine the direction and distance of motion. The DSP generates the Δx and Δy relative displacement values that are converted into two channel quadrature signals.

Features

- Precise optical navigation technology
- No mechanical moving parts
- Complete 2D motion sensor
- Serial interface and/or quadrature interface
- Smooth surface navigation
- Programmable frame speed up to 2300 frames per sec (fps)
- Accurate motion up to 14 ips
- 800 cpi resolution
- High reliability
- High speed motion detector
- No precision optical alignment
- Wave solderable
- Single 5.0 volt power supply
- Shutdown pin for USB suspend mode operation
- Power conservation mode during times of no movement
- On chip LED drive with regulated current
- Serial port registers
 - Programming
 - Data transfer
- 16-pin staggered dual in-line package (DIP)

Applications

- Mice for desktop PCs, workstations, and portable PCs
- Trackballs
- Integrated input devices

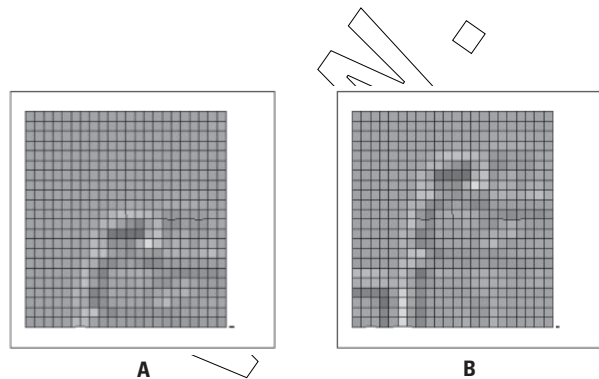

Figure 1. The Navigation Engine identifies common features in sequential images to determine the direction and amount of mouse movement. Image B was taken while the mouse was moving, a short time after image A.

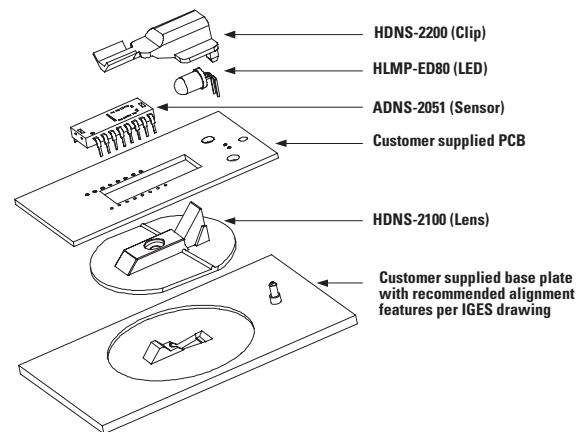

Figure 2. Exploded view drawing of optical mouse components.



Agilent Technologies

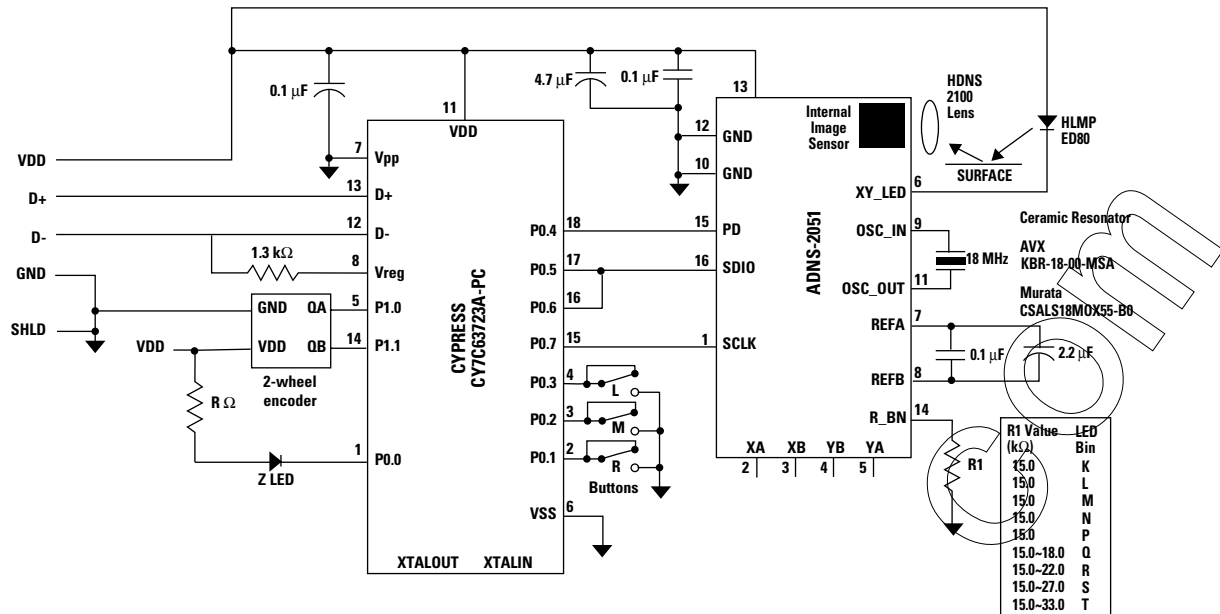

Figure 3. Circuit-level block diagram for optical mouse solution using ADNS-2051 optical mouse sensor.

ADNS-2051 Specifications

Parameter	Symbol	Min.	Typ.	Max.	Units	Notes
Operating Temperature	T_A	0		40	$^{\circ}\text{C}$	
Power Supply Voltage	V_{DD}	4.25	5.0	5.5	V	Register values retained for voltage transients below 4.25V but greater than 4V
DC Supply Current (mouse moving)	$I_{DD\text{AVG}}$		15	25	mA	No load on XA, XB, YA, YB, SCLK, SDIO. Excluding LED current
Peak Supply Current (mouse moving)	$I_{DD\text{PEAK}}$		20		mA	No load on XA, XB, YA, YB, SCLK, SDIO. Excluding LED current
DC Supply Current (mouse not moving)	I_{DD}		12	25	mA	No load on XA, XB, YA, YB, SCLK, SDIO. Excluding LED current
DC Supply Current (power down)	I_{DDPD}		170	240	μA	PD = high; SCLK, SDIO = GND or V_{DD} ; $V_{DD} = 4.25\text{V to } 5.25\text{V}$
Clock Frequency	f_{CLK}	17.4	18.0	18.7	MHz	Set by ceramic resonator
Resonator Impedance	X_{RES}			55	Ω	
Distance from lens reference plane to surface	Z	2.3	2.4	2.5	mm	Results in ± 0.2 mm DOF
Speed	S	0		14	in/sec	@ frame rate = 1500 frames/second
Acceleration	A			0.15	g	@ frame rate = 1500 frames/second
Light level onto IC	IRR_{INC}	80		25,000	mW/m^2	$\lambda = 639$ nm $\lambda = 875$ nm
Resolution	RES		400	800	counts/in	
Frame Rate	FR		1500	2300	frames/s	

For product information and a complete list of Agilent contacts and distributors, please go to our web site.

www.agilent.com/semiconductors

E-mail: SemiconductorSupport@agilent.com

Data subject to change.

Copyright © 2002 Agilent Technologies, Inc.

Obsoletes 5988-4290EN

January 8, 2002

5988-5084EN



Agilent Technologies