

TPS 2534 - Dual Channel Thermopile

Two Thermopiles with Individual Infrared Filters



Description

The dual thermopile sensor **TPS 2534** employs two single thermopile chips mounted in a TO-5 housing with a 40 k Ω thermistor as temperature reference. The cap has two windows of size 2.3 x 2.6 mm² each which can be equipped with different infrared bandpass filters. The sensor is perfectly suited to gas detection by IR absorption.

For further information please refer to the TPS 2534 product note.

Features

- Thermistor Temperature Reference Included
- Applications: Infrared Absorption (NDIR) Gas Sensing with Reference Channel

TPS 2534 - Dual Channel Thermopile Two Thermopiles with Individual Infrared Filters

Figure 1. Package Drawing

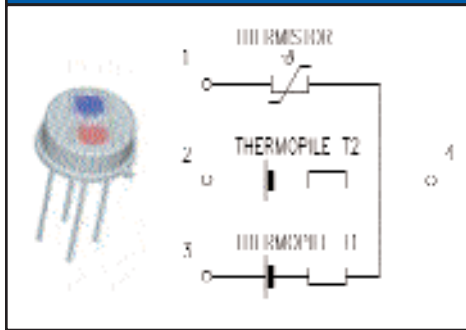

Figure 2.

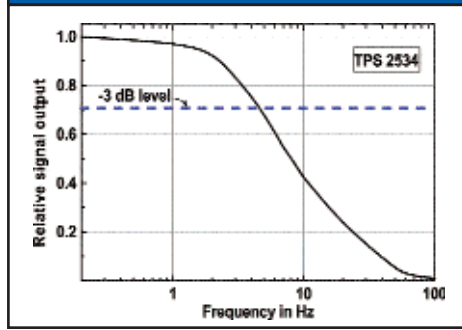

Figure 3.

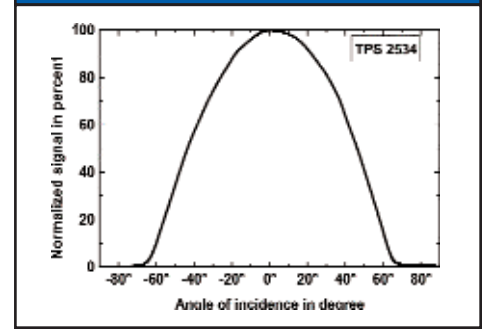

Figure 4. Top View Package Dimension

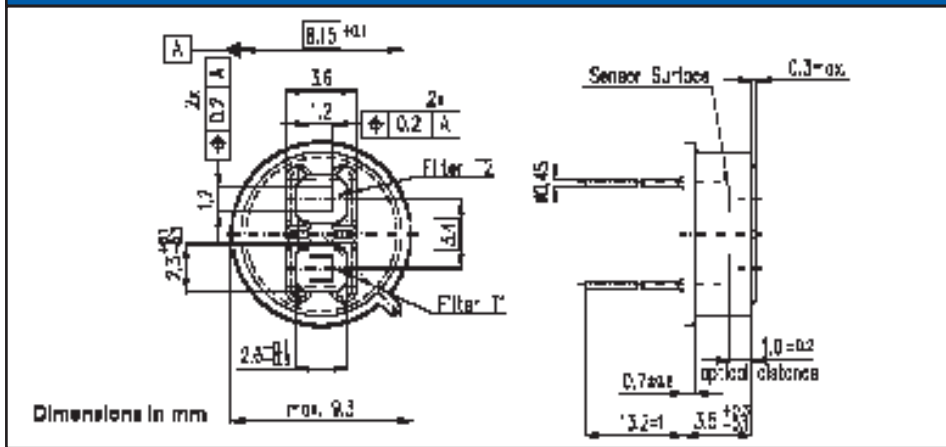

Figure 5. Bottom View

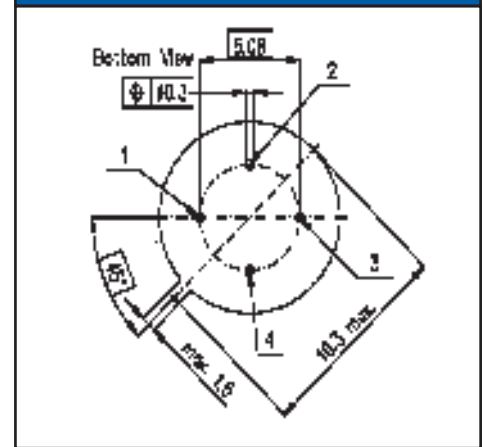

Table 1. TPS 2534

Parameter	Typical	Units	Condition
Sensitive area	2x 1.2 x 1.2	mm ²	absorbing area
Window size	2.3 x 2.6	mm ²	each channel
DC sensitivity	42	V/W	500K BB w/o filter
Resistance	30	kΩ	
Noise	30	nV/√Hz	r.m.s. 300K
NEP	10.7	nW/√Hz	500K BB w/o filter
D*	2.3 x 10 ⁸	cm√Hz/W	500K BB w/o filter
TC of sensitivity	-0.01	%/K	
TC of resistance	0.02	%/K	
Time constant	35	ms	
Operating temperature	-40 to 100	°C	non permanent
Storage temperature	-40 to 100	°C	non permanent
Thermistor resistance	30	kΩ	25°C
beta	3964	K	25°C/100°C
Field of view	2x 90	°	at 50% points

For more information e-mail us at opto@perkinelmer.com or visit our website at www.perkinelmer.com/optoelectronics
 All values are nominal; specifications subject to change without notice.

North America:
 PerkinElmer Optoelectronics
 16800 Trans-Canada Highway
 Kirkland, Quebec J7V 8P7 Canada
 Toll Free: (877) 734-OPTO (6786)
 Phone: +1-450-424-3300
 Fax: +1-450-424-3411

Europe:
 PerkinElmer Optoelectronics
 Wenzel-Jaksch-Str. 31
 D-65199 Wiesbaden, Germany
 Phone: +49-611-492-430
 Fax: +49-611-492-165

Asia:
 PerkinElmer Optoelectronics
 47 Ayer Rajah Crescent #06-12
 Singapore 139947
 Phone: +65-6770-4366
 Fax: +65-6775-1008

