

Request For Quotation

Order the parts you need from our real-time inventory database. Simply complete a request for quotation form with your part information and a sales representative will respond to you with price and availability.

[Request For Quotation](#)

Your free datasheet starts on the next page.

More datasheets and data books are available from our homepage: <http://www.datasheetarchive.com>

www.datasheetarchive.com

Plastic Fiber Optic Transmitter Diode Plastic Connector Housing

SFH 752
SFH 752V

Not for new design

Features

- 2.2 mm aperture holds standard 1000 micron plastic fiber
- No fiber stripping required
- Good linearity
- Molded microlens for efficient coupling

Plastic Connector Housing

- Mounting screw attached to the connector
- Interference-free transmission from light-tight housing
- Transmitter and receiver can be flexibly positioned
- No cross talk
- Auto insertable and wave solderable
- Supplied in tubes

Applications

- Household electronics
- Power electronics
- Optical networks
- Medical instruments
- Automotive electronics
- Light barriers

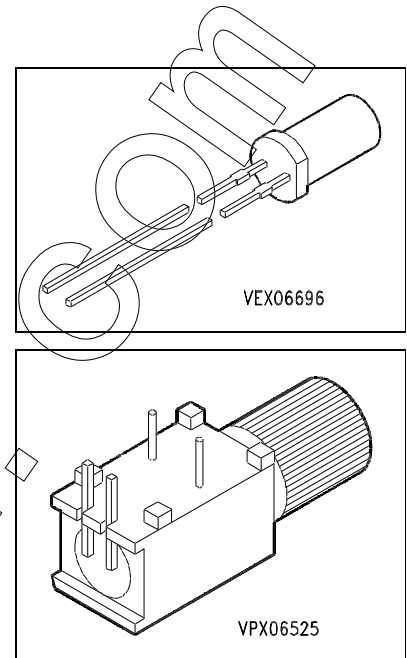

Type	Ordering Code
SFH 752	Q62702-P210
SFH 752V	Q62702-P284

Maximum Ratings

Parameter	Symbol	Values	Unit
Operating temperature range	T_{OP}	- 55 ... + 100	°C
Storage temperature range	T_{STG}	- 55 ... + 100	°C
Junction temperature	T_J	100	°C
Soldering temperature (2 mm from case bottom, $t \leq 5$ s)	T_S	260	°C
Reverse voltage	V_R	3	V

Maximum Ratings (cont'd)

Parameter	Symbol	Values	Unit
Forward current	I_F	45	mA
Surge current $t \leq 10 \mu\text{s}$, $D = 0$	I_{FSM}	1	A
Power dissipation	P_{tot}	150	mW
Thermal resistance, junction/air	R_{thJA}	500	K/W

Characteristics ($T_A = 25 \text{ }^\circ\text{C}$)

Parameter	Symbol	Values	Unit
Peak wavelength	λ_{Peak}	665	nm
Spectral bandwidth	$\Delta\lambda$	25	nm
Switching times ($R_L = 50 \Omega$, $I_F = 10 \text{ mA}$) 10 % ... 90 % 90 % ... 10 %	t_R t_F	0.07 0.1	μs μs
Capacitance ($f = 1 \text{ MHz}$, $V_R = 0 \text{ V}$)	C_O	30	pF
Forward voltage ($I_F = 10 \text{ mA}$)	V_F	2 (≤ 2.6)	V
Output power coupled into plastic fiber ($I_F = 10 \text{ mA}$) see Note 1	Φ_{IN}	25 ... 125	μW
Temperature coefficient Φ_{IN}	TC_Φ	-0.5	%/K
Temperature coefficient V_F	TC_V	-2.0	mV/K
Temperature coefficient λ_{Peak}	TC_λ	0.16	nm/K

Note 1: The output power coupled into plastic fiber is measured with a large area detector at the end of a short length of fiber (about 30 cm). This value must not be used for calculating the power budget for a fiber optic system with a long fiber because the numerical aperture of plastic fibers decreases on the first meters. Therefore the fiber seems to have a higher attenuation over the first few meters compared with the specified value.

Relative spectral emission $I_{rel} = f(\lambda)$

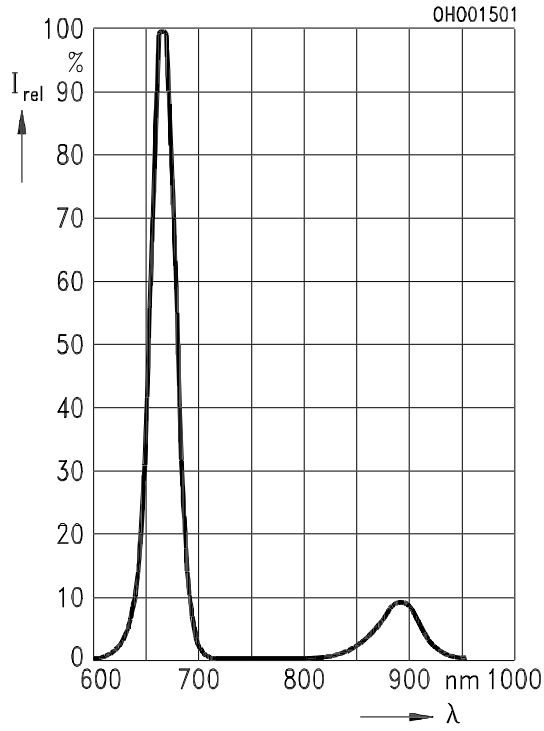

Forward current $I_F = f(V_F)$,
single pulse, duration = 20 μ s

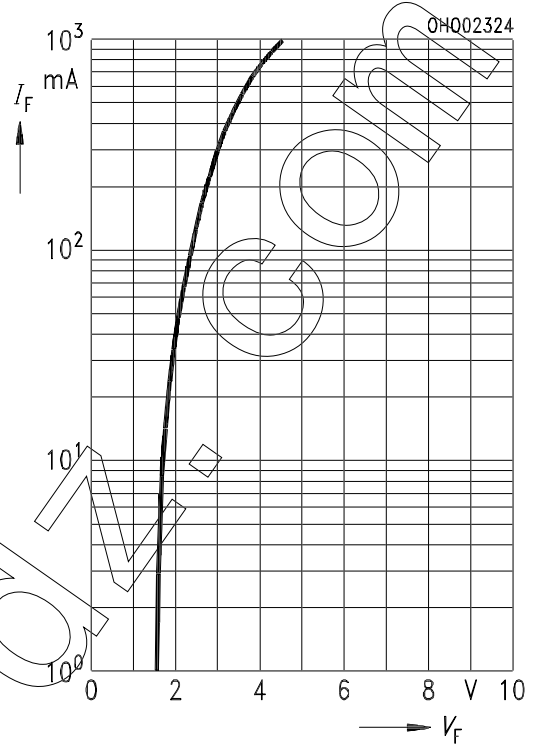

Relative optical output power

$\Phi_{IN}/\Phi_{IN}(10 \text{ mA}) = f(I_F)$

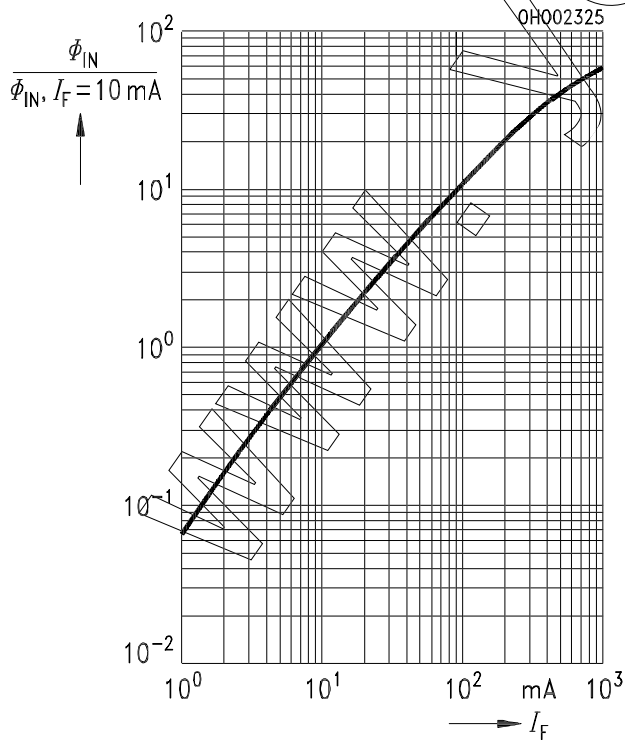

Maximum permissible forward current
 $I_F = f(T_A)$

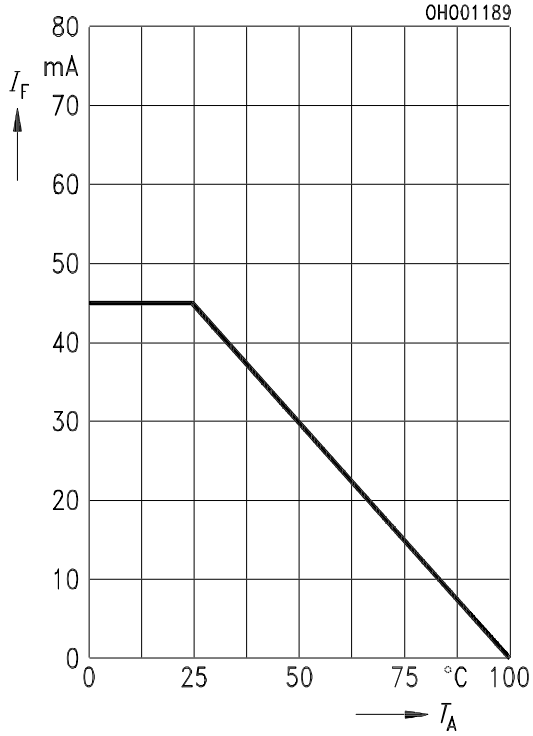

Permissible pulse load $I_F = f(t)$,
duty cycle $D = \text{parameter}$, $T_A = 25^\circ\text{C}$

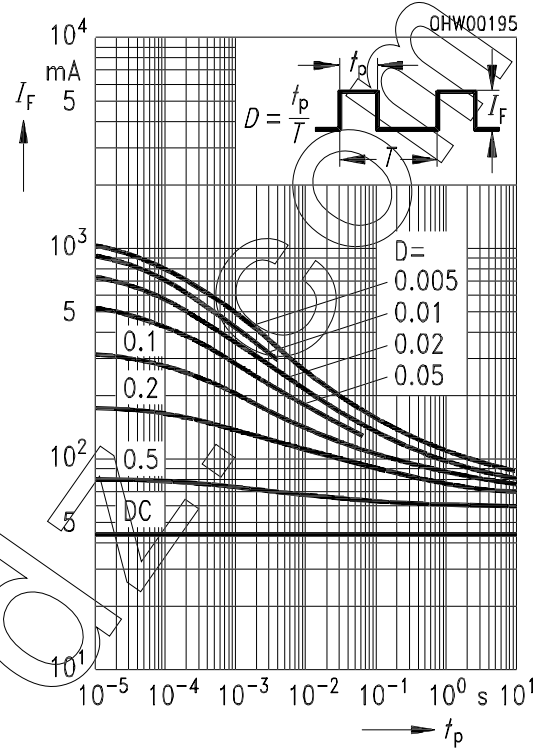

www.yc

Package Outlines (dimensions in mm, unless otherwise specified)

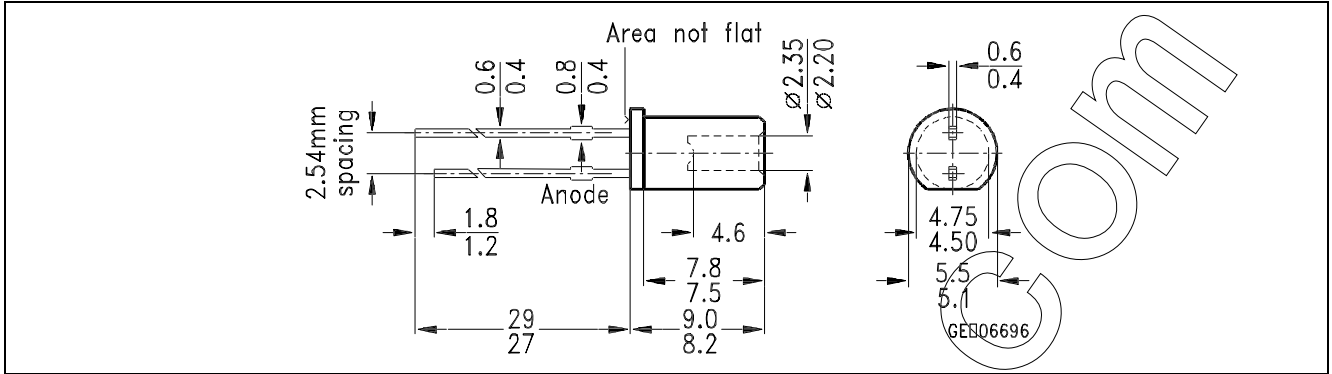

SFH 752

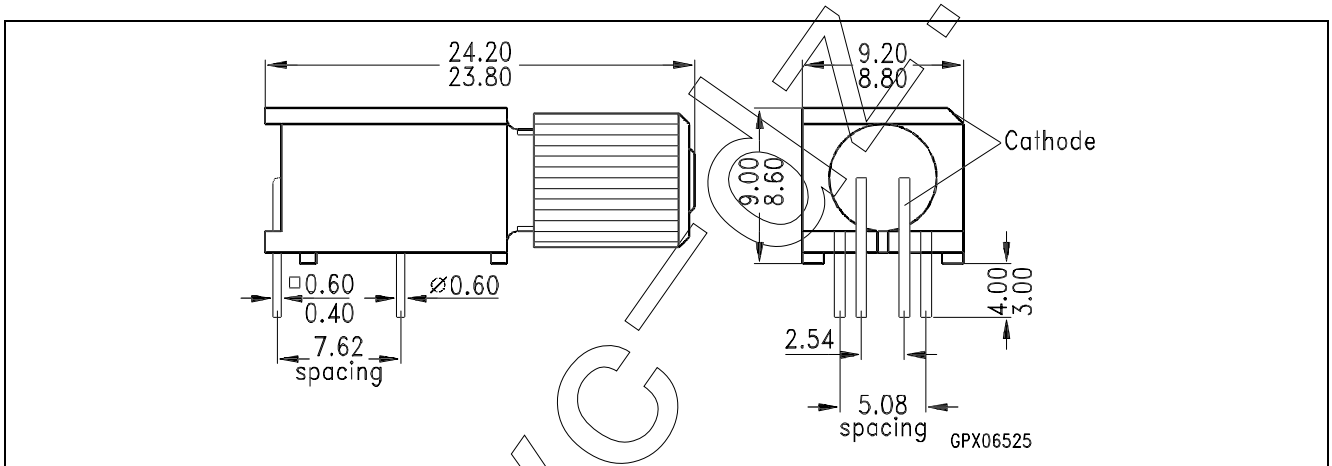

SFH 752V