

Schmitt-Trigger IC im TO-18 Gehäuse mit Glaslinse
Schmitt-Trigger IC in TO-18 Package with Glass Lens
Lead (Pb) Free Product - RoHS Compliant

SFH 5840
SFH 5841



Wesentliche Merkmale

- SFH 5840: Ausgang active low
- SFH 5841: Ausgang active high
- Hermetisch dichte Metallbauform
- Geeignet für Anwendungen im Bereich von 400 nm bis 1100 nm

Features

- SFH 5840: Output active low
- SFH 5841: Output active high
- Hermetically sealed metal package (TO-18)
- Suitable for applications from 400 nm to 1100 nm

Anwendungen

- Optischer Schalter
- Pulsformer
- Zähler

Applications

- Optical threshold switch
- Pulseformer
- Counter

Typ Type	Bestellnummer Ordering Code	Gehäuse Package
SFH 5840	Q62702P5116	Metallbauform (TO-18), OUT-Kennzeichnung: „Nase“ am Gehäuse
SFH 5841	Q62702P5117	Metal package (TO-18), OUT-marking: projection at package

Grenzwerte ($T_A = 25\text{ °C}$)**Maximum Ratings**

Bezeichnung Parameter	Symbol Symbol	Wert Value	Einheit Unit
Betriebs- und Lagertemperatur Operating and storage temperature range	$T_{op}; T_{stg}$	- 40 ... + 85	°C
Versorgungsspannung Supply voltage	V_{CC}	- 0.5 ... + 20	V
Ausgangsspannung Output voltage	V_O	- 0.5 ... + 20	V
Ausgangsstrom Output current	I_O	50	mA
Verlustleistung Power dissipation	P_{tot}	175	mW

Empfohlener Arbeitsbereich**Recommended Operating Conditions**

Bezeichnung Parameter	Symbol Symbol	Wert Value	Einheit Unit
Versorgungsspannung Supply voltage	V_{CC}	4 ... 18	V
Ausgangsstrom Output current	I_O	< 16	mA

Zur Stabilisierung der Versorgung wird ein Stützkondensator (angeschlossen zwischen V_{CC} und GND) von typ. 0.1 μF empfohlen.

A bypass capacitor, 0.1 μF typical, connected between V_{CC} and GND is recommended in order to stabilize power supply line.

Kennwerte ($T_A = 25\text{ °C}$, $V_{CC} = 5\text{ V}$)**Characteristics**

Bezeichnung Parameter	Symbol Symbol	Wert Value	Einheit Unit
Ausgangsspannung „high“ Output voltage “high” $I_O = 0$	V_{OH}	$V_{CC} (> 4.0)$	V
Ausgangsspannung „low“ Output voltage “low” $I_O = 16\text{ mA}$	V_{OL}	0.15 (< 0.4)	V

Kennwerte ($T_A = 25\text{ °C}$, $V_{CC} = 5\text{ V}$)

Characteristics (cont'd)

Bezeichnung Parameter	Symbol Symbol	Wert Value	Einheit Unit
Stromaufnahme, $E = 0$ Supply current $V_{CC} = 5\text{ V}$ $V_{CC} = 18\text{ V}$	I_{CC}	3.3 (< 5) 5.0	mA
Schaltsschwelle, $\lambda = 950\text{ nm}$ Threshold SFH 5840: "H" → "L" SFH 5841: "L" → "H"	$E_{e, ON}$	10 (< 32)	$\mu\text{W}/\text{cm}^2$
Hysterese Hysteresis	$E_{e, OFF} / E_{e, ON}$	0.6 (0.5 ... 0.9)	–
Halbwinkel Half angle	φ	± 5	Grad degr.
Anstiegszeit 10% bis 90% Rise time 10% to 90% $R_L = 280\ \Omega$, $E_e = 60\ \mu\text{W}/\text{cm}^2$, $\lambda = 950\text{ nm}$	t_r	100	ns
Abfallzeit 90% bis 10% Fall time 90% to 10% $R_L = 280\ \Omega$, $E_e = 60\ \mu\text{W}/\text{cm}^2$, $\lambda = 950\text{ nm}$	t_f	100	ns
Ausgangsverzögerungszeit Propagation delay time "H" → "L" $R_L = 280\ \Omega$, $E_e = 60\ \mu\text{W}/\text{cm}^2$, $\lambda = 950\text{ nm}$	t_{PHL}	5 (< 15)	μs
Ausgangsverzögerungszeit Propagation delay time "L" → "H" $R_L = 280\ \Omega$, $E_e = 60\ \mu\text{W}/\text{cm}^2$, $\lambda = 950\text{ nm}$	t_{PLH}	5 (< 15)	μs

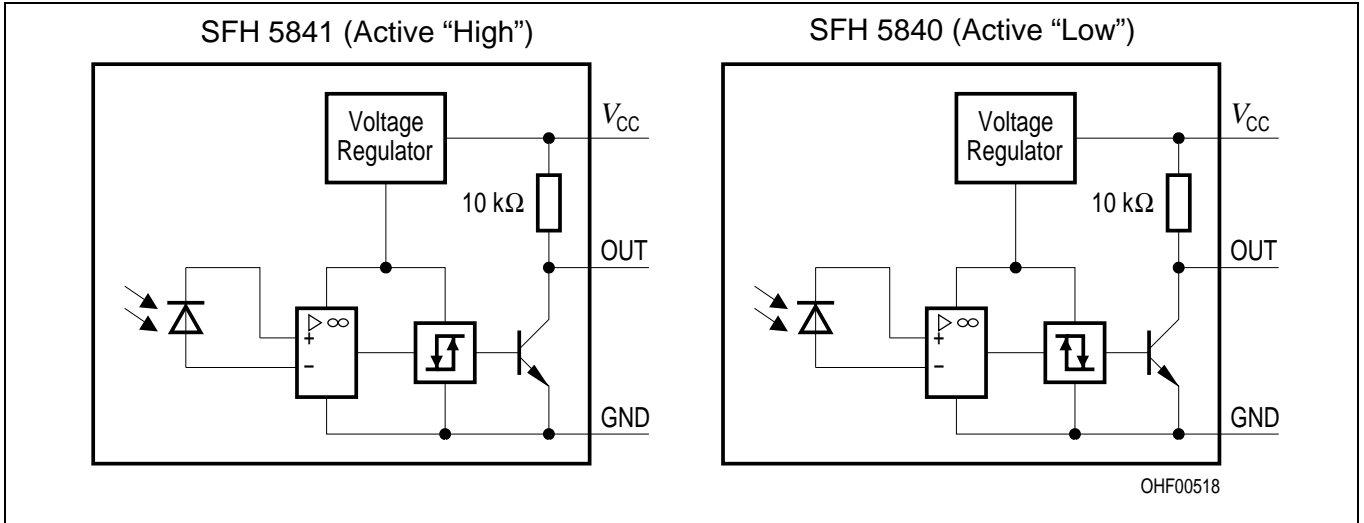

Figure 1 Block Diagram

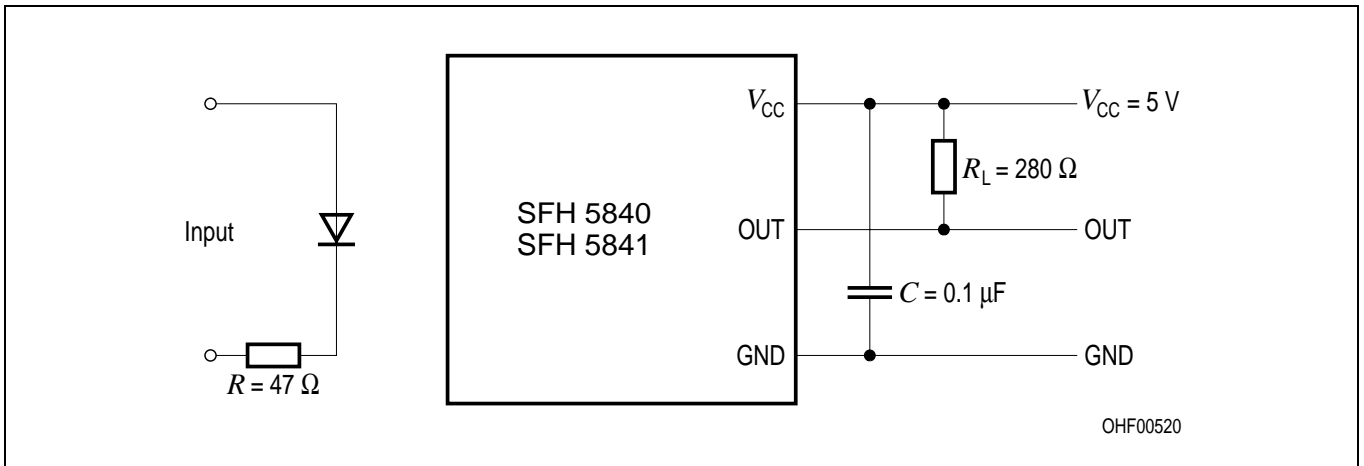

Figure 2 Test Circuit for Switching and Response Time

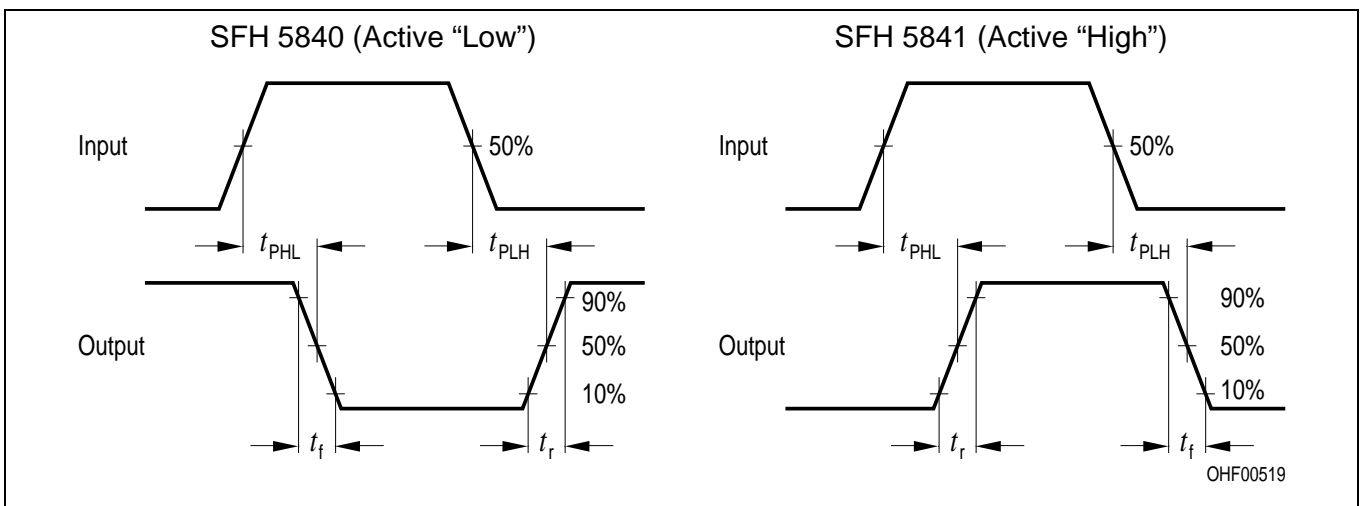
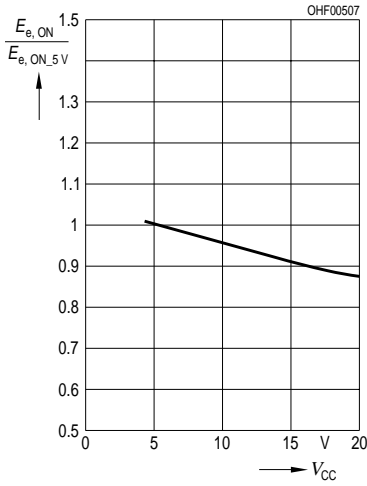

Figure 3 Switching Time Definitions

Relative Threshold

$$E_{e, ON} / E_{e, ON} (V_{CC} = 5 V) = f(V_{CC})$$



Supply Current

$$I_{CC} = f(V_{CC})$$

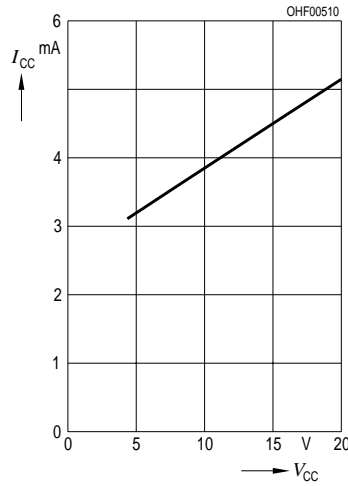

Total Power Dissipation

$$P_{tot} = f(T_A)$$

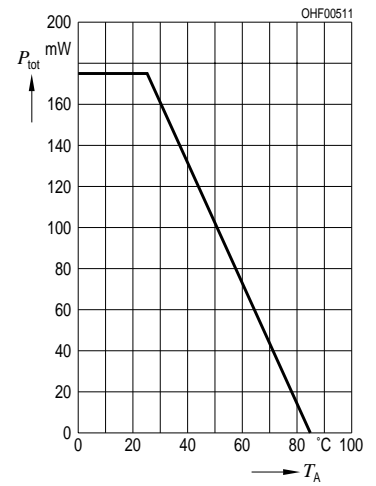

Output Voltage

$$V_{OL} = f(I_{OUT}, V_{CC})$$

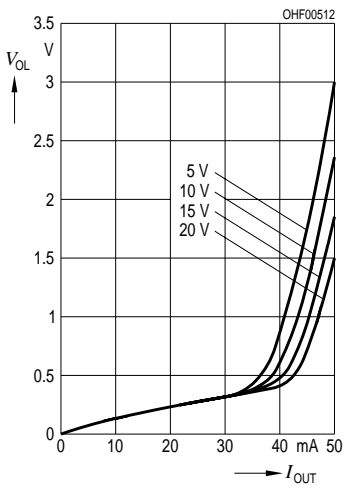

Supply Current vs. Ambient Temperature

$$I_{CC} = f(T_A, V_{CC})$$

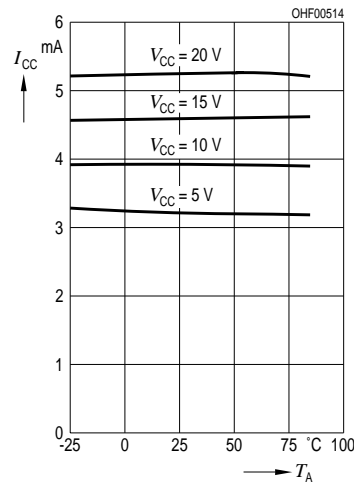

**Maßzeichnung
Package Outlines**

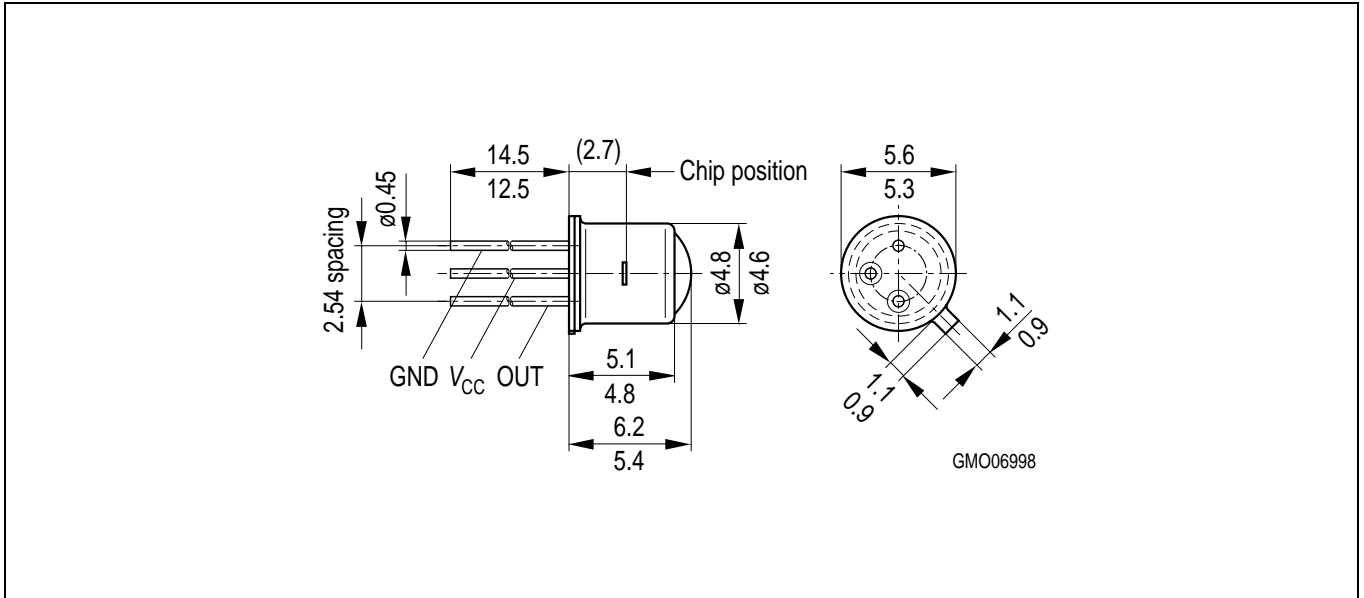

Maße in mm, wenn nicht anders angegeben / Dimensions in mm, unless otherwise specified.

**Lötbedingungen
Soldering Conditions
Wellenlöten (TTW)
TTW Soldering**

(nach CECC 00802)
(acc. to CECC 00802)

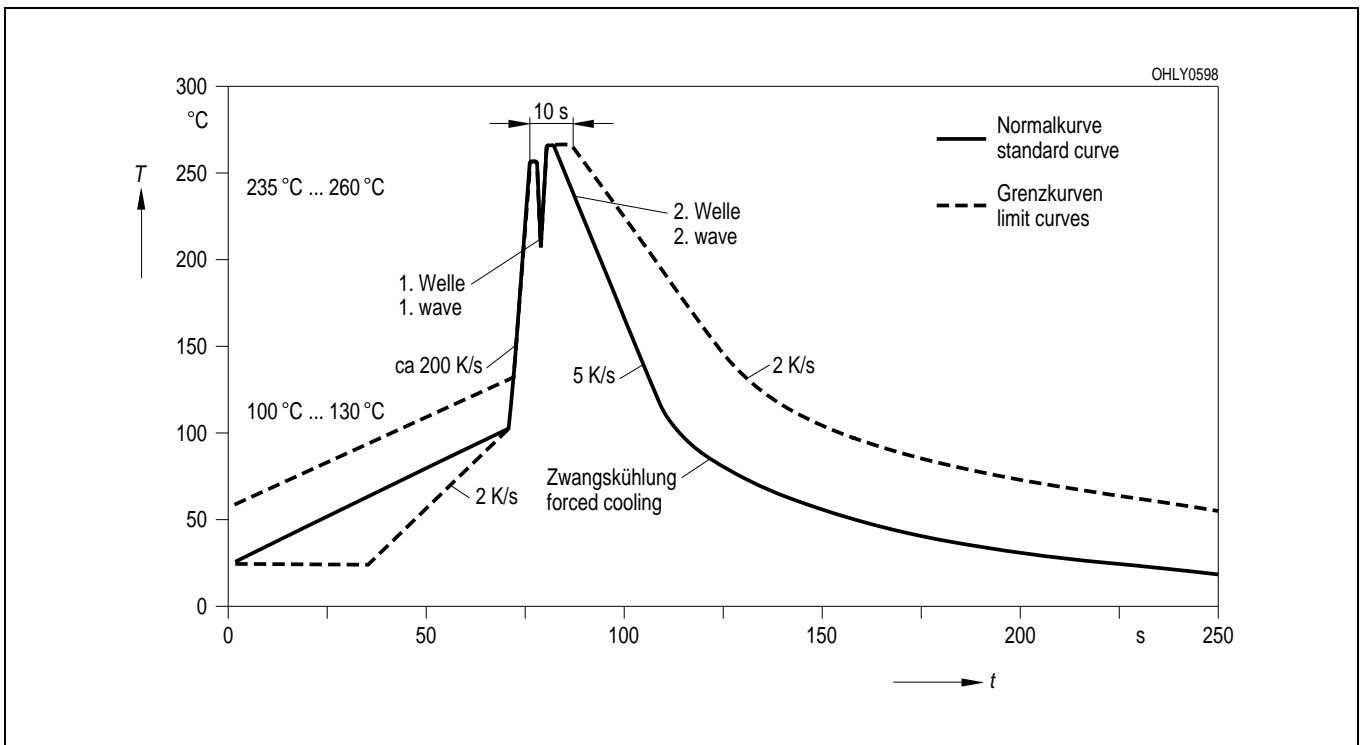

Published by
OSRAM Opto Semiconductors GmbH
Wernerwerkstrasse 2, D-93049 Regensburg
www.osram-os.com

© All Rights Reserved.

The information describes the type of component and shall not be considered as assured characteristics. Terms of delivery and rights to change design reserved. Due to technical requirements components may contain dangerous substances. For information on the types in question please contact our Sales Organization.

Packing

Please use the recycling operators known to you. We can also help you – get in touch with your nearest sales office. By agreement we will take packing material back, if it is sorted. You must bear the costs of transport. For packing material that is returned to us unsorted or which we are not obliged to accept, we shall have to invoice you for any costs incurred.

Components used in life-support devices or systems must be expressly authorized for such purpose! Critical components¹, may only be used in life-support devices or systems² with the express written approval of OSRAM OS.

¹ A critical component is a component used in a life-support device or system whose failure can reasonably be expected to cause the failure of that life-support device or system, or to affect its safety or effectiveness of that device or system.

² Life support devices or systems are intended (a) to be implanted in the human body, or (b) to support and/or maintain and sustain human life. If they fail, it is reasonable to assume that the health of the user may be endangered.