

Pyroelectric Detector LHi 944

Dual Element configuration including FET and optical window

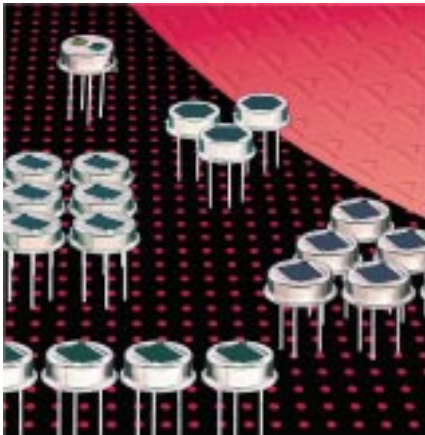

Dual Element Detector

Optimized for Light Switch Applications

The **LHi 944** pyroelectric infrared-detector series represents a special dual element design recommended for motion control with extended Field of view. They include a dual element pyroelectric ceramic with FET in source follower connection, and RF protection by additional capacitor.

The **LHi 944** is available as **TO-39** housing with standard infrared filter. It offers high responsivity with excellent common mode performance (match) and low

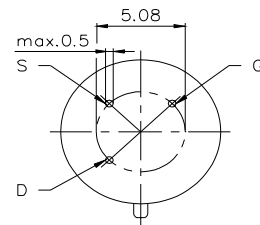
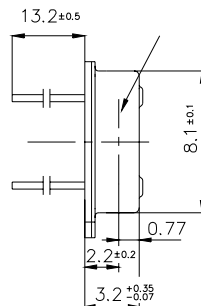
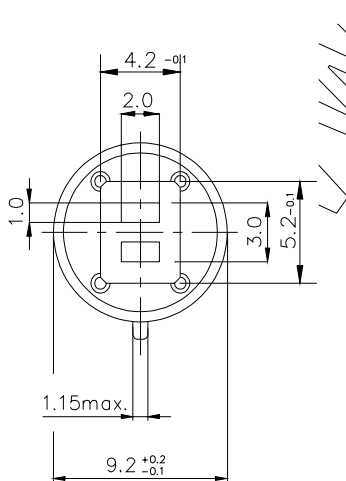
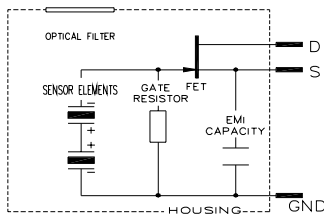
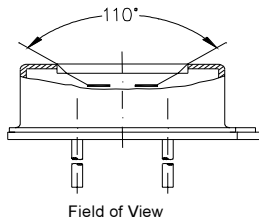

Parameters	LHi 944			
	min	typical	max	units condition
Element size	2x1		mm ²	(2 elements)
Responsivity	3 300	4000	V/W	100°C, 1 Hz
Match	1	10	%	
Noise	20	50	µVpp	25°C, 0,3...10Hz
Offset Voltage	0,2	1,55	V	R _s =47kΩ, 25°C
D*	5x10 ⁷	19x10 ⁷	cm √Hz/W	1Hz Bw, 100°C, 1 Hz
Output Impedance	5	10	kΩ	R _s =47kΩ, 25°C
Operating Voltage	2	12	V	R _s =47kΩ, 25°C
Field of View, horizontal	95		°	unobstructed
	vertical	90	°	unobstructed
Operating Temperature	40	85	°C	non permanent
Storage Temperature	-40	85	°C	non permanent

Europe:
PerkinElmer Optoelectronics
 GmbH & CoKG
 Wenzel Jaksch Str 31
 65199 Wiesbaden / Germany
 Phone +49(0)611 492 0
 Fax +49(0)611 492 170

USA:
PerkinElmer Optoelectronics
 44370 Christy Street
 Fremont, CA 94538-3180
 Phone +510 979 6500
 +800 775 6786
 Fax +510 687 1140

Asia: Dimensions in mm
PerkinElmer Optoelectronics
 47, Ayer Rajah Crescent #06-12
 Singapore 139947
 Phone +65 775 2022
 Fax +65 775 1008

Right for modification reserved / WS / 28.8.2003