



PL-2303 USB to RS-232 Bridge Controller

Product Datasheet

Document Revision 1.4

Document Release: August, 2002

www.yc-dz.com

Prolific Technology Inc.

Revision History

Revision	Description	Date
1.4	<ul style="list-style-type: none">• Add Windows CE .NET support feature	August 29, 2002
1.3	<ul style="list-style-type: none">• Buffer for upstream and downstream data flow – change from 96 to 256 bytes	August 01, 2002
1.2	<ul style="list-style-type: none">• For Chip Version H (date code 0206)• Add OS Support in Features Section• Correct default values in Table 5. Device Configuration Register• Add Suspend Current in DC Characteristics Section• Move Operating Temperature in DC Characteristics to new section	July 03, 2002

PL-2303 USB to Serial RS232 Bridge Controller

Features

- Full compliance with the USB Specification v1.1 and USB CDC v1.1
- Support the RS232 Serial interface
- Support automatic handshake mode
- Support Remote wake-up and power management
- 256 bytes buffer each for upstream and downstream data flow
- Support default ROM or external EEPROM for device configuration
- On chip USB transceiver
- On chip crystal oscillator running at 12M Hz
- Supports Windows 98/SE, ME, 2000, XP, Windows CE3.0, CE .NET, Linux, and Mac OS
- 28 Pins SOIC package

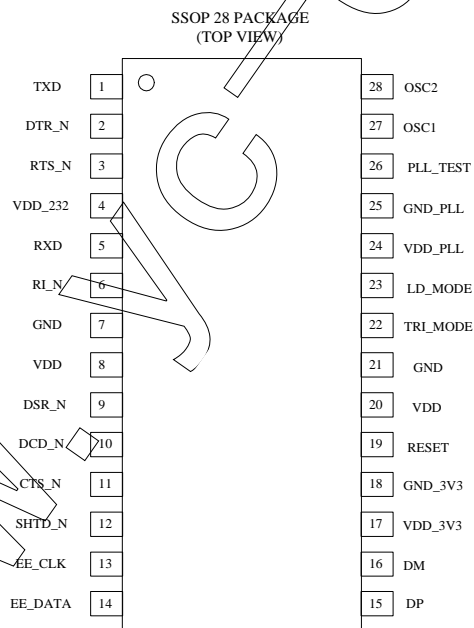

Block Diagram

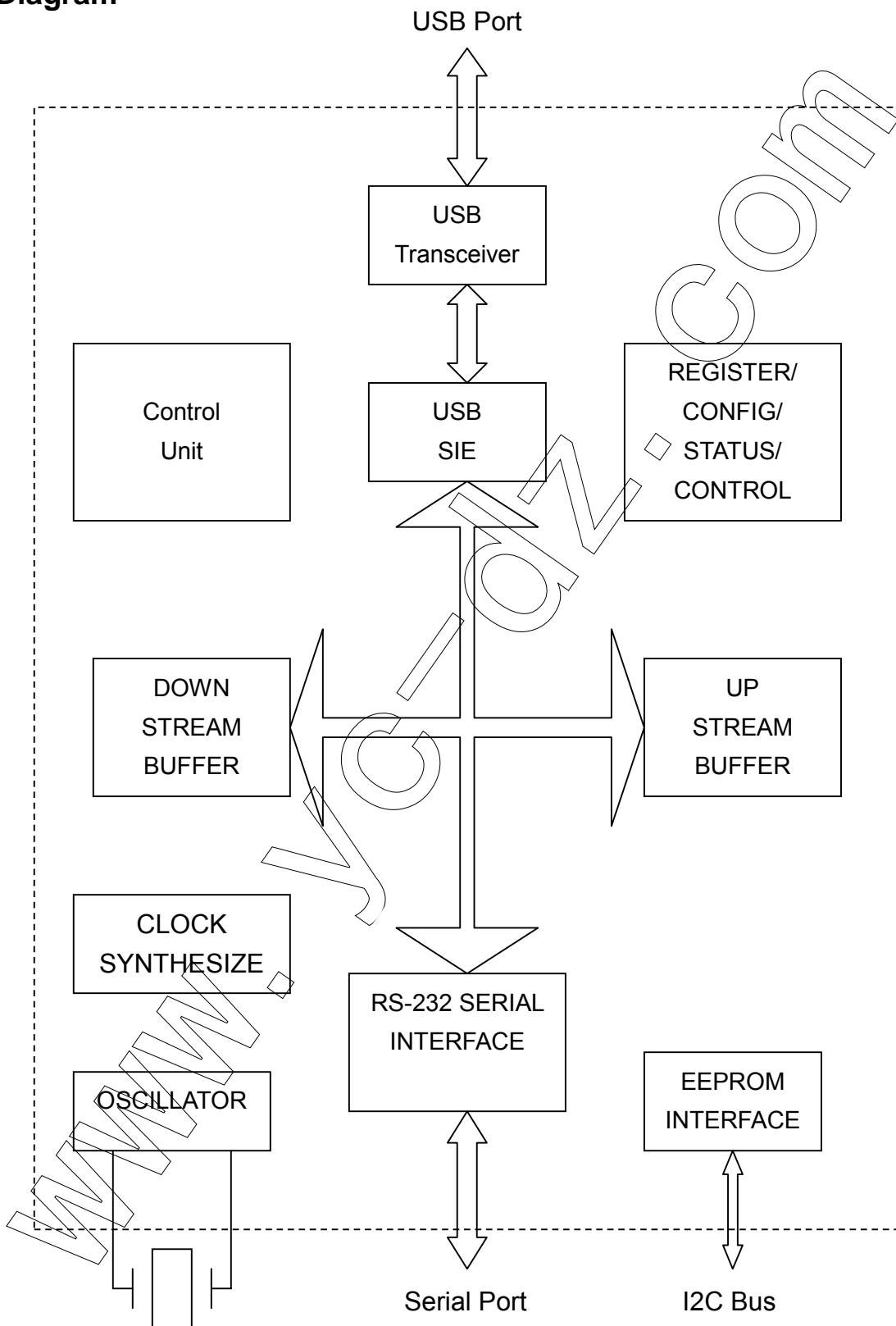

Overview

The PL-2303 operates as a bridge between one USB port and one standard RS232 Serial port. The two large on-chip buffers accommodate data flow from two different buses. The USB bulk-type data is adopted for maximum data transfer. Automatic handshake is supported at the Serial port. With these, a much higher baud rate can be achieved compared to the legacy UART controller.

This device is also compliant with USB power management and remote wakeup scheme. Only minimum power is consumed from the host during Suspend. By integrating all the function in a SOIC-28 package, this chip is suitable for cable embedding. Users just simply hook the cable into PC or hub's USB port, and then they can connect to any RS-232 devices.

Pin Description

Table 1. Pins Description

Pin No.	Name	Type	Description
1	TXD	O	Data output to Serial port
2	DTR_N	O	Data Terminal Ready, active low
3	RTS_N	O	Request To Send, active low
4	VDD_232	P	RS-232 VDD. The RS-232 output signals (Pin 1 ~ Pin 3) are designed for 5V, 3.3V or 3V operation. VDD_232 should be connected to the same power level of the RS-232 interface. (The RS-232 input signals are always 5V~3V tolerant.) Note: This document version only provides 5V DC characteristic information. Refer to future revisions for updates.
5	RXD	I	Data input from Serial Bus
6	RI_N	I	Ring Indicator, active low
7	GND	P	Ground
8	VDD	P	Power
9	DSR_N	I	Data Set Ready, active low
10	DCD_N	I	Data Carrier Detect, active low
11	CTS_N	I	Clear To Send, active low
12	SHTD_N	O	Shut Down RS232 Transceiver
13	EE_CLK	I/O	During Reset, this pin is input for simulation purpose. During normal operation, this pin is Serial ROM clock
14	EE_DATA	I/O	Serial ROM data signal
15	DP	I/O	USB DPLUS signal
16	DM	I/O	USB DMINUS signal
17	VDD_3V3	P	3.3V power for USB transceiver
18	GND_3V3	P	3.3V ground
19	RESET	I	System Reset
20	VDD	P	Power
21	GND	P	Ground

Pin No.	Name	Type	Description
22	TRI_STATE	I	Tri-State This pin is referred after reset. High: RS-232 output inactive during Suspend. Low: RS-232 output tri-state during Suspend.
23	LD_MD/ SHTD	I/O	Load Mode/SHTD This pin is input during reset. Pull high with a 220K resistor to indicate the heavy load USB device (500mA). Pull down with a 220K resistor to indicate the light load USB device (100mA). After reset, this pin becomes output. It output the inverse of SHTD_N.
24	VDD_PLL	P	5V power for PLL
25	GND_PLL	P	Ground for PLL
26	PLL_TEST	I	PLL test mode control
27	OSC1	I	Crystal oscillator input
28	OSC2	O	Crystal oscillator output

Type: **I** – Input signal **O** – Output signal **I/O** – Bi-directional signal **P** – Power/Ground

Supported Data Formats and Programmable Baud Rate Generator

The PL2303 USB-to-RS232 bridge controller supports versatile data formats and has a programmable baud rate generator. The supported data formats are shown on Table 2. The programmable baud rate generator supports baud rates up to 1.2M bps as shown in Table 3.

Table 2. Supported Data Formats

	Description
Stop bits	1 1.5 2
Parity type	None Odd Even Mark Space
Data bits	5, 6, 7, 8, or 16

Table 3. Baud Rate Setting

dwDTERate	Baud Rate
0012C000h	1228800
000E1000h	921600
00096000h	614400
00070800h	460800
00038400h	230400
0001C200h	115200
0000E100h	57600
00009600h	38400
00007080h	28800
00004B00h	19200
00003840h	14400
00002580h	9600
00001C20h	7200
000012C0h	4800
00000E10h	3600
00000960h	2400
00000708h	1800
000004B0h	1200
00000258h	600
0000012Ch	300
00000096h	150
0000004Bh	75

External EEPROM and Device Configuration

PL-2303 allows storing the configuration data in an external EEPROM. After reset, the first two bytes of EEPROM are checked. If the value is 067Bh, the EEPROM is valid and the contents of the EEPROM are loaded as the chip's default parameters. Otherwise, the chip's default setting is used. The content of EEPROM is shown in Table 4 below.

The Device Configuration Register is used to control some vendor-specific functions. The meaning of each bit in Device Configuration Register is shown in Table 5. Reserved and unused pins always set to the default value.

Table 4. EEPROM Content

Bytes	Name	Description
1:0	EECHK	When the EEPROM is programmed, these two bytes is configured as 067B. After reset, they will be checked for the value. If matched, the following information will be loaded as the default parameters.
3:2	VID	USB Vendor ID
5:4	PID	Product ID
7:6	RN	Release number (BCD)
10:8	DCR	Device Configuration Register

Table 5. Device Configuration Register

Name	Bits	Definition	Default
23	RESERVED	Reserved	0
22	TRI_OUT	RS-232 Output Tri-state: 1: RS-232 output tri-state 0: RS-232 output in output mode	0
21	RW_MODE	Remote Wakeup Mode: 0: When engages remote wakeup, the device issues disconnect signal 1: When engages remote wakeup, the device issues resume signal	1
20	WURX	Enable Wake Up Trigger on RXD: 0 – Disabled; 1 – Enable Wake Up Trigger on RXD state changes.	0
19	WUDSR	Enable Wake Up Trigger on DSR: 0 – Disabled; 1 – Enable Wake Up Trigger on DSR state changes.	0
18	WURI	Enable Wake Up Trigger on RI: 0 – Disabled; 1 – Enable Wake Up Trigger on RI state changes.	1
17	WUDCD	Enable Wake Up Trigger on DCD: 0 – Disabled; 1 – Enable Wake Up Trigger on DCD state changes.	0
16	WUCTS	Enable Wake Up Trigger on CTS: 0 – Disabled; 1 – Enable Wake Up Trigger on CTS state changes.	0
15	RESERVED	Always set to one	1
14	RESERVED	Always set to zero	0
13	RESERVED	Always set to zero	0
12	RW_INH	Remote Wake Inhibit: 1 – Inhibit the USB Remote Wakeup function 0 – Enable the USB Remote Wakeup function	0
11:6	RESERVED	Always set to zero	0
5:4	RTSM	RTS Control Method: 00b – RTS is controlled by ControlBitMap. Signal is active low; 01 – RTS is controlled by ControlBitMap. Signal is active high; 10 – Drive RTS active when Downstream Data Buffer is NOT EMPTY; otherwise Drive RTS inactive. 11 – Drive RTS inactive when Downstream Data Buffer is NOT EMPTY; otherwise Drive RTS active.	0
3:1	RESERVED	Always set to zero	0
0	RSPDM	RS-232 Transceiver Shut-Down Mode: 1: Shut down the transceiver when USB SUSPEND is engaged 0: Do not shut down the transceiver even when USB SUSPEND is engaged	1

Electrical Characteristics

Absolute Maximum Ratings

Item	Ratings
Power Supply Voltage	-0.3 to 6.0 V
Input Voltage	-0.3 to VDD+0.3 V
Output Voltage	-0.3 to VDD+0.3 V
Storage Temperature	-55 to 150 °C

DC Characteristics

Parameter	Symbol	Min	Typ	Max	Units
Power Supply Current	I _{DD}	0.5	19	24	mA
Input Voltage					
Low	V _{IL}	--	--	0.3* V _{DD}	V
High	V _{IH}	0.7* V _{DD}	--	--	V
Output Voltage					
Low	V _{OL}	--	--	0.4	V
High	V _{OH}	3.5	--	--	V
Schmitt Trigger Threshold Voltage* ¹					
Negative going	V _{t-}	--	1.10	--	V
Positive going	V _{t+}	--	1.87	--	V
Output Voltage, 3.3V* ²					
Low	V _{OL}	--	--	0.4	V
High	V _{OH}	2.4	--	--	V
Input Leakage Current	I _L	-1	--	1	uA
Tri-state Leakage Current	I _{OZ}	-10	--	10	uA
Input Capacitance	C _{IN}	--	3	--	Pf
Output Capacitance	C _{OUT}	--	3	--	Pf
Bi-directional Buffer Capacitance	C _{BIB}	--	3	--	Pf
Operating Voltage Range	--	4.75	5	5.25	V
Suspend Current	I _{SUS}	--	400	490	uA

*1. RS232 pins RXD_I, RI_I, DSR_I, DCD_I, CTS_I are 5V TTL Schmitt Trigger inputs.

*2. RS232 pins TXD_N, DTR_N, RTS_N are 3.3V tri-state outputs.

Temperature Characteristics

Parameter	Symbol	Min	Typ	Max	Units
Operating Temperature	--	-40	--	85	°C
Junction Operation Temperature	T _J	0	25	115	°C

USB Transceiver Characteristics

Parameter	Symbol	Min	Typ	Max	Units
Rise and Fall Times: (10%—90%)	T_R	4	8	15	ns
(90%—10%)	T_F	4	8	15	ns
Cross Point	V_{CR}	1.3	--	2.0	V
Output Impedance	R_D	23	28	33	ohm
High Level Output	V_{OH}	2.8	--	--	V
Low Level Output	V_{OL}	--	--	0.7	V
High Level Input	V_{IH}	2.0	--	--	V
Low Level Input	V_{IL}	--	--	0.8	V

- C_L : 50pf

Clock Characteristics

Parameter	Min	Typ	Max	Units
Frequency of Operation	11.976	12.000	12.024	MHz
Clock Period	83.1	83.3	83.5	ns
Duty Cycle	45	50	55	%

Package Dimensions (28-Pin SSOP)

Symbol	Millimeters			Inch		
	Min	Nom	Max	Min	Nom	Max
b	0.22		0.38	0.009		0.015
E	7.40	7.80	8.20	0.291	0.307	0.323
E1	5.00	5.30	5.60	0.197	0.209	0.220
L	0.55	0.75	0.95	0.021	0.030	0.037
R1	0.09			0.004		
D	9.9	10.2	10.5	0.390	0.402	0.413
A			2.0			0.079
e		0.65			0.0256	
L1		1.25			0.050	
A1	0.05			0.020		
A2	1.65	1.75	1.85	0.065	0.069	0.073

Outline Diagram

