

Pyroelectric Detector LHi 1548

Four Elements, Two reverse Polarity FET Outputs

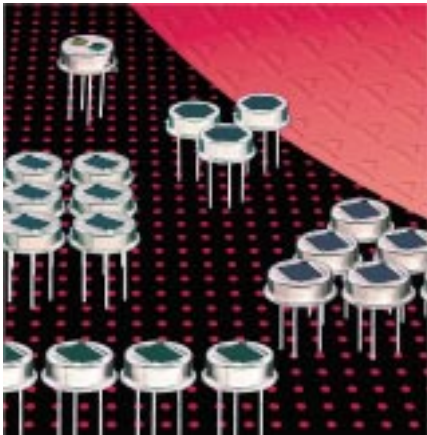

Twin element design

Designed for High End Alarm applications

The **LHi 1548** pyroelectric infrared detector is designed for high end PIR alarm applications. It includes a twin type pyroelectric ceramic with 4 sensitive elements connected to two FET source follower circuits. Thus it provides for dual channel output. The channels are of inverse polarity.

The **LHi 1548** detector is available in **TO-5** housing with standard infrared filter. It offers excellent common mode performance (match) and low noise

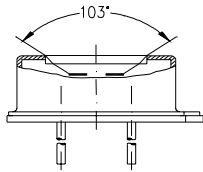

Field of View

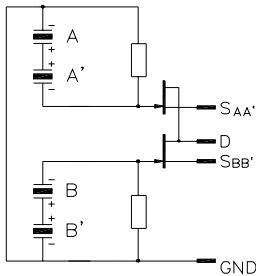

Parameters	LHi 1548			units	condition
	min	typical	max		
Element size		0,953		mm ²	(4 elements)
Responsivity	4200	5000		V/W	100°C, 1 Hz
Match		1	15	%	
Noise		30	75	µVpp	25°C, 0,3...10Hz
Offset Voltage	0,2		1,55	V	R _s =47kΩ, 25°C
D*	3,5x10 ⁻⁷	11x10 ⁻⁷		cm √Hz/W	1Hz Bw, 100°C, 1 Hz
Output Impedance		5	10	kΩ	R _s =47kΩ, 25°C
Operating Voltage	2		12	V	R _s =47kΩ, 25°C
Field of View, horizontal		103°			unobstructed
Field of View, vertical		96°			unobstructed
Operating Temperature	-40		85	°C	non permanent
Storage Temperature	-40		85	°C	non permanent

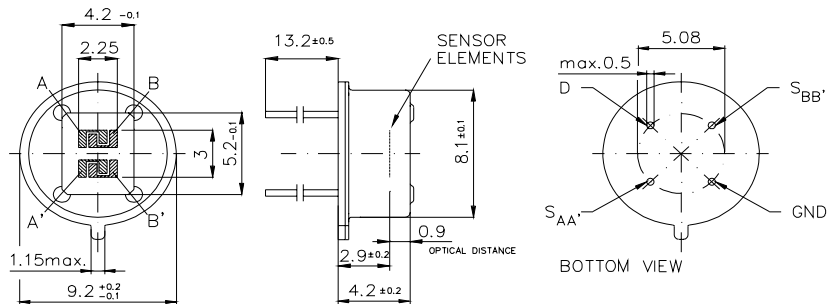

Europe:
PerkinElmer Optoelectronics
 GmbH & CoKG
 Wenzel Jaksch Str 31
 65199 Wiesbaden / Germany
 Phone +49(0)611 492 0
 Fax +49(0)611 492 170

USA:
PerkinElmer Optoelectronics
 44370 Christy Street
 Fremont, CA 94538-3180
 Phone +510 979 6500
 +800 775 6786
 Fax +510 687 1140

Asia: Dimensions in mm
PerkinElmer Optoelectronics
 47, Ayer Rajah Crescent #06-12
 Singapore 139947
 Phone +65 775 2022
 Fax +65 775 1008



Right for modification reserved / WS / 28.8.2003