

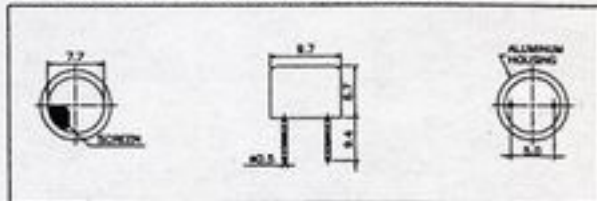

Dimensions: Dimensions are in mm



Impedance/Phase Angle vs. Frequency

Tested under 1Vrms Oscillation Level

400SR100 Impedance _____

400SR100 Phase _____

400ST100 Impedance _____

400ST100 Phase _____

Specification

400ST100	Transmitter
400SR100	Receiver
Center Frequency	40.0±1.0Khz
Bandwidth (-6dB)	400ST100 2.5Khz
	400SR100 3.0Khz
Transmitting Sound Pressure Level	112dB min.
at 40.0Khz; 0dB re 0.0002μbar per 10Vrms at 30cm	
Receiving Sensitivity	-70dB min.
at 40.0Khz 0dB = 1 volt/μbar	
Capacitance at 1Khz	±20% 1900 pF
Max. Driving Voltage (cont.)	10Vrms
Total Beam Angle	-6dB 72° typical
Operation Temperature	-30 to 80°C
Storage Temperature	-40 to 85°C

All specification taken typical at 25°C
Closer frequency tolerance can be supplied upon request.

Model available:

1	400ST/R100	Aluminum Housing
2	400ST/R10B	Black Al. Housing
3	400ST/R10P	Plastic Housing

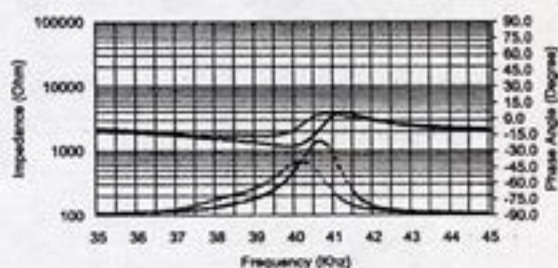

Sensitivity/Sound Pressure Level

Tested under 10Vrms @30cm

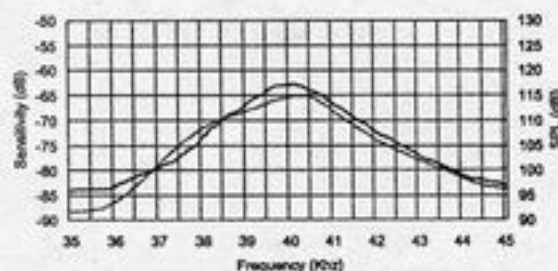

Beam Angle: Tested at 40.0Khz frequency

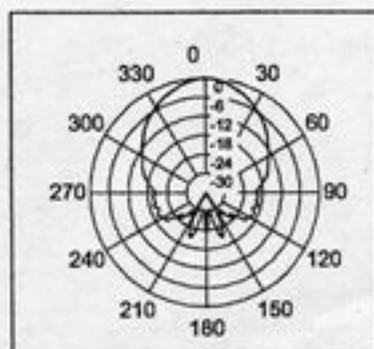

400SR100 Receiver

400ST100 Transmitter

Sensitivity Variation vs. Loaded Resistor

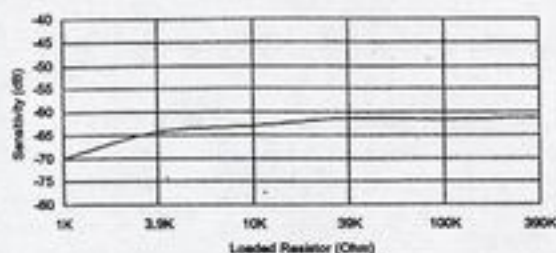

SPL Variation vs. Driving Voltage

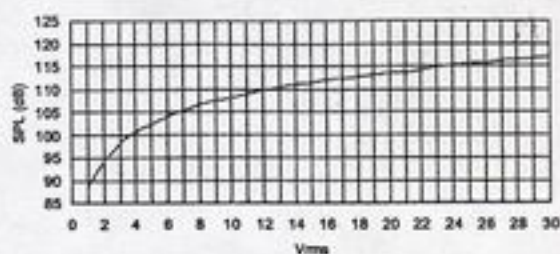

Center Frequency Shift vs. Loaded Resistor

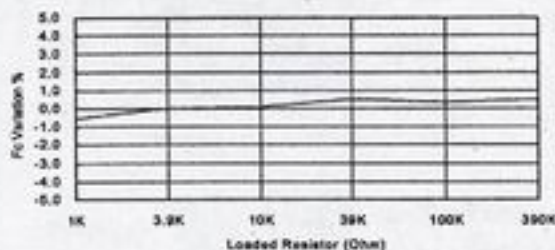

Center Frequency Shift vs. Driving Voltage

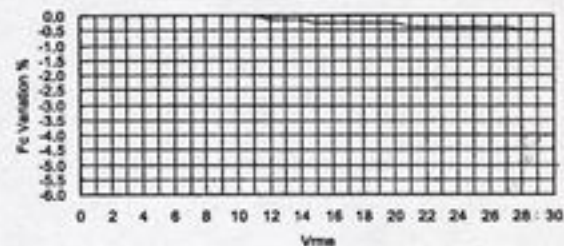

Sensitivity Variation vs. Temperature

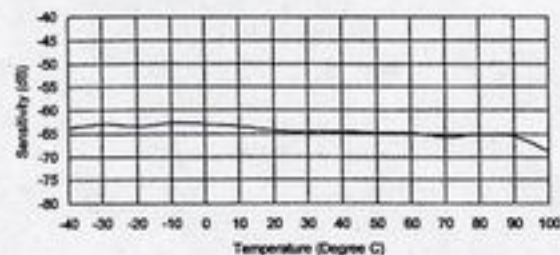

SPL Variation vs. Temperature

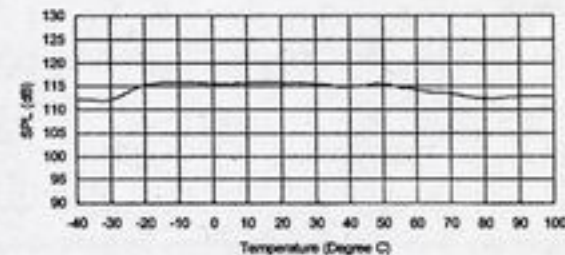

Center Frequency Shift vs. Temperature

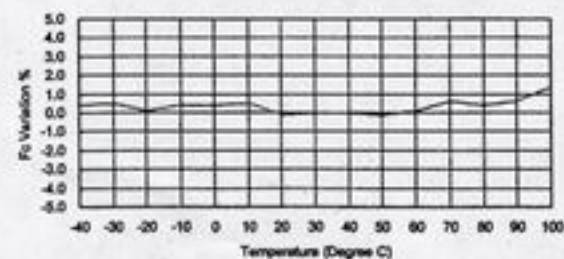

Center Frequency Shift vs. Temperature

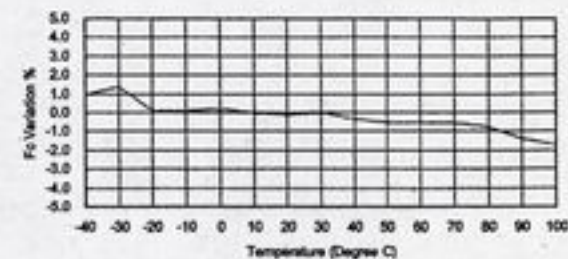

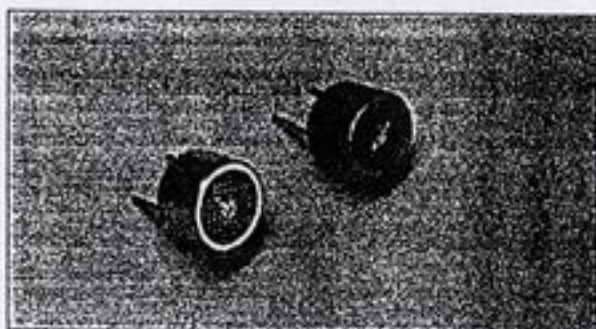

Dimensions: dimensions are in mm

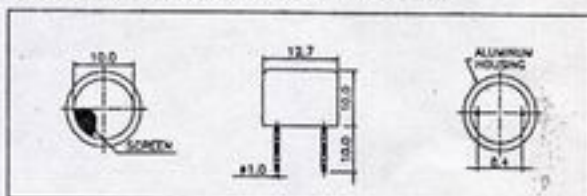

Specification

400ST120	Transmitter
400SR120	Receiver
Center Frequency	40.0±1.0Khz
Bandwidth (-6dB)	400ST120 2.0Khz 400SR120 2.0Khz
Transmitting Sound Pressure Level	115dB min.
at 40.0Khz; 0dB re 0.0002μbar per 10Vrms at 30cm	
Receiving Sensitivity	-67dB min.
at 40.0Khz 0dB = 1 volt/μbar	
Capacitance at 1Khz	±20% 2400 pF
Max. Driving Voltage (cont.)	20Vrms
Total Beam Angle	-6dB 85° typical
Operation Temperature	-30 to 80°C
Storage Temperature	-40 to 85°C

All specification taken typical at 25°C
Closer frequency tolerance can be supplied upon request.

Model available:

1	400ST/R120	Aluminum Housing
2	400ST/R12B	Black Al. Housing

Impedance/Phase Angle vs. Frequency

Tested under 1Vrms Oscillation Level

- 400SR120 Impedance _____
- 400SR120 Phase _____
- 400ST120 Impedance _____
- 400ST120 Phase _____

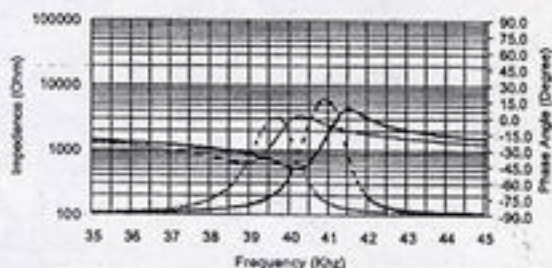

Sensitivity/Sound Pressure Level

Tested under 10Vrms @30cm

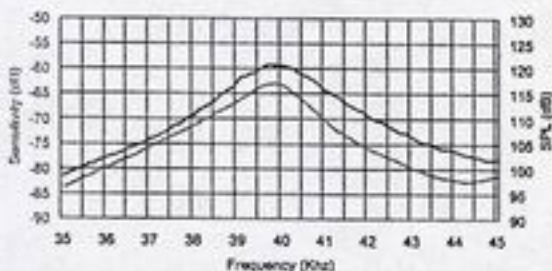

Beam Angle: Tested at 40.0Khz frequency

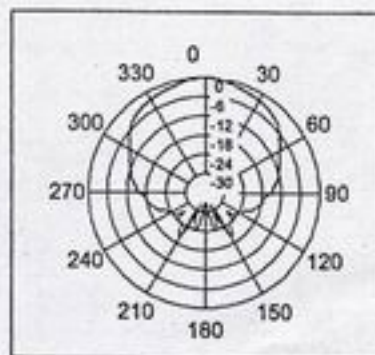

400SR120 Receiver

400ST120 Transmitter

Sensitivity Variation vs. Loaded Resistor

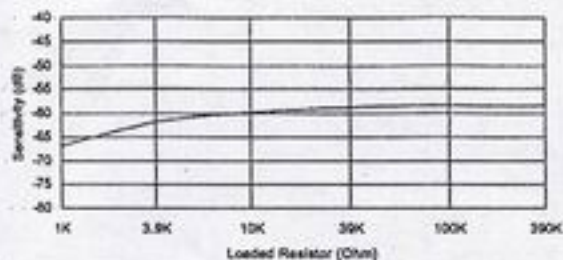

SPL Variation vs. Driving Voltage

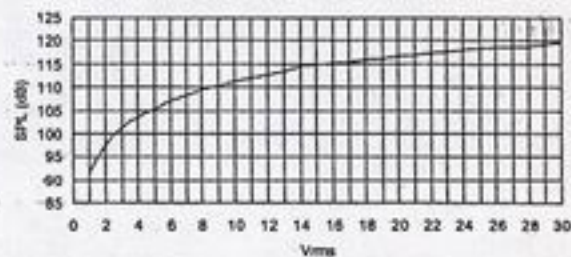

Center Frequency Shift vs. Loaded Resistor

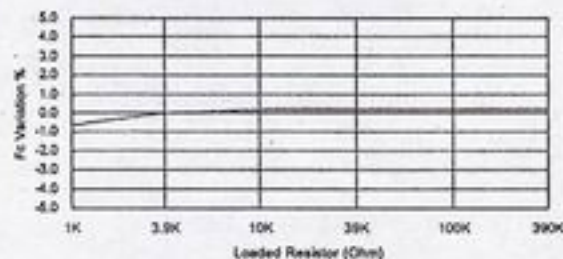

Center Frequency Shift vs. Driving Voltage

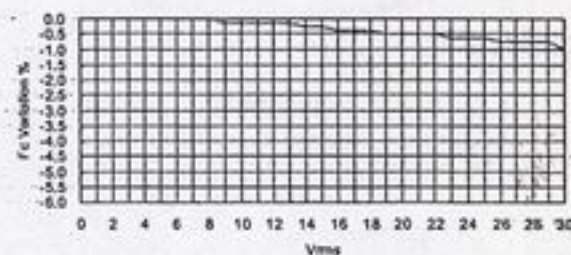

Sensitivity Variation vs. Temperature

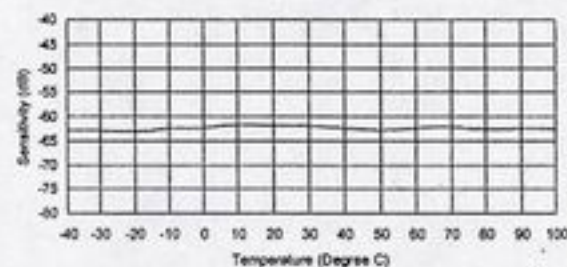

SPL Variation vs. Temperature

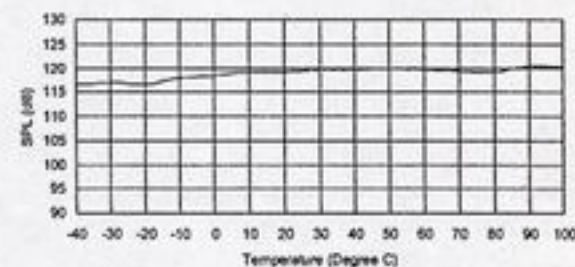

Center Frequency Shift vs. Temperature

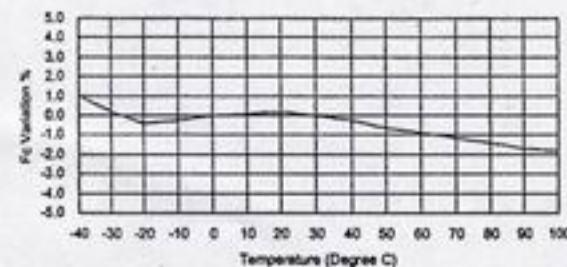

Center Frequency Shift vs. Temperature

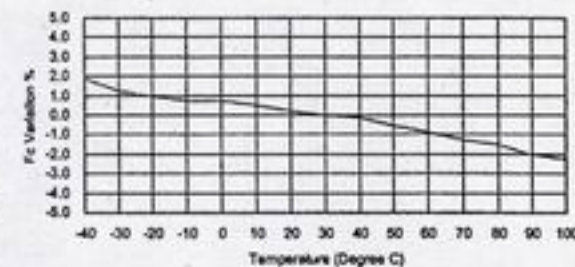

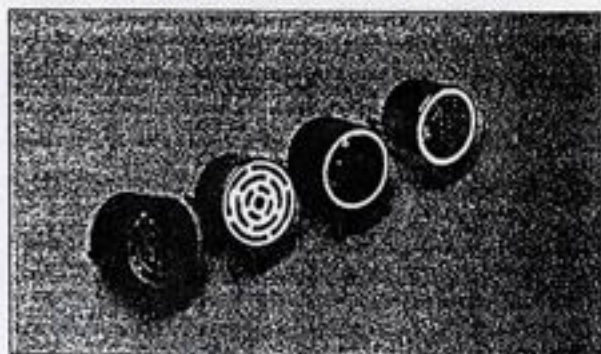

Dimensions: dimensions are in mm

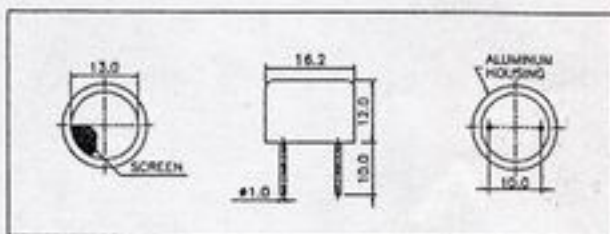

Specification

400ST160	Transmitter
400SR160	Receiver
Center Frequency	40.0±1.0Khz
Bandwidth (-6dB)	400ST160 2.0Khz
	400SR160 2.5Khz
Transmitting Sound Pressure Level	120dB min.
at 40.0Khz; 0dB re 0.0002μbar per 10Vrms at 30cm	
Receiving Sensitivity	-65dB min.
at 40.0Khz 0dB = 1 volt/μbar	
Capacitance at 1Khz	±20% 2400 pF
Max. Driving Voltage (cont.)	20Vrms
Total Beam Angle	-6dB 55° typical
Operation Temperature	-30 to 80°C
Storage Temperature	-40 to 85°C

All specification taken typical at 25°C
Closer frequency tolerance can be supplied upon request.

Models available:

1	400ST/R160	Aluminum Housing
2	400ST/R16B	Black Al. Housing
2	400ST/R10P	Plastic Housing
3	400ST/R16F	Al. Housing w/Solid Grid

Impedance/Phase Angle vs. Frequency

Tested under 1Vrms Oscillation Level

400SR160 Impedance	_____
400SR160 Phase	_____
400ST160 Impedance	_____
400ST160 Phase	_____

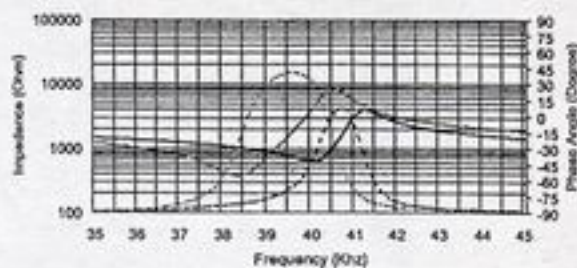

Sensitivity/Sound Pressure Level

Tested under 10Vrms @30cm

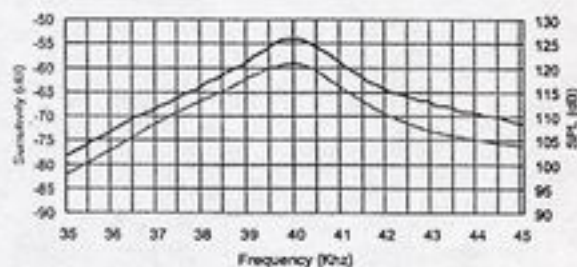

Beam Angle: Tested at 40.0Khz frequency

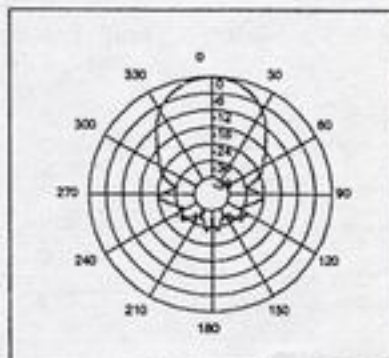

400SR160 Receiver

400ST160 Transmitter

Sensitivity Variation vs. Loaded Resistor

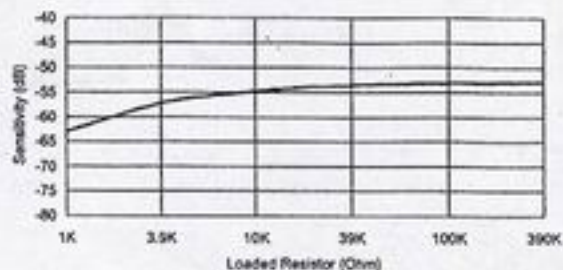

SPL Variation vs. Driving Voltage

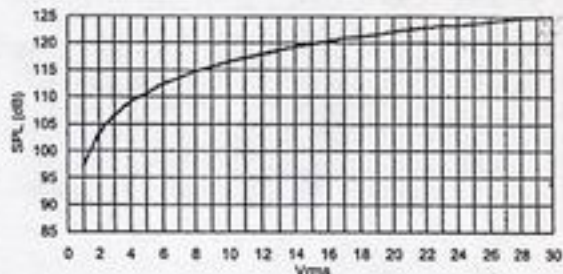

Center Frequency Shift vs. Loaded Resistor

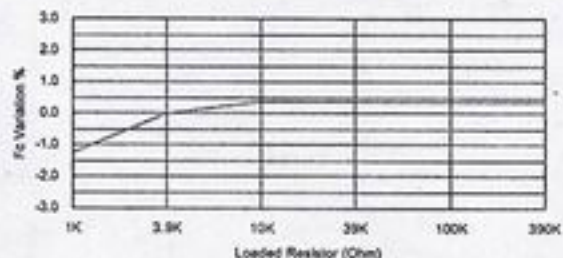

Center Frequency Shift vs. Driving Voltage

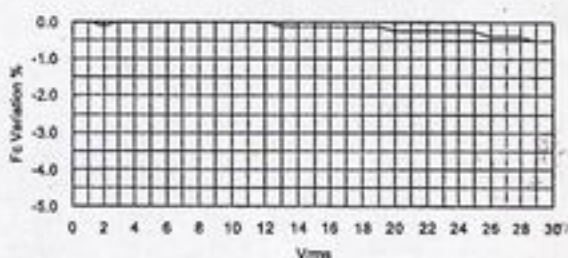

Sensitivity Variation vs. Temperature

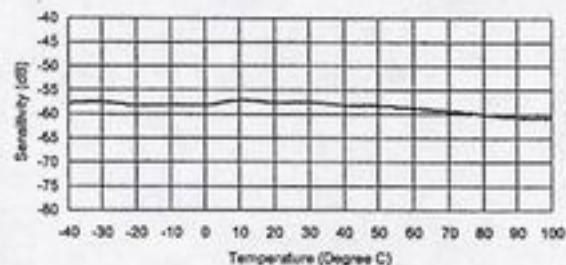

SPL Variation vs. Temperature

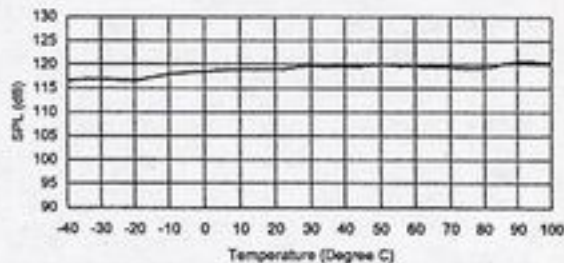

Center Frequency Shift vs. Temperature

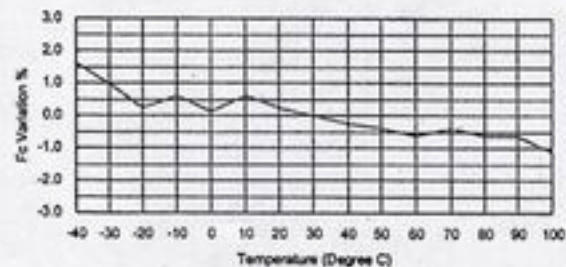

Center Frequency Shift vs. Temperature

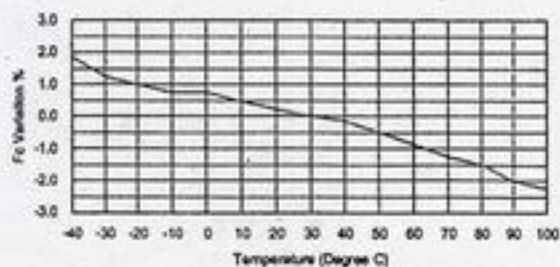

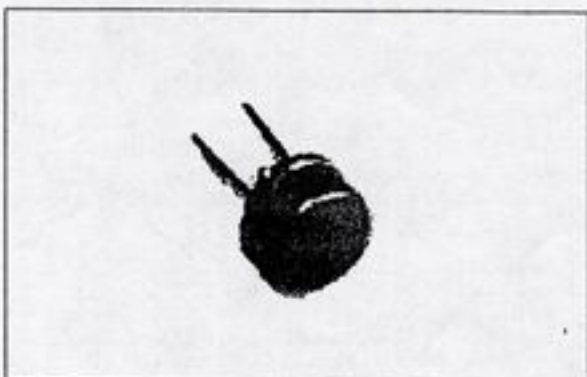

Dimensions: dimensions are in mm

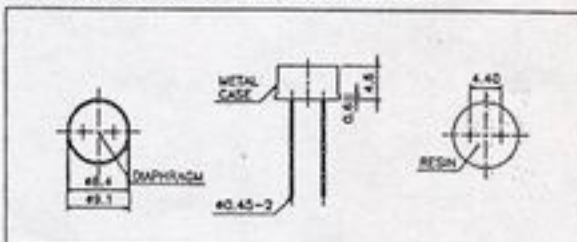

Impedance/Phase Angle vs. Frequency

Tested under 1Vrms Oscillation Level

400ER080 Impedance _____

400ER080 Phase _____

400ET080 Impedance _____

400ET080 Phase _____

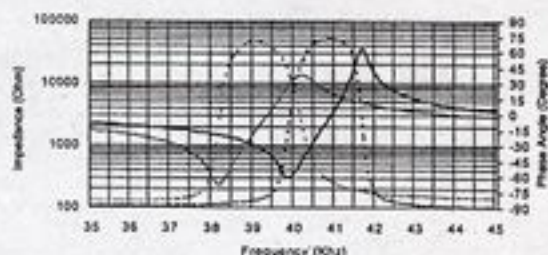

Specification

400ET080	Transmitter
400ER080	Receiver
Center Frequency	40.0±3.0Khz
Bandwidth (-6dB)	400ET080 1.5Khz
	400ER080 2.0Khz
Transmitting Sound Pressure Level	100dB min.
at 40.0Khz; 0dB re 0.0002μbar per 10Vrms at 30cm	
Receiving Sensitivity	-80dB min.
at 40.0Khz 0dB = 1 volt/μbar	
Capacitance at 1Khz	±20% 1700 pF
Max. Driving Voltage (cont.)	15Vrms
Total Beam Angle	-6dB 125° typical
Operation Temperature	-30 to 80°C
Storage Temperature	-40 to 85°C

All specification taken typical at 25°C
Closer frequency tolerance can be supplied upon request.

Model available:

1	400ET/R080	Plated Metal Housing
---	------------	----------------------

Sensitivity/Sound Pressure Level

Tested under 10Vrms @30cm

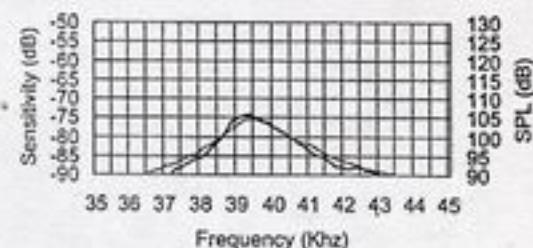

Beam Angle: Tested at 40.0Khz frequency

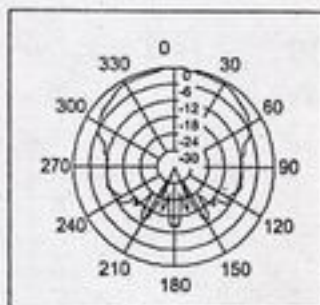

400ER080 Receiver

400ET080 Transmitter

Sensitivity Variation vs. Loaded Resistor

SPL Variation vs. Driving Voltage

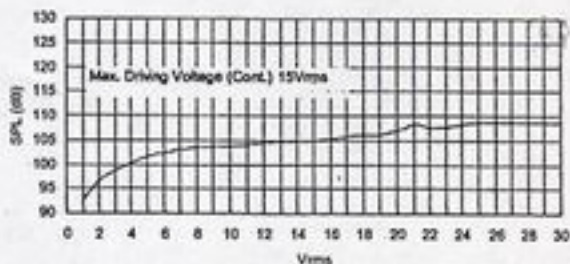
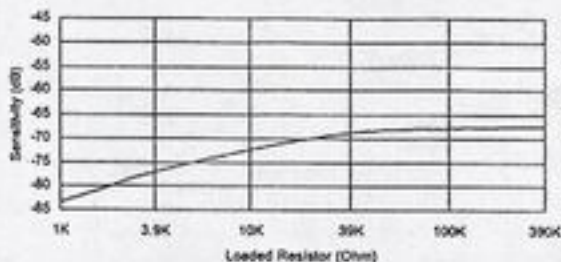

Center Frequency Shift vs. Loaded Resistor

Center Frequency Shift vs. Driving Voltage

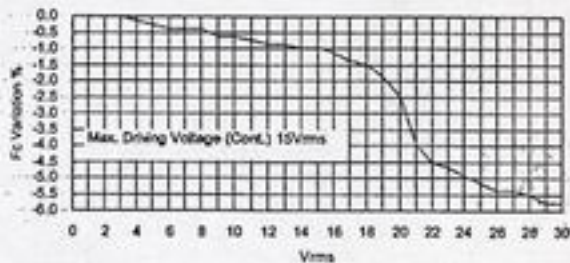
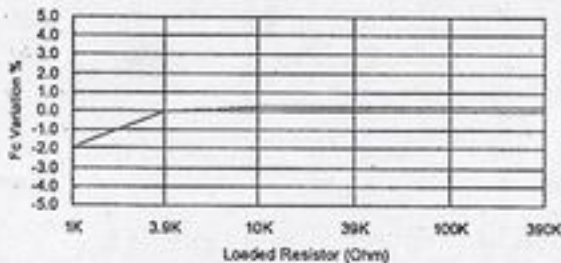

Sensitivity Variation vs. Temperature

SPL Variation vs. Temperature

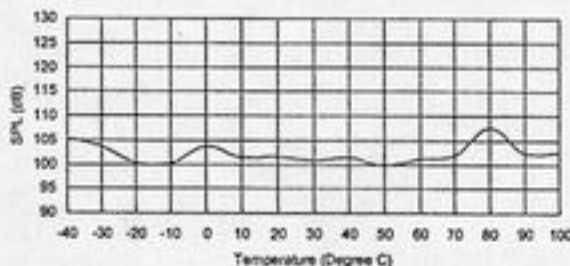
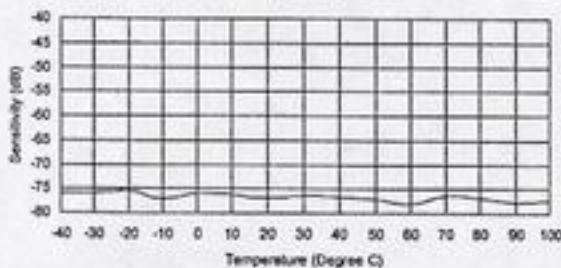

Center Frequency Shift vs. Temperature

Center Frequency Shift vs. Temperature

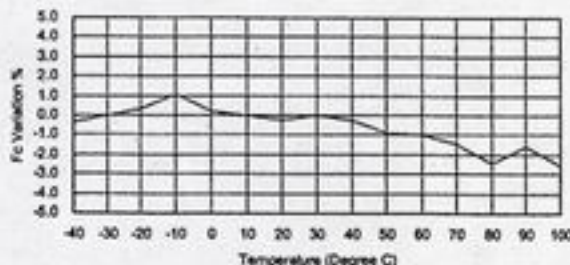
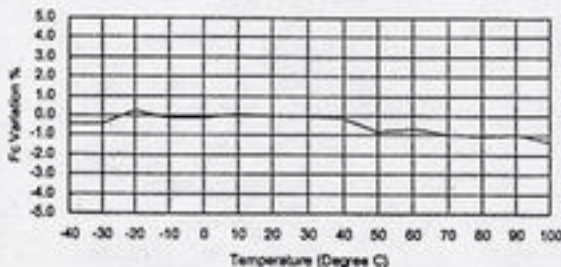

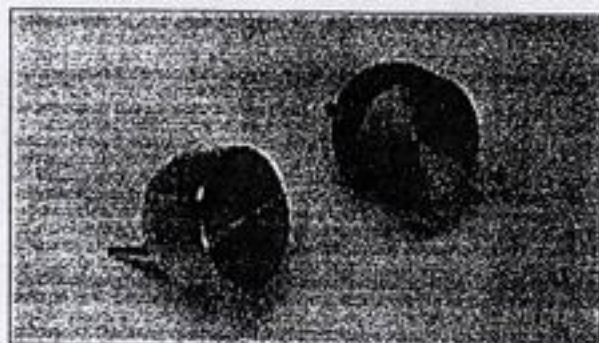

Specification

400ET180	Transmitter
400ER180	Receiver
Center Frequency	40.0±1.0Khz
Bandwidth (-6dB)	400ET180 1.5Khz 400ER180 1.5Khz
Transmitting Sound Pressure Level	115dB min.
at 40.0Khz; 0dB re 0.0002μbar per 10Vrms at 30cm	
Receiving Sensitivity	-70dB min.
at 40.0Khz 0dB = 1 volt/μbar	
Capacitance at 1Khz ±20%	2400 pF
Max. Driving Voltage (cont.)	15Vrms
Total Beam Angle	-6dB 30° typical
Operation Temperature	-30 to 80°C
Storage Temperature	-40 to 85°C

All specification taken typical at 25°C
Closer frequency tolerance can be supplied upon request.

Model available:

1	400ET/R180	Aluminum Housing
2	400ET/R18B	Black Alum. Housing

Dimensions: dimensions are in mm

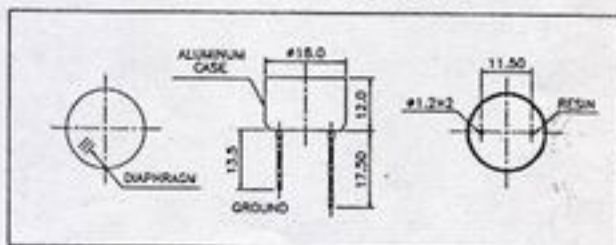

Impedance/Phase Angle vs. Frequency

Tested under 1Vrms Oscillation Level

400ER180 Impedance	_____
400ER180 Phase	_____
400ET180 Impedance	_____
400ET180 Phase	_____

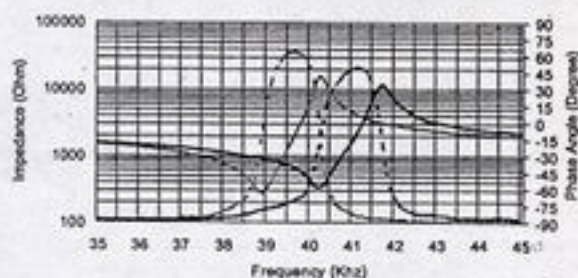

Sensitivity/Sound Pressure Level

Tested under 10Vrms @30cm

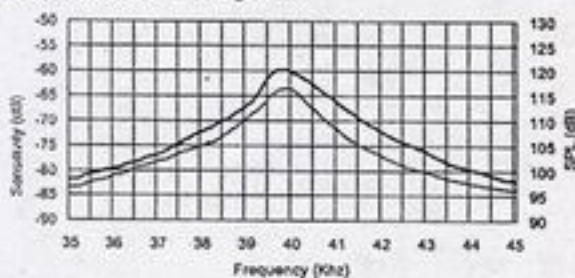

Beam Angle: Tested at 40.0Khz frequency

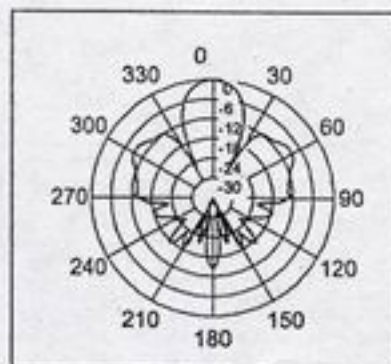

400ER180 Receiver

400ET180 Transmitter

Sensitivity Variation vs. Loaded Resistor

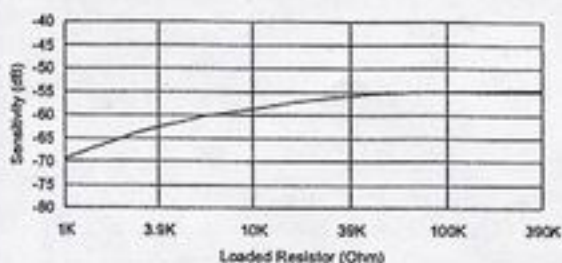

SPL Variation vs. Driving Voltage

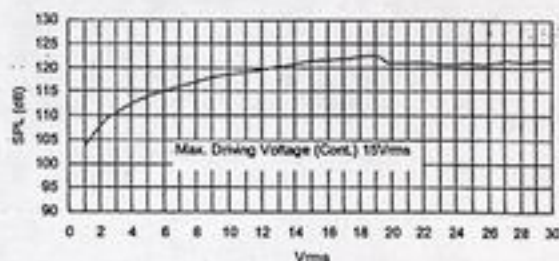

Center Frequency Shift vs. Loaded Resistor

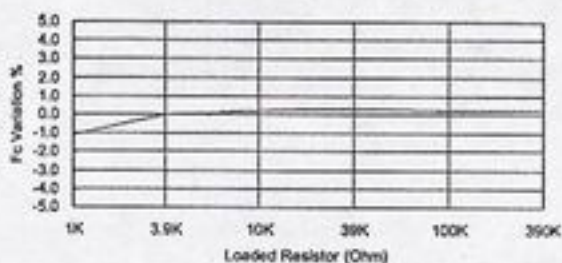

Center Frequency Shift vs. Driving Voltage

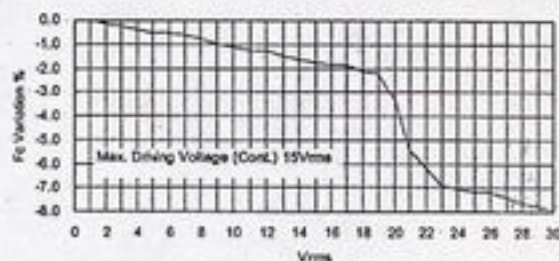

Sensitivity Variation vs. Temperature

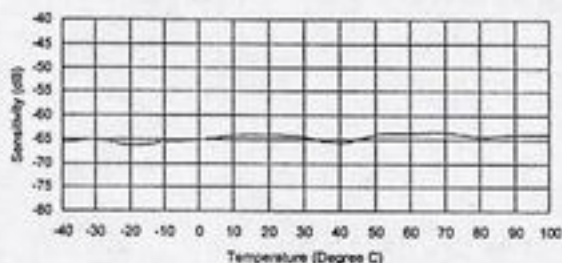

SPL Variation vs. Temperature

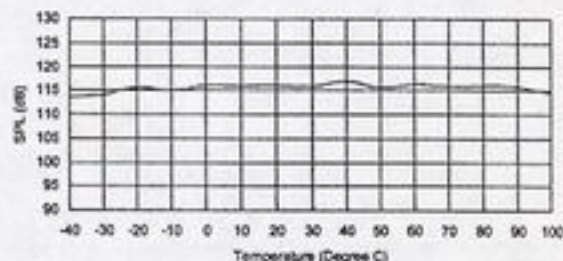

Center Frequency Shift vs. Temperature

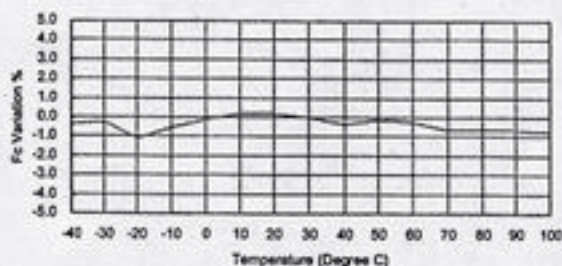

Center Frequency Shift vs. Temperature

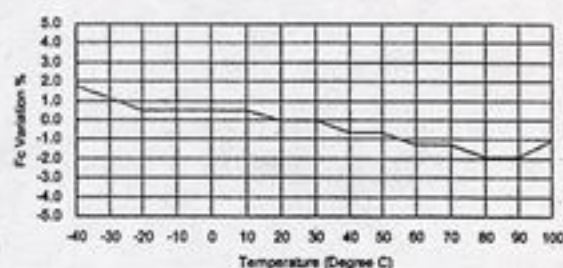

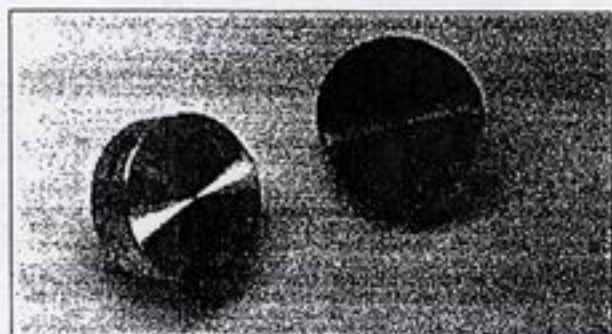

Dimensions: dimensions are in mm

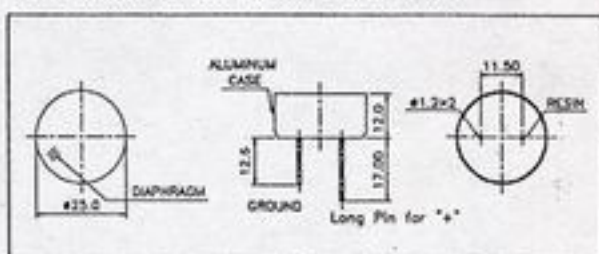

Specification

400ET250	Transmitter
400ER250	Receiver
Center Frequency	40.0±1.0Khz
Bandwidth (-6dB)	400ET250 1.0Khz
	400ER250 1.0Khz
Transmitting Sound Pressure Level	115dB min.
at 40.0Khz; 0dB re 0.0002μbar per 10Vrms at 30cm	
Receiving Sensitivity	-70dB min.
at 40.0Khz 0dB = 1 volt/μbar	
Capacitance at 1Khz	±20% 2400 pF
Max. Driving Voltage (cont.)	20Vrms
Total Beam Angle	-6dB 30° typical
Operation Temperature	-30 to 80°C
Storage Temperature	-40 to 85°C

All specification taken typical at 25°C
Closer frequency tolerance can be supplied upon request.

Model available:

1	400ET/R250	Aluminum Housing
2	400ET/R25B	Black Alum. Housing

Impedance/Phase Angle vs. Frequency

Tested under 1Vrms Oscillation Level

400ER250 Impedance	_____
400ER250 Phase	_____
400ET250 Impedance	_____
400ET250 Phase	_____

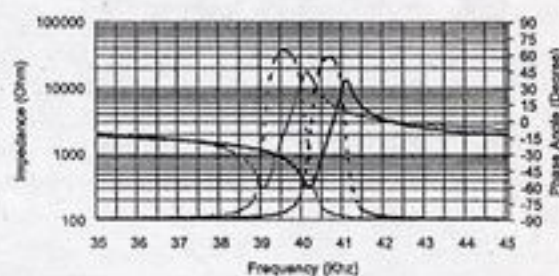

Sensitivity/Sound Pressure Level

Tested under 10Vrms @30cm

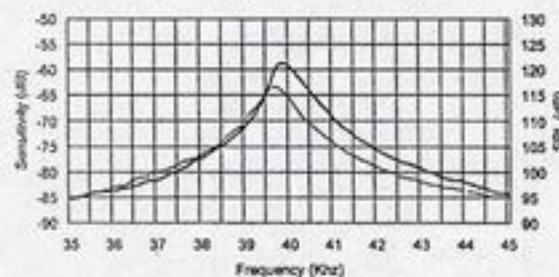

Beam Angle: Tested at 40.0Khz frequency

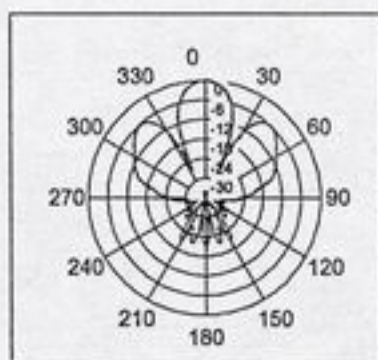

400ER250 Receiver

400ET250 Transmitter

Sensitivity Variation vs. Loaded Resistor

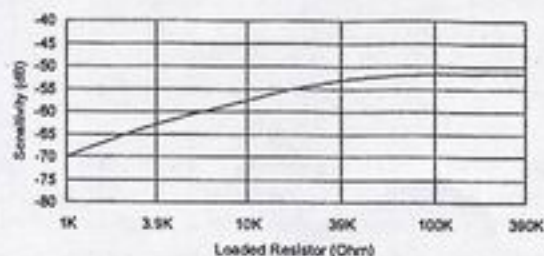

SPL Variation vs. Driving Voltage

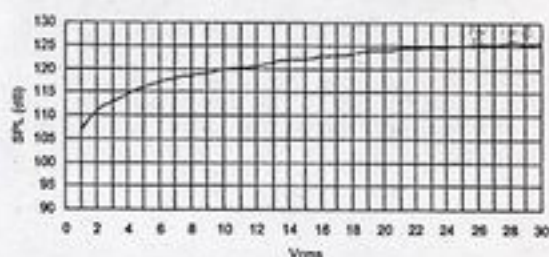

Center Frequency Shift vs. Loaded Resistor

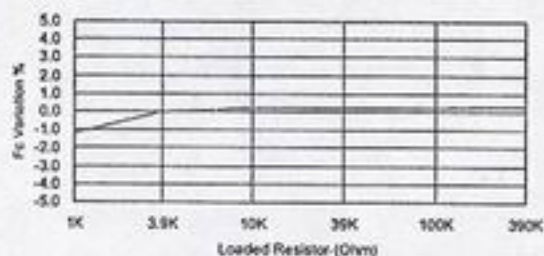

Center Frequency Shift vs. Driving Voltage

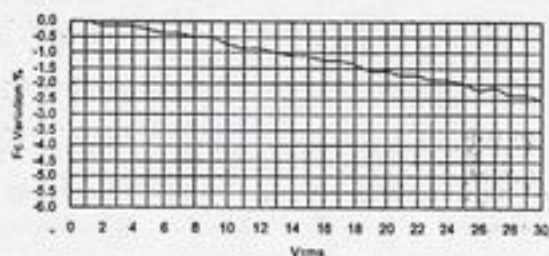

Sensitivity Variation vs. Temperature

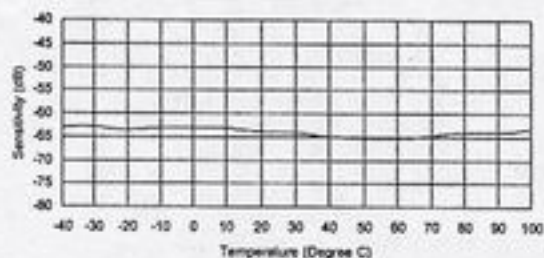

SPL Variation vs. Temperature

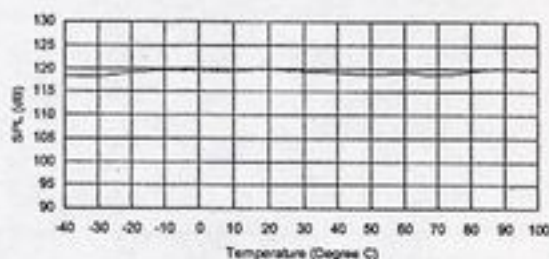

Center Frequency Shift vs. Temperature

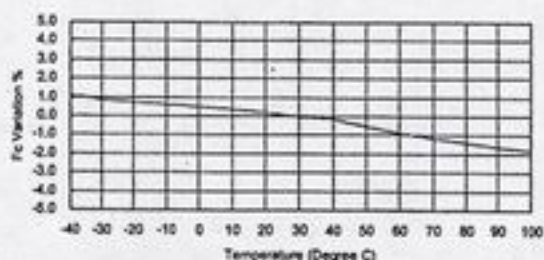

Center Frequency Shift vs. Temperature

