

# PNA4702M

## Photodiode with amplifier functions

For infrared remote control systems

### ■ Features

- Center frequency  $f_0$  : 38 kHz
- Operating supply voltage  $V_{CC}$  : 3.3 V(typ.)
- Adoption of visible light cutoff resin

### ■ Absolute Maximum Ratings $T_a = 25^\circ\text{C}$

Parameter	Symbol	Rating	Unit
Operating supply voltage	$V_{CC}$	-0.5 to +5	V
Power dissipation	$P_D$	200	mW
Operating ambient temperature	$T_{opr}$	-15 to +70	$^\circ\text{C}$
Storage temperature	$T_{stg}$	-40 to +100	$^\circ\text{C}$
Soldering temperature *	$T_{sol}$	260	$^\circ\text{C}$

Note) \*: Less than 5 s

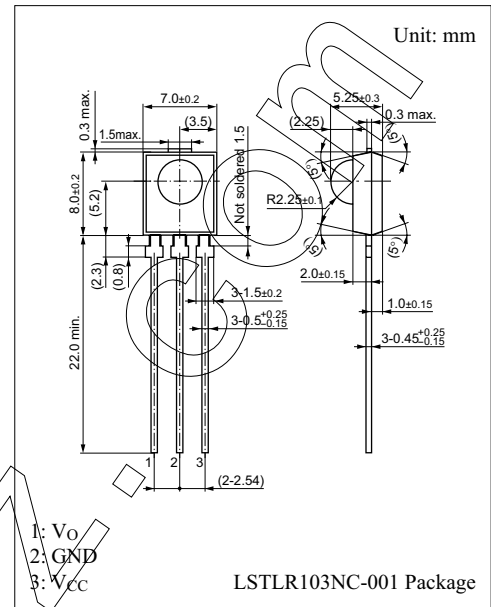

### ■ Electrical Characteristics $T_a = 25^\circ\text{C} \pm 3^\circ\text{C}$ , $V_{CC} = 3.3\text{ V}$

Parameter	Symbol	Conditions	Min	Typ	Max	Unit
Operating supply voltage	$V_{CC}$		2.7	3.3	3.6	V
Output voltage low-level *2	$V_{OL}$	$L \leq 7\text{ m}$ , $I_{OL} = 400\ \mu\text{A}$	—	0.1	0.3	V
Output voltage high-level	$V_{OH}$	No signal condition	3.1	3.3	$V_{CC}$	V
Supply current	$I_{CC}$		0.6	0.8	1.0	mA
Maximum reception distance	$L_{max}$		7.0	—	—	m
Pulse width low-level *1	$T_{WL}$	$L \approx 0.1\text{ m to } 7\text{ m}$ , 16 pulse	200	400	600	$\mu\text{s}$
Pulse width high-level *1	$T_{WH}$					
Center frequency	$f_0$		—	38.0	—	kHz

Note) 1. Measuring methods are based on JAPANESE INDUSTRIAL STANDARD JIS C 7031 measuring methods for diodes.

2. \*1: Burst wave form Figure 1

\*2: Constant wave form Figure 2

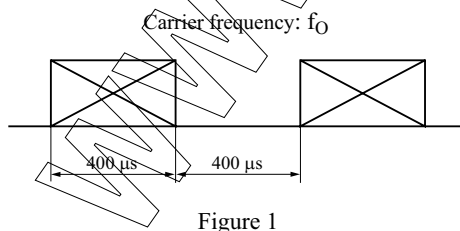

Figure 1

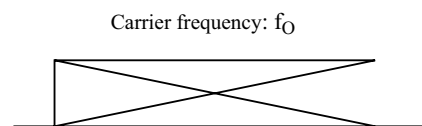
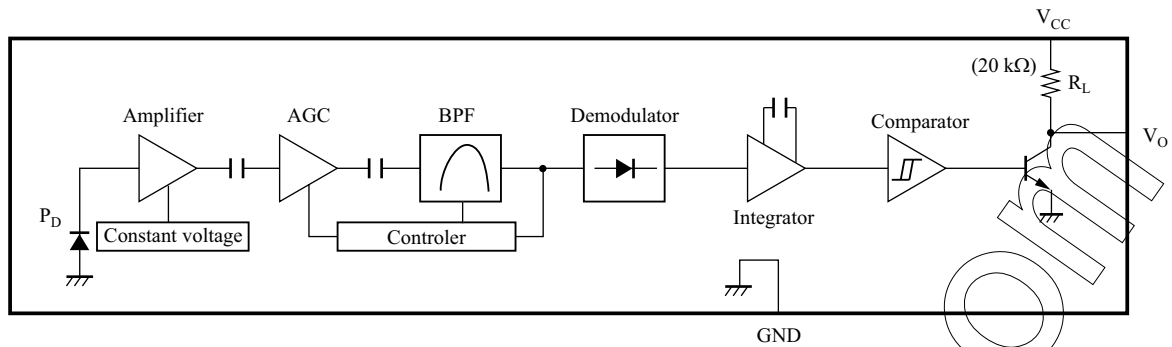
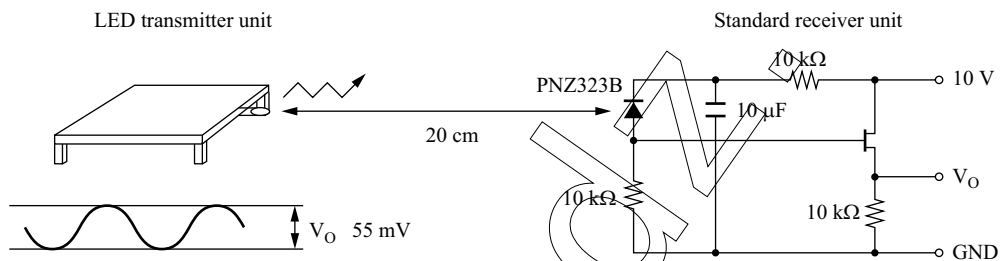

Figure 2

■ Block Diagram



■ Panasonic Transmitter Specifications



1. The output of the LED transmitter unit is adjusted so that the output standard receiver unit,  $V_O$  may be 55 mV when transmitting waves (duty = 50%) are output from the transmitter unit, where the sensitivity to infrared emitters (SIR) of PNZ323B is 0.53 mA when the irradiance  $H$  is 12.45 mW/cm<sup>2</sup>.
2. The maximum detection distance of this specification is guaranteed by  $T_{WH}$  and  $T_{WL}$  being within the limits when constant 16 pulses are transmitted with the output of the transmitter unit corresponded to the maximum detection distance in the system above.  
(The maximum detection distance is measured in the darkness without disturbing noises.)

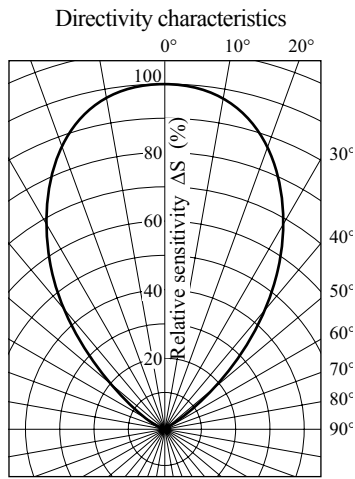
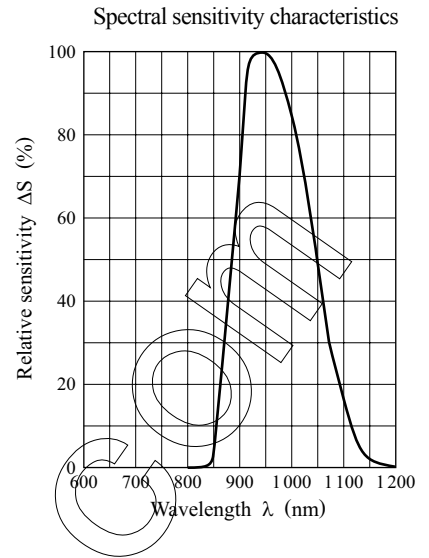
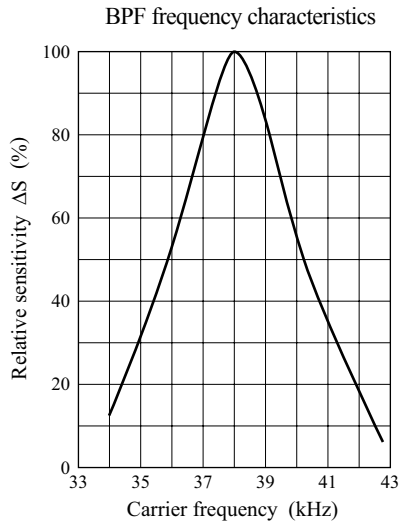
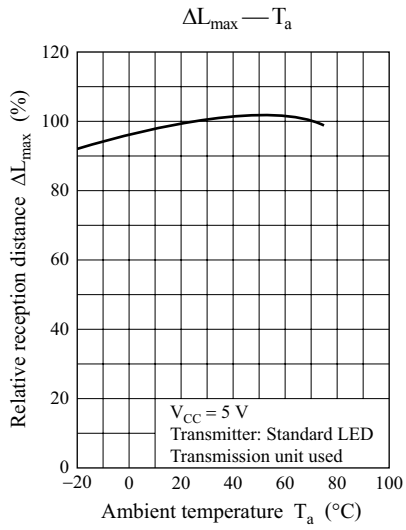

www.yc-dz.com

## Request for your special attention and precautions in using the technical information and semiconductors described in this material

- (1) An export permit needs to be obtained from the competent authorities of the Japanese Government if any of the products or technical information described in this material and controlled under the "Foreign Exchange and Foreign Trade Law" is to be exported or taken out of Japan.
- (2) The technical information described in this material is limited to showing representative characteristics and applied circuits examples of the products. It neither warrants non-infringement of intellectual property right or any other rights owned by our company or a third party, nor grants any license.
- (3) We are not liable for the infringement of rights owned by a third party arising out of the use of the technical information as described in this material.
- (4) The products described in this material are intended to be used for standard applications or general electronic equipment (such as office equipment, communications equipment, measuring instruments and household appliances).  
Consult our sales staff in advance for information on the following applications:
  - Special applications (such as for airplanes, aerospace, automobiles, traffic control equipment, combustion equipment, life support systems and safety devices) in which exceptional quality and reliability are required, or if the failure or malfunction of the products may directly jeopardize life or harm the human body.
  - Any applications other than the standard applications intended.
- (5) The products and product specifications described in this material are subject to change without notice for modification and/or improvement. At the final stage of your design, purchasing, or use of the products, therefore, ask for the most up-to-date Product Standards in advance to make sure that the latest specifications satisfy your requirements.
- (6) When designing your equipment, comply with the guaranteed values, in particular those of maximum rating, the range of operating power supply voltage, and heat radiation characteristics. Otherwise, we will not be liable for any defect which may arise later in your equipment.  
Even when the products are used within the guaranteed values, take into the consideration of incidence of break down and failure mode, possible to occur to semiconductor products. Measures on the systems such as redundant design, arresting the spread of fire or preventing glitch are recommended in order to prevent physical injury, fire, social damages, for example, by using the products.
- (7) When using products for which damp-proof packing is required, observe the conditions (including shelf life and amount of time let standing of unsealed items) agreed upon when specification sheets are individually exchanged.
- (8) This material may be not reprinted or reproduced whether wholly or partially, without the prior written permission of Matsushita Electric Industrial Co., Ltd.