

◆ Features

- Outside the Shielding, High protection ability against EMI
- Wide voltage operating: 2.7V~5.5V
- Wide half angle & long reception distance
- Automatic supply voltage adaptation
- Enhanced immunity against all kind of disturbance light
- TTL and CMOS compatibility
- Automatic sensitivity adaptation (AGC) and automatic Strong signal adaptation (ATC)
- Automatic bias control for sunlight

◆ Applications

- AV equipment (TV, DVD Player, VCR, Audio, CD player, STB, etc)
- Home appliances (Camera, Computer Air Conditioner, Fan, light, etc)
- Infrared remote control Toys.

External Dimensions

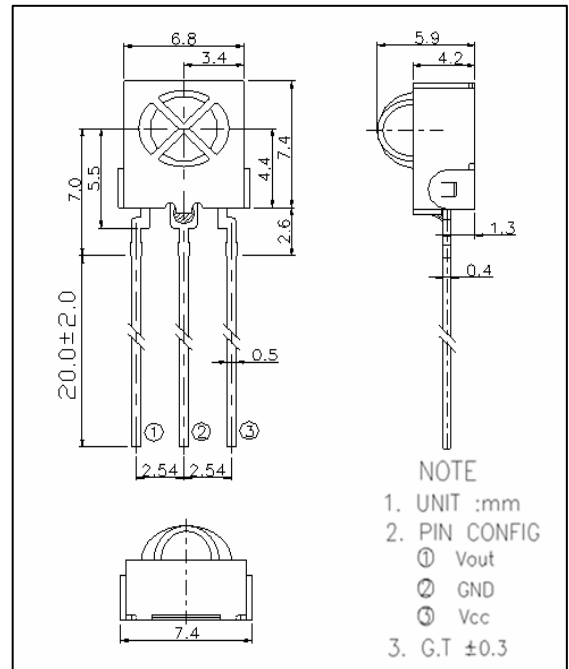

◆ Center frequency

◇ 37.9KHz

◆ Electro-optical Characteristics

(Ta=25°C)

Parameter	Symbol	Conditions	Min.	Typ.	Max.	Unit
Supply Voltage	Vcc		2.7		5.5	V
Supply Current	Icc	No Input Signal		0.9	1.5	mA
Reception Distance	d	200±50Lux Vcc=3V	12	21		m
Half Angle (Horizontal)	Δθh			±45		deg
Half Angle (Vertical)	Δθv			±45		deg
B.P.F. Center Frequency	Fo			37.9		KHz
Peak Wavelength	λp			940		nm
Signal Output	So		--- Active Low ---			
High Level Output Voltage	Voh		VDD-0.3		VDD	V
Low Level Output Voltage	Vol				0.4	V
High Level Pulse Width	Twh	Burst Wave = 600μs	400	--	800	μs
Low Level Pulse Width	Twl	Burst Wave = 600μs	400	--	800	μs

◆ Absolute Maximum

(Ta=25°C)

Parameter	Symbol	Ratings	Unit
Supply Voltage	Vcc	6.0	V
Operating Temperature	Topr	-25~ +80	°C
Storage Temperature	Tstg	-40 ~ +85	°C
Soldering Temperature *1	Tsol	260	°C

*1 At the position of 2mm from the bottom of the package within 5 seconds.



Block Diagram

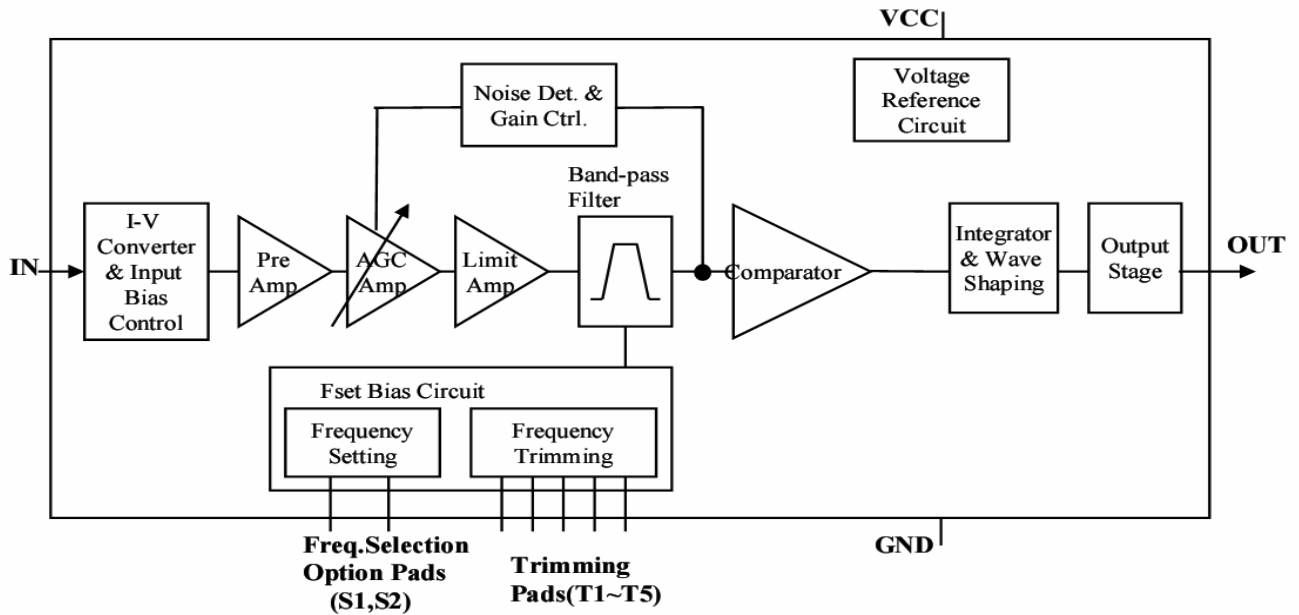

Reliability Test Items

Test Items	Test Conditions	Ratings
High Temperature Storage	Ta=+85°C, Vcc=3.0V	t=240hr.
Low Temperature Storage	Ta=-40°C, Vcc=3.0V	t=240hr.
High Temperature High Humid Storage	Ta=40°C, 90%RH, Vcc=3.0V	t=240hr.
Temperature Cycling	-40°C (30min) ~ +85°C (30min)	20cycles test

Relative Reception Distance vs Transmitter Carrier Frequency

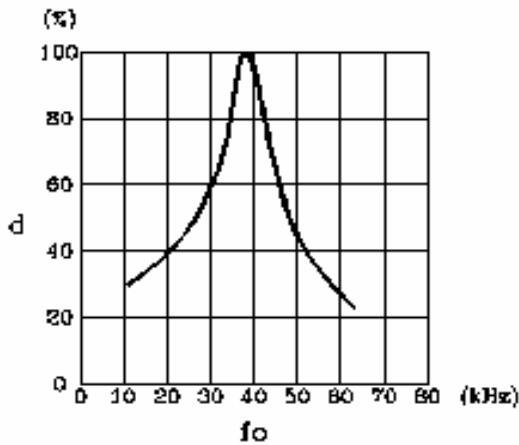

Sensitivity Diagram

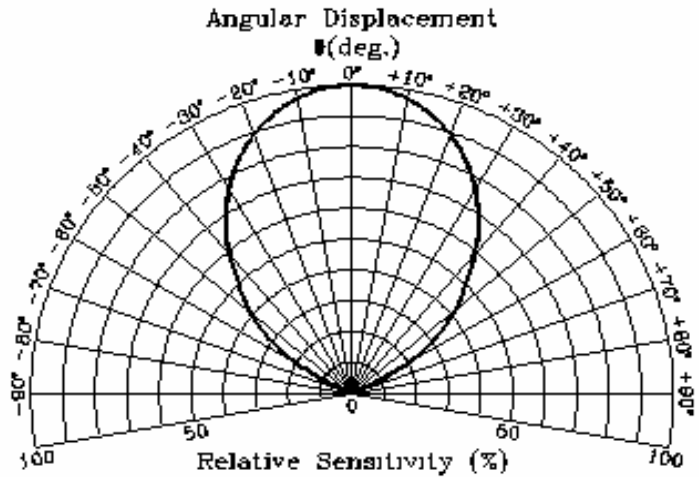

Standard Inspection

Among electrical characteristics, total quantity will be inspected as below:

- Distance between emitter and detector
- Current consumption
- H level output voltage
- L level output voltage

◆ Testing Method

Distance between emitter and detector specifies maximum distance that output waveform satisfies the standard (FIG-1) under the conditions below against the standard transmitter.

- a. Measuring place
Indoor without extreme reflection of light.
- b. Ambient light source
Detecting surface illumination is 200 ± 50 Lux under ordinary white fluorescence lamp of no high frequency lightning.
- c. Standard transmitter
Transmitter wave indicated in FIG-2 of standard transmitter is arranged to satisfy $V_o \geq 50$ mVp-p under the measuring circuit specified in FIG-3

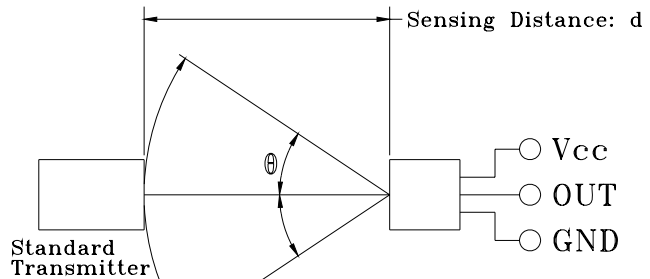
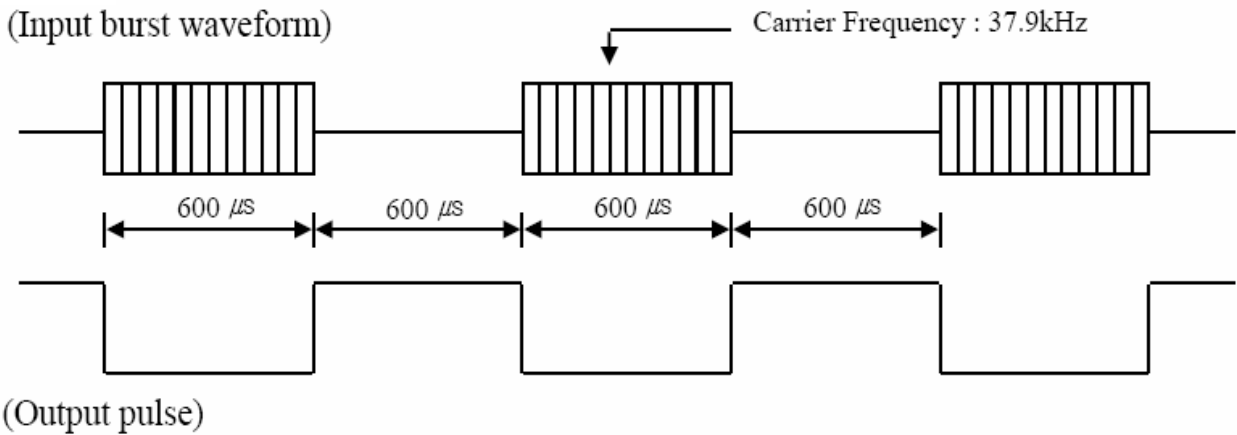

FIG-1

Fig-2



◆ Application circuit

Fig-3

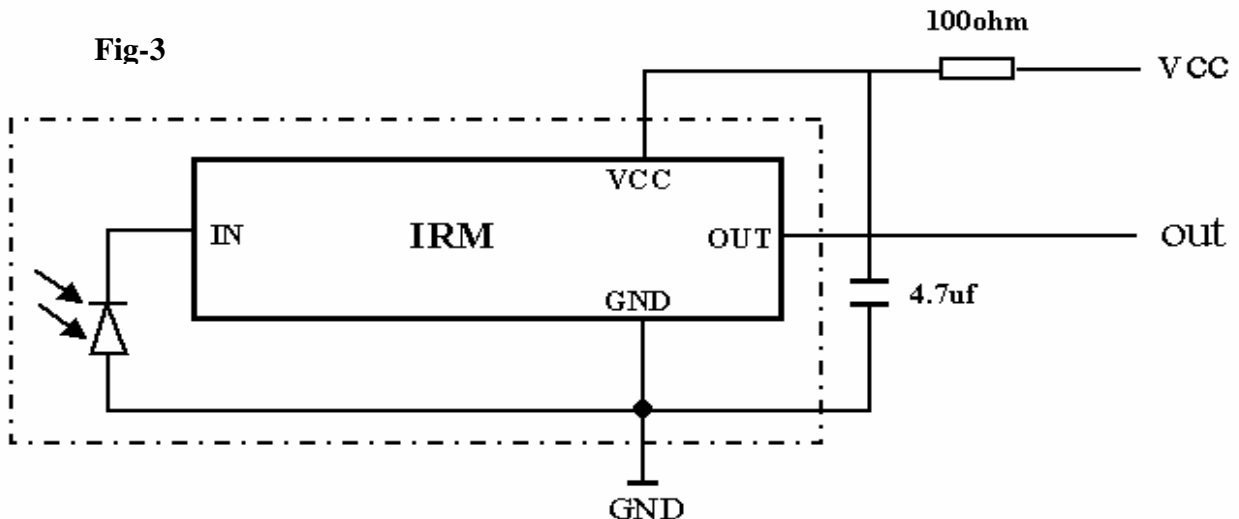

◆ Application Guide

1. In the detection or demodulation (wave shape) of incoming signal, IRM module need the minimum burst length of modulated signals.
2. The incoming photo signal is modulated with proper carrier signal (e.g.37.9KHz) and if the '1' data bit is modulated with carrier signal, the period of data bit '1' is important.
3. Because the carrier signals is in this period, in the integrator& wave shape block of IRM module the integration need minimum period to the reach of appropriately level.
4. Hence the minimum burst length is important characteristic and specification of remote control systems
5. The minimum burst length of IRM is about 10 cycles of carrier. ($\sim 10 \cdot T_{fc}$)
You can easily understand as see the figure 4.

Figure 4.

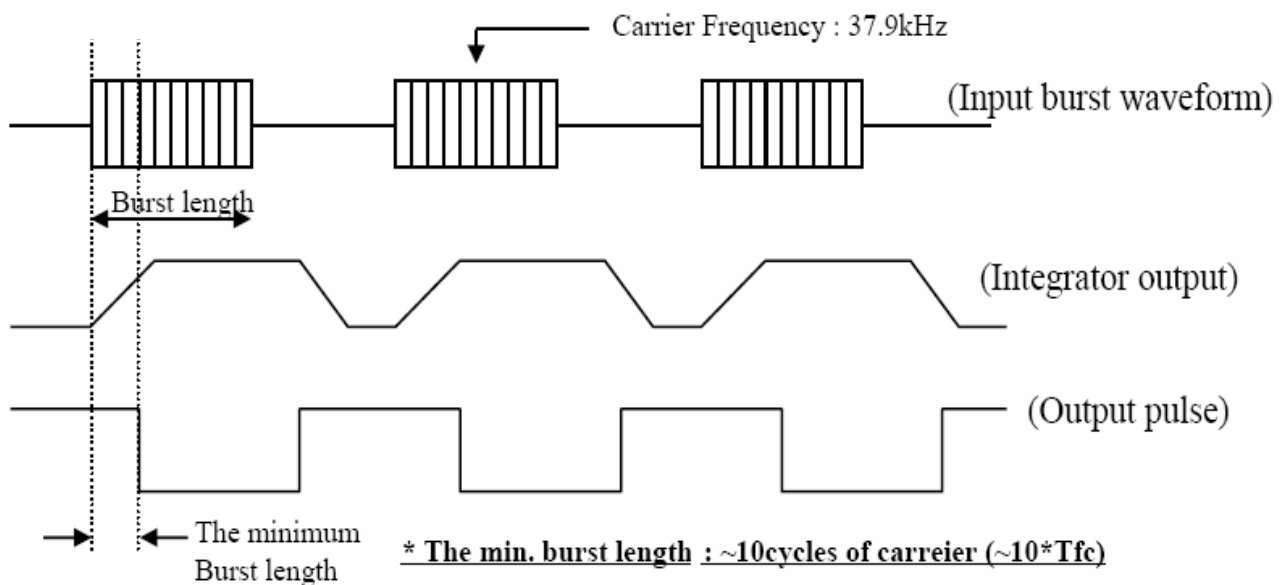

◆ Precautions for Use

- a. Store and use where there is no force causing transformation or change in quality.
- b. Store and use where there is no corrosive gas or sea (salt) breeze.
- c. Store and use where there is no extreme humidity.
- d. Solder the lead pin within the condition of ratings. After soldering, don't add exterior force.
- e. Do not wash this device. Wipe the stains of diode side with a soft cloth. You can use the solvent, ethyl alcohol, or methyl alcohol only.
- f. To prevent static electricity damage to the pre-amp, make sure that the human body, the soldering iron are connected to ground before using.

◆ Package Dimensions

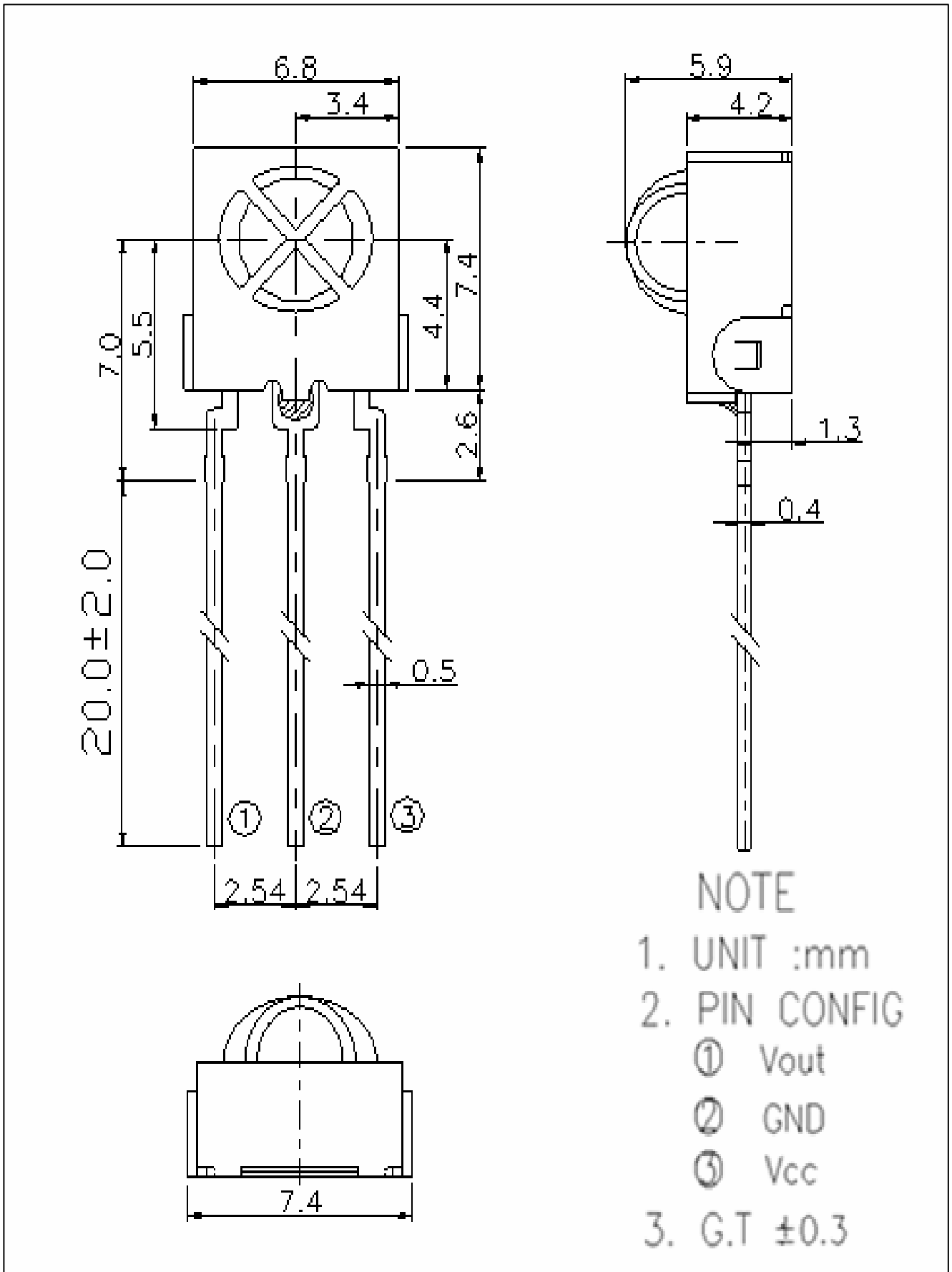

◆ Packaging Box Dimensions

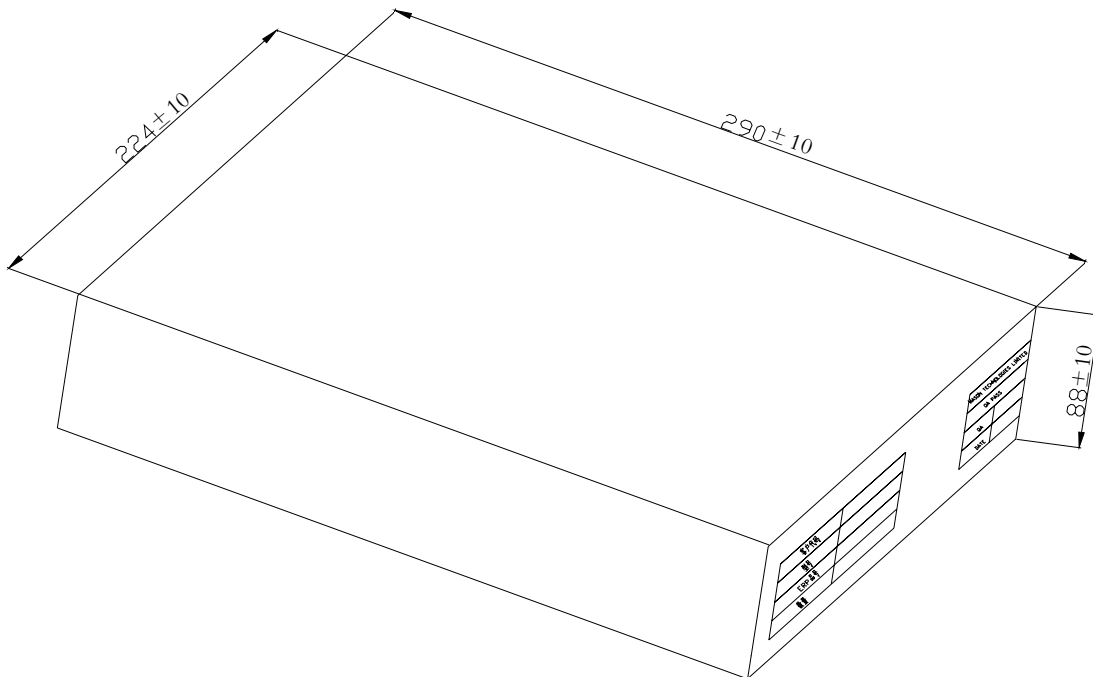

◆ Packaging Bag Dimensions

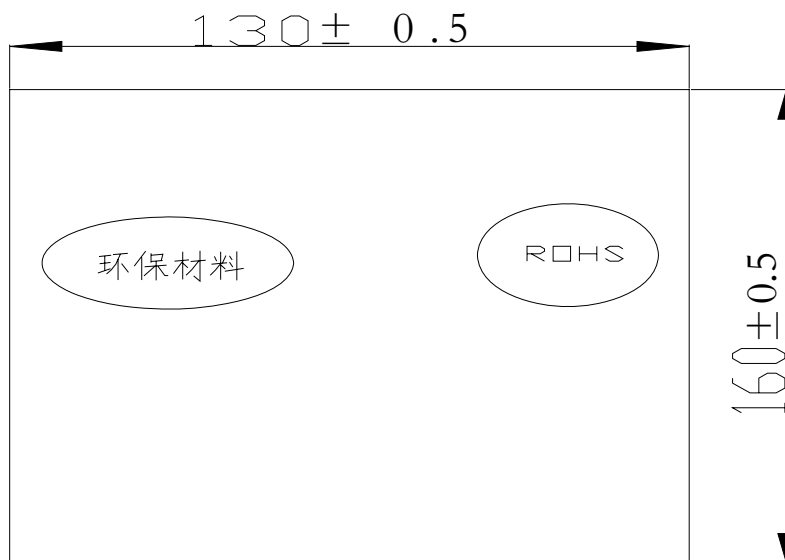

Notes:

- 1.200pcs per bag, 3Kpcs per box
- 2.All dimensions are in millimeters
- 3.Specifications are subject to chang without notice