

TGS 4161 - for the detection of Carbon Dioxide

Features:

- * High selectivity to CO₂
- * Compact size
- * Low dependency on humidity
- * Long life and low cost
- * Low power consumption

Applications:

- * Indoor air quality control

TGS4161 is a new solid electrolyte CO₂ sensor which offers miniaturization and low power consumption. A range of 350~5,000ppm of carbon dioxide can be detected by TGS4161, making it ideal for indoor air control applications.

The CO₂ sensitive element consists of a solid electrolyte formed between two electrodes, together with a printed heater (RuO₂) substrate. By monitoring the change in electromotive force (EMF) generated between the two electrodes, it is possible to measure CO₂ gas concentration.

The top of the sensor cap contains adsorbent (zeolite) for the purpose of reducing the influence of interference gases.

TGS4161 exhibits a linear relationship between ΔEMF and CO₂ gas concentration on a logarithmic scale. The sensor displays good long term stability and shows excellent durability against the effects of high humidity.



The figure below represents typical sensitivity characteristics of TGS4161. The Y-axis is indicated as ΔEMF which is defined as follows:

$$\Delta EMF = EMF1 - EMF2$$

where

EMF1=EMF in 350 ppm CO₂

EMF2=EMF in listed gas concentration

The figure below shows typical humidity dependency of TGS4161. Again, the Y-axis is indicated as ΔEMF which is defined as follows:

$$\Delta EMF = EMF1 - EMF2$$

where

EMF1=EMF in 350 ppm CO₂

EMF2=EMF in 1000ppm CO₂

Sensitivity Characteristics:

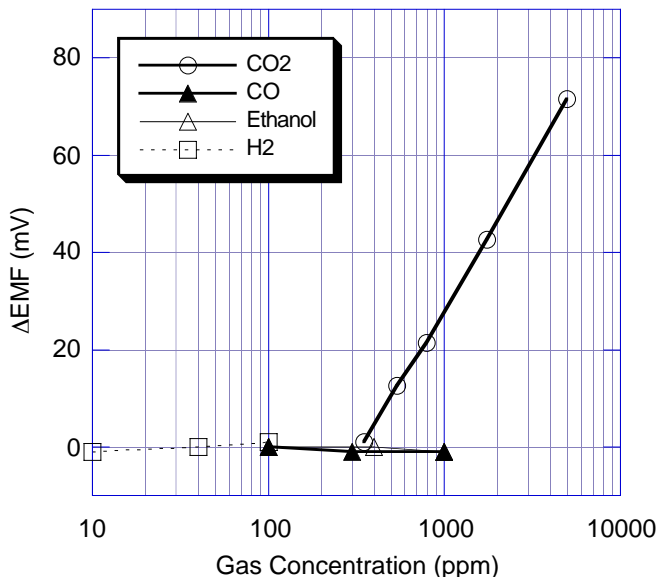

Humidity Dependency:

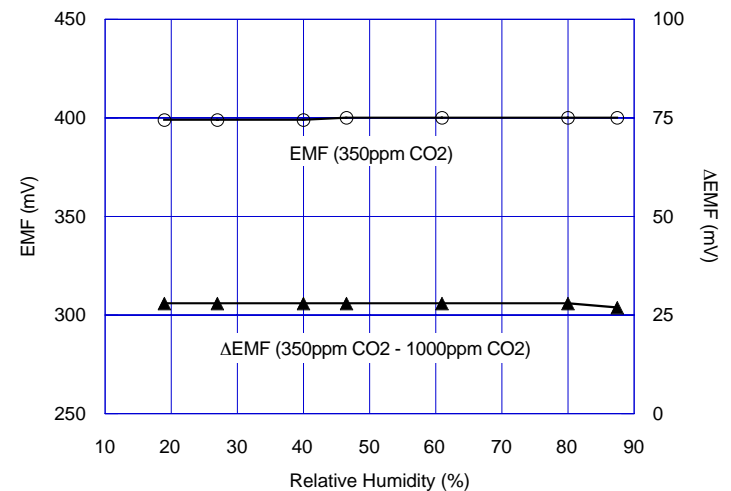

IMPORTANT NOTE: OPERATING CONDITIONS IN WHICH FIGARO SENSORS ARE USED WILL VARY WITH EACH CUSTOMER'S SPECIFIC APPLICATIONS. FIGARO STRONGLY RECOMMENDS CONSULTING OUR TECHNICAL STAFF BEFORE DEPLOYING FIGARO SENSORS IN YOUR APPLICATION AND, IN PARTICULAR, WHEN CUSTOMER'S TARGET GASES ARE NOT LISTED HEREIN. FIGARO CANNOT ASSUME ANY RESPONSIBILITY FOR ANY USE OF ITS SENSORS IN A PRODUCT OR APPLICATION FOR WHICH SENSOR HAS NOT BEEN SPECIFICALLY TESTED BY FIGARO.

Basic Measuring Circuit:

The TGS4161 sensor requires heater voltage (V_H) input. The heater voltage is applied to the integrated heater in order to maintain the sensing element at a specific temperature which is optimal for sensing. Electromotive force (EMF) of the sensor should be measured using a high impedance ($>100\text{G}\Omega$) operational amplifier with bias current $< 1\text{pA}$ (e.g. Texas Instruments' model #TLC271). Since the solid electrolyte type sensor

functions as a kind of battery, the EMF value itself would drift using this basic measuring circuit. However, the change of EMF value (ΔEMF) shows a stable relationship with the change of CO_2 concentration. Therefore, in order to obtain an accurate measurement of CO_2 , a special microprocessor for signal processing should be used with TGS4161. Figaro can provide a special evaluation sensor module (AM-4) for TGS4161.

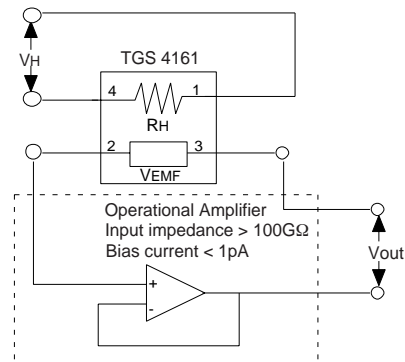

Specifications:

Model number		TGS 4161	
Sensing element type		Solid electrolyte	
Target gases		Carbon dioxide	
Typical detection range		350 ~ 5000 ppm	
Electrical characteristics	Heater resistance	R_H	$70 \pm 7\Omega$ at room temp.
	Heater current	I_H	approx. 50mA
	Heater power consumption	P_H	approx. 250mW
	Electromotive force	EMF	220~490mV in 350ppm CO_2
	Sensitivity	ΔEMF	44~72mV
	Heater voltage	V_H	$5.0 \pm 0.2\text{V}$ (DC)
Sensor characteristics	Response time	approx. 1.5 min. (to 90% of final value)	
	Measurement accuracy	approx. $\pm 20\%$ at 1,000ppm CO_2	
Operating conditions		$-10\sim 50^\circ\text{C}$, 5~95%RH	
Storage conditions		$-20\sim 60^\circ\text{C}$, 5~90%RH (store in moisture proof bag with silica gel)	
Standard test conditions	Test gas condition	CO_2 in air at $20 \pm 2^\circ\text{C}$, 65 \pm 5%RH	
	Circuit condition	$V_H = 5.0 \pm 0.05\text{V}$ DC	
	Conditioning period before test	2 days	

Structure and Dimensions:

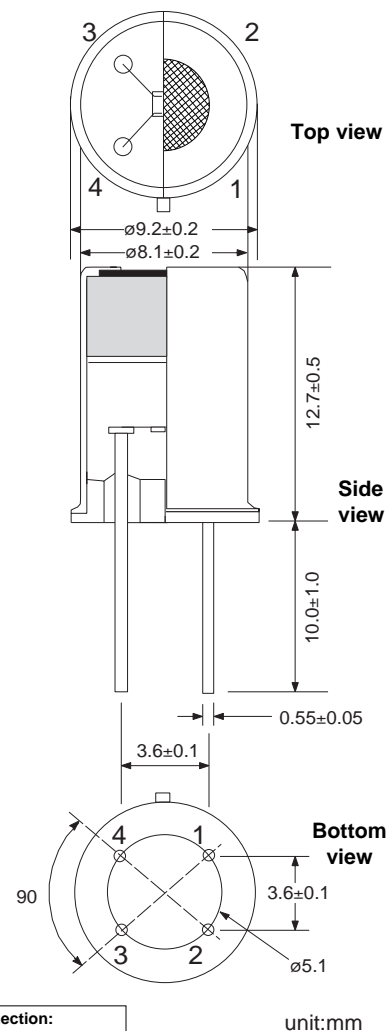

Sensing Element Structure:

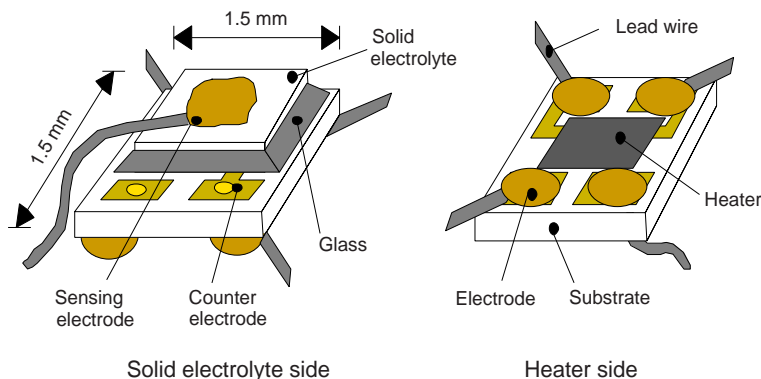

Pin Connection:

1. Heater (+)
2. Counter electrode (+)
3. Sensing electrode (-)
4. Heater (-)

unit:mm

For information on warranty, please refer to Standard Terms and Conditions of Sale of Figaro USA Inc.

REV: 04/03

FIGARO ENGINEERING INC.
1-5-11 Senba-nishi
Mino, Osaka 562-8505 JAPAN
Phone: (81)-72-728-2561
Fax: (81)-72-728-0467
email: figaro@figaro.co.jp

FIGARO USA, INC.
3703 West Lake Ave. Suite 203
Glenview, Illinois 60025 USA
Phone: (1)-847-832-1701
Fax: (1)-847-832-1705
email: figarousa@figarosensor.com