

Spec. No.	413-212-089
Doc. version :	1
Total pages :	19
Date :	2002/10/21

## Product Specification

### 2.5" COLOR TFT-LCD MODULE

MODEL NAME: A025CN01 Ver.3 (UP025D11-3)

< > Preliminary Specification

< > Final Specification

Official UK Representative

**DISPLAZE**  
LIMITED

Unit A Merlin Centre, Gatehouse Close,  
Aylesbury, HP19 8DP, ENGLAND

Tel.: +44 (0)1296-469770 Fax.: +44 (0)1296-469779  
sales@displaze.com www.displaze.com

Please verify this is the latest information. E&OE

Note: The content of this specification is subject to change.

© 2001 AU Optronics  
All Rights Reserved,  
Do Not Copy.



**Contents:**

**A. Physical specifications. . . . . P3**

**B. Electrical specifications. . . . . P4**

1. Pin assignment. . . . . P4

    a. TFT-LCD panel driving section. . . . . P4

    b. Backlight driving section. . . . . P5

2. Absolute maximum ratings. . . . . P5

3. Electrical characteristics. . . . . P6

    a. Typical operating conditions. . . . . P6

    b. Current consumption. . . . . P6

    c. Backlight driving conditions. . . . . P6

4. AC Timing. . . . . P7

    a. Timing conditions. . . . . P7

    b. Timing diagram. . . . . P7

**C. Optical specifications. . . . . P8**

**D. Reliability test items. . . . . P10**

**E. Packing form . . . . . P11**

**Appendix:**

Fig.1 Outline dimension of TFT-LCD module.....	<b>P12</b>
Fig.2 Sampling clock timing.....	<b>P13</b>
Fig.3 Horizontal display timing range.....	<b>P14</b>
Fig.4-(a) Horizontal timing.....	<b>P15</b>
Fig.4-(b) Detail horizontal timing.....	<b>P16</b>
Fig.5 Vertical shift clock timing.....	<b>P17</b>
Fig.6-(a) Vertical timing (From up to down).....	<b>P18</b>
Fig.6-(b) Vertical timing (From down to up).....	<b>P19</b>

www.yc-dz.com

**A. Physical specifications**

NO.	Item	Specification	Remark
1	Display resolution(dot)	480(W) x234(H)	
2	Active area(mm)	49.2(W) x88.142(H)	
3	Screen size(inch)	2.45(Diagonal)	
4	Dot pitch(mm)	0.1025(W) x0.163(H)	
5	Color configuration	R. G. B. delta	
6	Overall dimension(mm)	58.8(W) x49.9(H) x5.7(D)	Note 1
7	Weight(g)	25 ±5	

Note 1: Refer to Fig. 1

www.yc-dz.com

## B. Electrical specifications

### 1.Pin assignment

#### a. TFT-LCD panel driving section

Pin no	Symbol	I/O	Description	Remark
1	STHL	I/O	Start pulse for horizontal scan line	Note 1
2	OEH	I	Output enable input for data driver	
3	Q1H	I	Analog signal rotate input	
4	CPH1	I	Sampling and shifting clock pulse for data driver	
5	CPH2	I	Sampling and shifting clock pulse for data driver	
6	CPH3	I	Sampling and shifting clock pulse for data driver	
7	GND	-	Ground	
8	VB	I	Alternated video signal input(Blue)	
9	VG	I	Alternated video signal input(Green)	
10	VR	I	Alternated video signal input(Red)	
11	NC	-	This pin should be electrical opened during operation	
12	L/R	I	Left/Right scan control input	Note 1,2
13	STHR	I/O	Start pulse for horizontal scan line	Note 1
14	AV <sub>DD</sub>	I	Supply voltage for analog circuit	
15	VCOM	I	Common electrode driving signal	
16	V <sub>GH</sub>	I	Positive power for scan driver	
17	V <sub>CC</sub>	I	Logic power for scan & data driver	
18	STVL	I/O	Vertical start pulse	Note 1
19	OEV	I	Output enable input for scan driver	
20	CKV	I	Shift clock input for scan driver	
21	U/D	I	UP/DOWN scan control input	Note 1,2
22	STVR	I/O	Vertical start pulse	Note 1
23	NC	-	This pin should be electrical opened during operation	
24	V <sub>GL</sub>	I	Negative power for scan driver	

Note 1 : Selection of scanning mode

Setting of scan control input		IN/OUT state For start pulse				Scanning direction
U/D	L/R	STVR	STVL	STHR	STHL	
GND	V <sub>CC</sub>	OUT	IN	OUT	IN	From up to down, and from left to right.
V <sub>CC</sub>	GND	IN	OUT	IN	OUT	From down to up, and from right to left.
GND	GND	OUT	IN	IN	OUT	From up to down, and from right to left.
V <sub>CC</sub>	V <sub>CC</sub>	IN	OUT	OUT	IN	From down to up, and from left to right.

IN: Input; OUT: Output.

Note 2 : Definition of scanning direction.

Refer to figure as below:

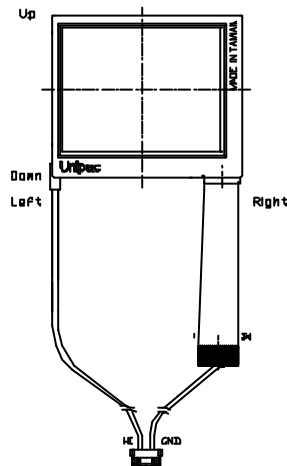

b. Backlight driving section (Refer to Fig.1)

No.	Symbol	I/O	Description	Remark
1	HI	I	Power supply for backlight unit ( High voltage)	
2	GND		Ground	

## 2. Absolute maximum ratings

Item	Symbol	Condition	Min.	Max.	Unit	Remark
Power voltage	V <sub>CC</sub>	GND=0	-0.3	7	V	
	AV <sub>DD</sub>	AV <sub>SS</sub> =0	-0.3	7	V	
	V <sub>GH</sub>	GND=0	-0.3	18	V	
	V <sub>GL</sub>		-18	0.3	V	
	V <sub>GH</sub> - V <sub>GL</sub>		-	36	V	
Input signal voltage	V <sub>i</sub>		-0.3	AV <sub>DD</sub> +0.3	V	Note 1
	V <sub>I</sub>		-0.3	V <sub>CC</sub> +0.3	V	Note 2
	V <sub>COM</sub>		-2.9	5.2	V	
Operating temperature	Topa		0	60		Ambient temperature
Storage temperature	Tstg		-25	80		Ambient temperature

Note 1: VR, VG, VB

Note 2: STHL, STHR, Q1H,OEH,L/R,CPH1~CPH3, STVR, STVL,OEV,CKV,U/D.

### 3. Electrical characteristics

#### a. Typical operating conditions (GND=AVss=0V)

Item	Symbol	Min.	Typ.	Max.	Unit	Remark
Power supply	V <sub>CC</sub>	3	5	5.2	V	
	AV <sub>DD</sub>	4.8	5	5.2	V	
	V <sub>GH</sub>	14.3	15	15.7	V	
	V <sub>GLAC</sub>	3.5	5	7.5	V <sub>p-p</sub>	AC component of V <sub>GL</sub> . Note 1
	V <sub>GL-H</sub>	-10	-9.5	-9	V	High level of V <sub>GL</sub> .
Video signal Amplitude (VR,VG,VB)	V <sub>iA</sub>	AV <sub>SS</sub> +0.4	-	AV <sub>DD</sub> -0.4	V	Note 2
	V <sub>iAC</sub>	-	3		V	AC component
	V <sub>iDC</sub>	-	AV <sub>DD</sub> /2	-	V	DC component
VCOM	V <sub>CAC</sub>	3.5	5	7.5	V <sub>p-p</sub>	AC component,Note 3
	V <sub>CDC</sub>	-	1.1	-	V	DC component
Input Signal voltage	H Level	V <sub>IH</sub>	0.8 V <sub>CC</sub>	V <sub>CC</sub>	V	Note 4
	L Level	V <sub>IL</sub>	0	0.2 V <sub>CC</sub>	V	

Note 1: The same phase and amplitude with common electrode driving signal(VCOM).

Note 2: Refer to Fig.4-(a)

Note 3: The brightness of LCD panel could be adjusted by the adjustment of the AC component of VCOM.

Note 4: STHL,STHR,Q1H,OEH,L/R,CPH1~CPH3,STVR,STVL,OEV,CKV,U/D.

Note 5: Be sure to apply GND, V<sub>CC</sub>, V<sub>GL</sub> to the LCD first, and then apply V<sub>GH</sub>.

#### b. Current consumption (GND=AVss=0V)

Parameter	Symbol	Condition	Min.	Typ.	Max.	Unit	Remark
Current for driver	I <sub>GH</sub>	V <sub>GH</sub> =15V	-	50	100	μA	
	I <sub>GL</sub>	V <sub>GL-H</sub> =-10V	-	-0.3	-0.6	mA	
	I <sub>CC</sub>	V <sub>CC</sub> =5V	-	1.5	4	mA	
	I <sub>DD</sub>	AV <sub>DD</sub> =5V	-	5	10	mA	

#### c. Backlight driving conditions

Parameter	Symbol	Min.	Typ.	Max.	Unit	Remark
Lamp voltage	V <sub>L</sub>	210	230	250	V <sub>rms</sub>	
Lamp current	I <sub>L</sub>	2.4	2.7	3.0	mArms	
Frequency	F <sub>L</sub>	55	60	65	KHz	Note 3
Lamp starting Voltage	V <sub>s</sub>	-	-	460	V <sub>rms</sub>	Note 1,4
		-	-	690	V <sub>rms</sub>	Note 2,4

Note 1: Ta = 25

Note 2: Ta = 0



Note 3: The lamp frequency should be selected as different as possible from display horizontal synchronous signal to avoid interference.

Note 4: For starting the backlight unit, the output voltage of DC/AC's transformer should be larger than the maximum lamp starting voltage.

#### 4. AC Timing

##### a. Timing conditions

Parameter	Symbol	Min.	Typ.	Max.	Unit.	Remark
Rising time	$t_r$	-	-	10	ns	Note 1
Falling time	$t_f$	-	-	10	ns	Note 1
High and low level pulse width	$t_{CPH}$	299	308	319	ns	CPH1~CPH3
CPH pulse duty	$t_{CWH}$	40	50	60	%	CPH1~CPH3
CPH pulse delay	$t_{C12}$ $t_{C23}$ $t_{C31}$	70	$t_{CPH}/3$	$t_{CPH}/2$	ns	CPH1~CPH3
STH setup time	$t_{SUH}$	35	-	-	ns	STHR,STHL
STH hold time	$t_{HDH}$	35	-	-	ns	STHR,STHL
STH pulse width	$t_{STH}$	-	1	-	$t_{CPH}$	STHR,STHL
STH period	$t_H$	61.5	63.5	65.5	$\mu s$	STHR,STHL
OEH pulse width	$t_{OEH}$	-	3	-	$t_{CPH}$	OEH
Sample and hold disable time	$t_{DIS1}$	-	28	-	$t_{CPH}$	
OEV pulse width	$t_{OEV}$	-	12	-	$t_{CPH}$	OEV
CKV pulse width	$t_{CKV}$	16	28	40	$t_{CPH}$	CKV
Clean enable time	$t_{DIS2}$	-	10	-	$t_{CPH}$	
Horizontal display start	$t_{SH}$	-	0	-	$t_{CPH}/3$	
Horizontal display timing range	$t_{DH}$	-	480	-	$t_{CPH}/3$	
STV setup time	$t_{SUV}$	400	-	-	ns	STVL,STVR
STV hold time	$t_{HDV}$	400	-	-	ns	STVL,STVR
STV pulse width	$t_{STV}$	-	-	1	$t_H$	STVL,STVR
Horizontal lines per field	$t_v$	256	262	268	$t_H$	Note 2
Vertical display start	$t_{SV}$	-	3	-	$t_H$	
Vertical display timing range	$t_{DV}$	-	234	-	$t_H$	
VCOM rising time	$t_{rCOM}$	2	-	3	$\mu s$	
VCOM falling time	$t_{fCOM}$	2	-	3	$\mu s$	
VCOM delay time	$t_{DCOM}$	-	-	3	$\mu s$	
RGB delay time	$t_{DRGB}$	-	-	1	$\mu s$	

Note 1: For all of the logic signals.

Note 2: Please don't use odd horizontal lines to drive LCD panel for both odd and even fields simultaneously.

##### b. Timing diagram

Please refer to the attached drawings, from Fig.2 to Fig.6.

**C. Optical specification (Note 1, Note 2, Note 3)**

Item	Symbol	Condition	Min.	Typ.	Max.	Unit	Remark
Response time	Rise	$=0^\circ$	-	20	30	ms	Note 4, 6
	Fall		-	30	40	ms	
Contrast ratio	CR	At optimized viewing angle	100	150	-		Note 5, 6
Viewing angle	Top	CR 10	10	-	-	deg.	Note 6, 7
	Bottom		30	-	-		
	Left		45	-	-		
	Right		45	-	-		
Brightness	$Y_L$	$=0^\circ$	200	250	-	nit	Note 8
White chromaticity	X	$=0^\circ$	0.25	0.3	0.35		Note 8
	y		0.3	0.35	0.4		

Note 1. Ambient temperature  $=25^\circ$  and lamp current  $I_L = 2.7\text{mA}$  rms.

Note 2. To be measured in the dark room.

Note 3. To be measured at the center area of panel with a viewing cone of  $1^\circ$  by Topcon luminance meter BM-7, after 10 minutes operation.

Note 4. Definition of response time:

The output signals of photodetector are measured when the input signals are changed from "black" to "white" (falling time) and from "white" to "black" (rising time), respectively.

The response time is defined as the time interval between the 10% and 90% of amplitudes. Refer to figure as below.

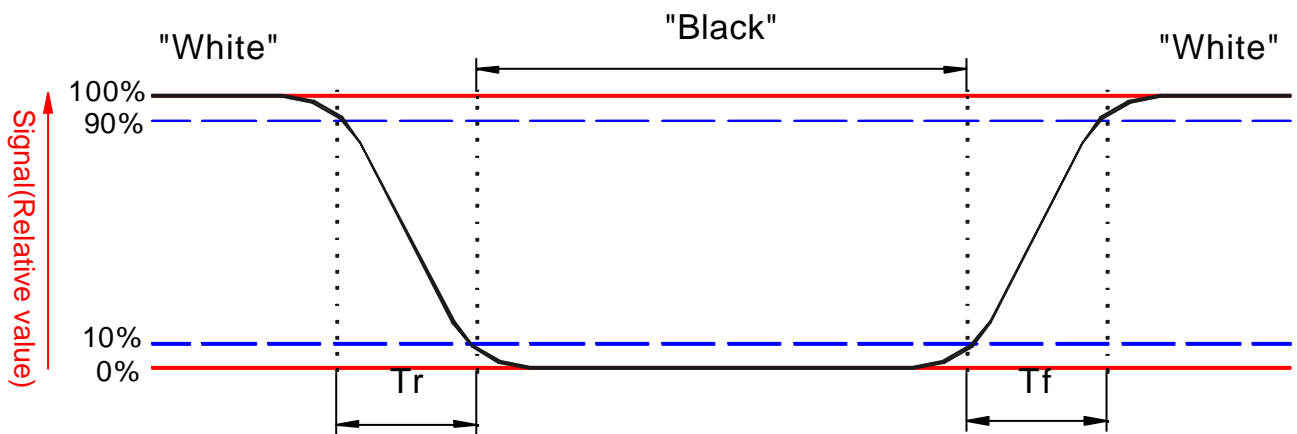

Note 5. Definition of contrast ratio:

Contrast ratio is calculated with the following formula.

$$\text{Contrast ratio (CR)} = \frac{\text{Photodetector output when LCD is at "White" state}}{\text{Photodetector output when LCD is at "Black" state}}$$

Note 6. White  $V_i = V_{i50} + 1.5V$

Black  $V_i = V_{i50} \pm 2.0V$

“±” means that the analog input signal swings in phase with COM signal.

“+” means that the analog input signal swings out of phase with COM signal.

$V_{i50}$  : The analog input voltage when transmission is 50%

The 100% transmission is defined as the transmission of LCD panel when all the input terminals of module are electrically opened.

Note 7. Definition of viewing angle:

Refer to figure as below.

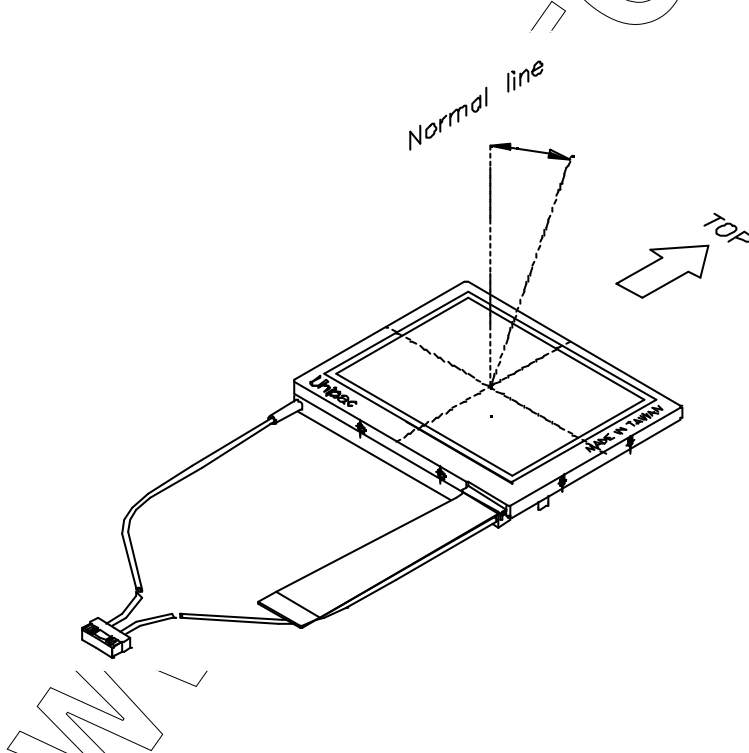

Note 8. Measured at the center area of the panel when all the input terminals of LCD panel are electrically opened.

**D. Reliability test items:**

No.	Test items	Conditions	Remark
1	High temperature storage	Ta= 80 240H	
2	Low temperature storage	Ta= -25 240H	
3	High temperature operation	Ta= 60 240H	
4	Low temperature operation	Ta= 0 240H	
5	High temperature and high humidity	Ta= 60 . 95% RH 240H	Operation
6	Heat shock	-25 ~80 /50 cycle 2H/cycle	Non-operation
7	Electrostatic discharge	±200V,200pF(0 ), once for each terminal	Non-operation
8	Vibration	Frequency range : 10~55Hz Stoke : 1.5mm Sweep : 10~55Hz~10Hz 2 hours for each direction of X,Y,Z (6 hours for total)	JIS C7021, A-10 condition A
9	Mechanical shock	100G . 6ms, ±X, ±Y, ±Z 3 times for each direction	JIS C7021, A-7 condition C
10	Vibration (with carton)	Random vibration: 0.015G <sup>2</sup> /Hz from 5~200Hz -6dB/Octave from 200~500Hz	IEC 68-34
11	Drop (with carton)	Height: 80cm 1 corner, 3 edges, 6 surfaces	

Note: Ta: Ambient temperature.

### E.Packing form

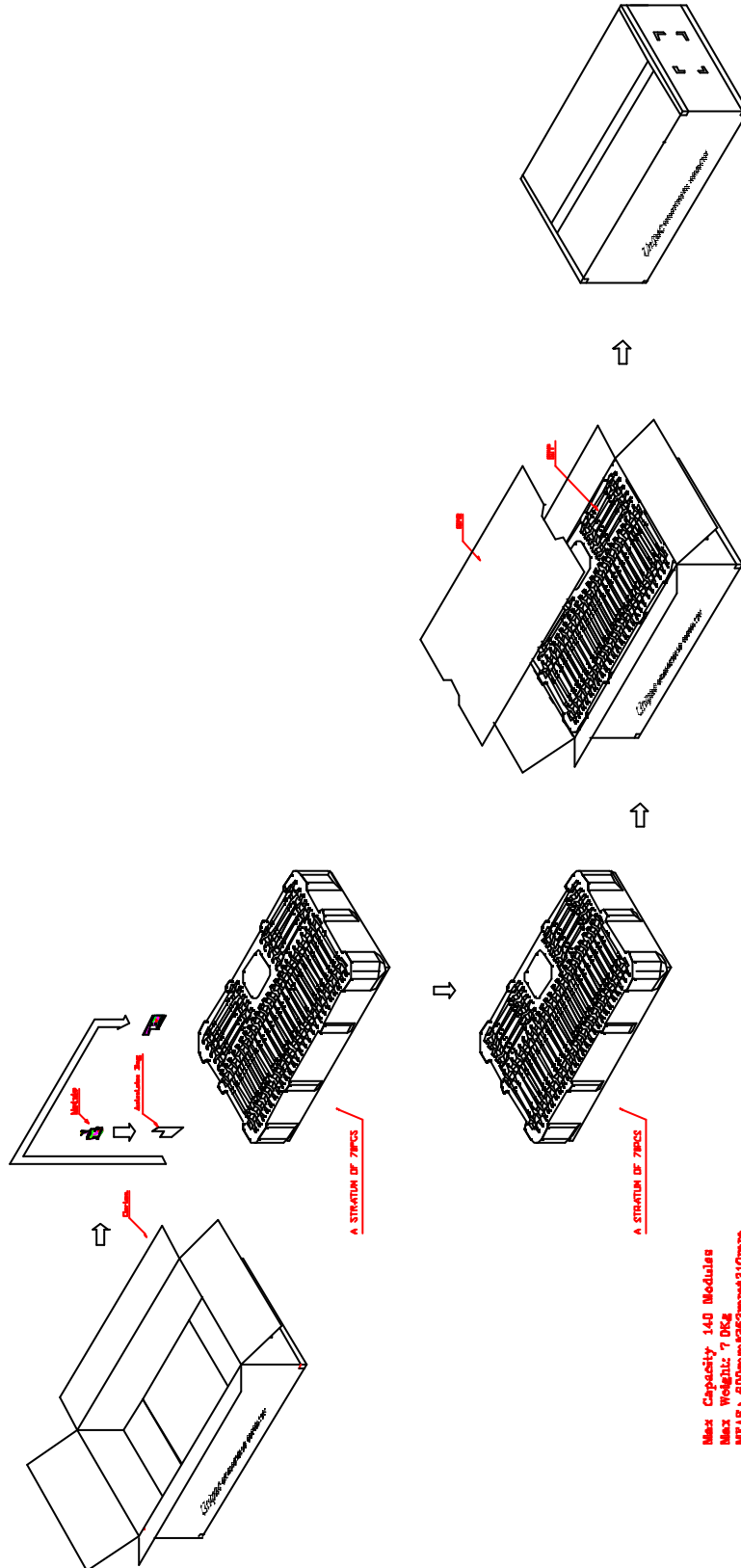

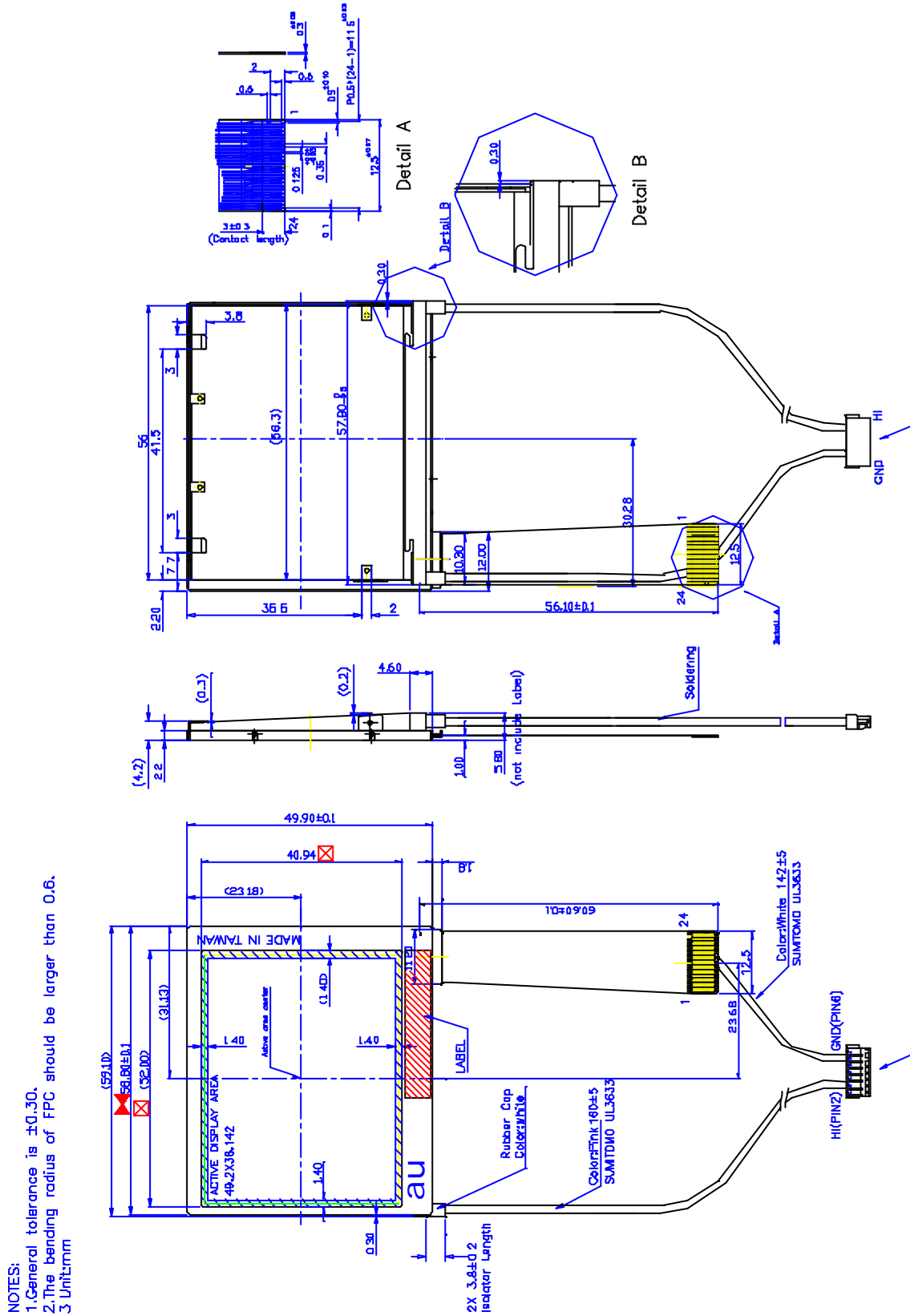

Fig.1 Outline dimension of TFT-LCD module

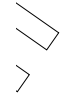
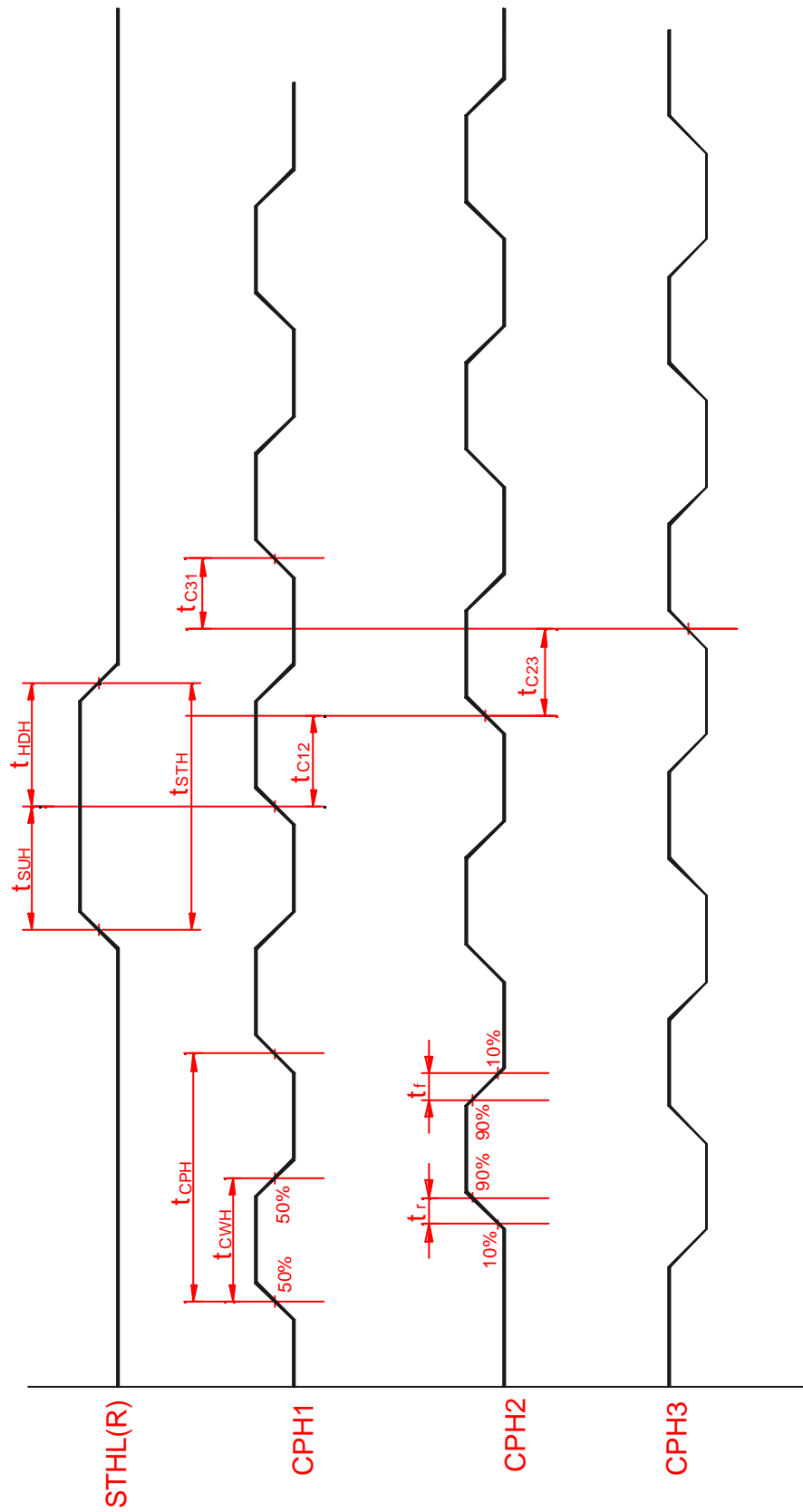

Fig.2 Sampling clock timing

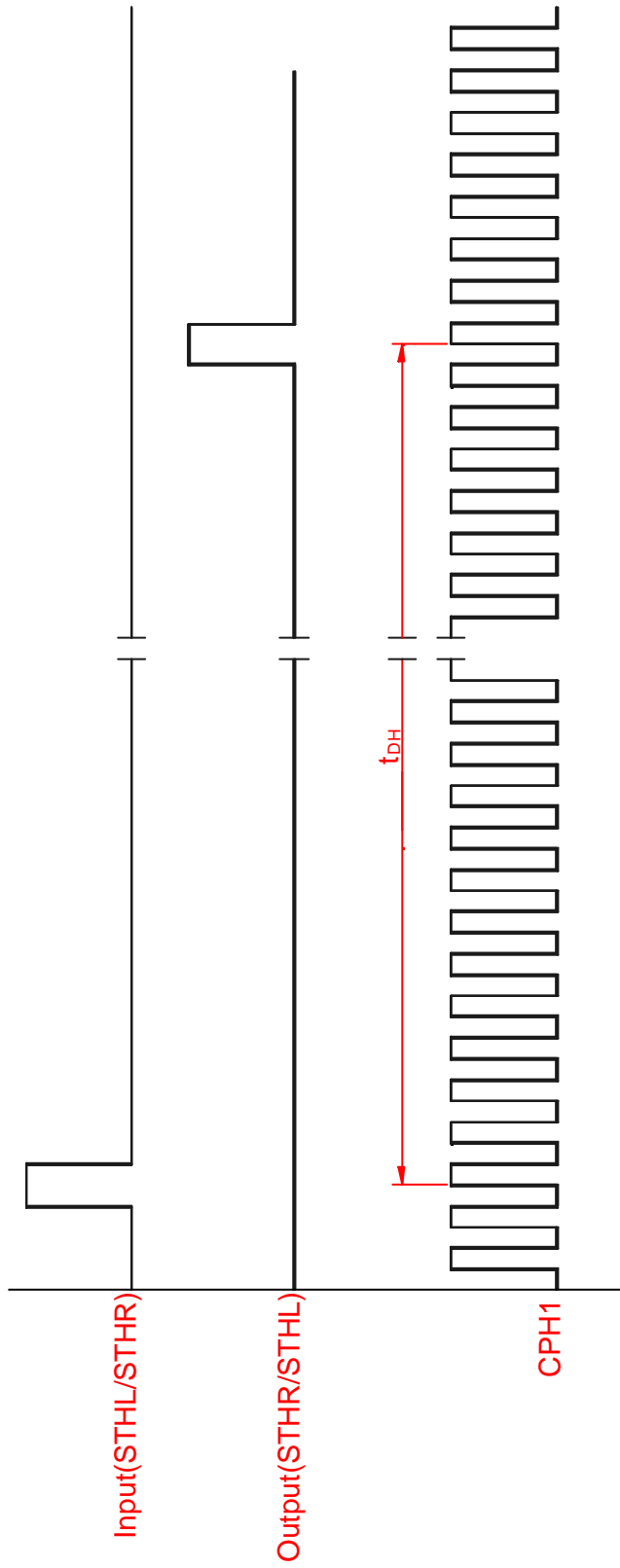

Fig.3 Horizontal display timing range



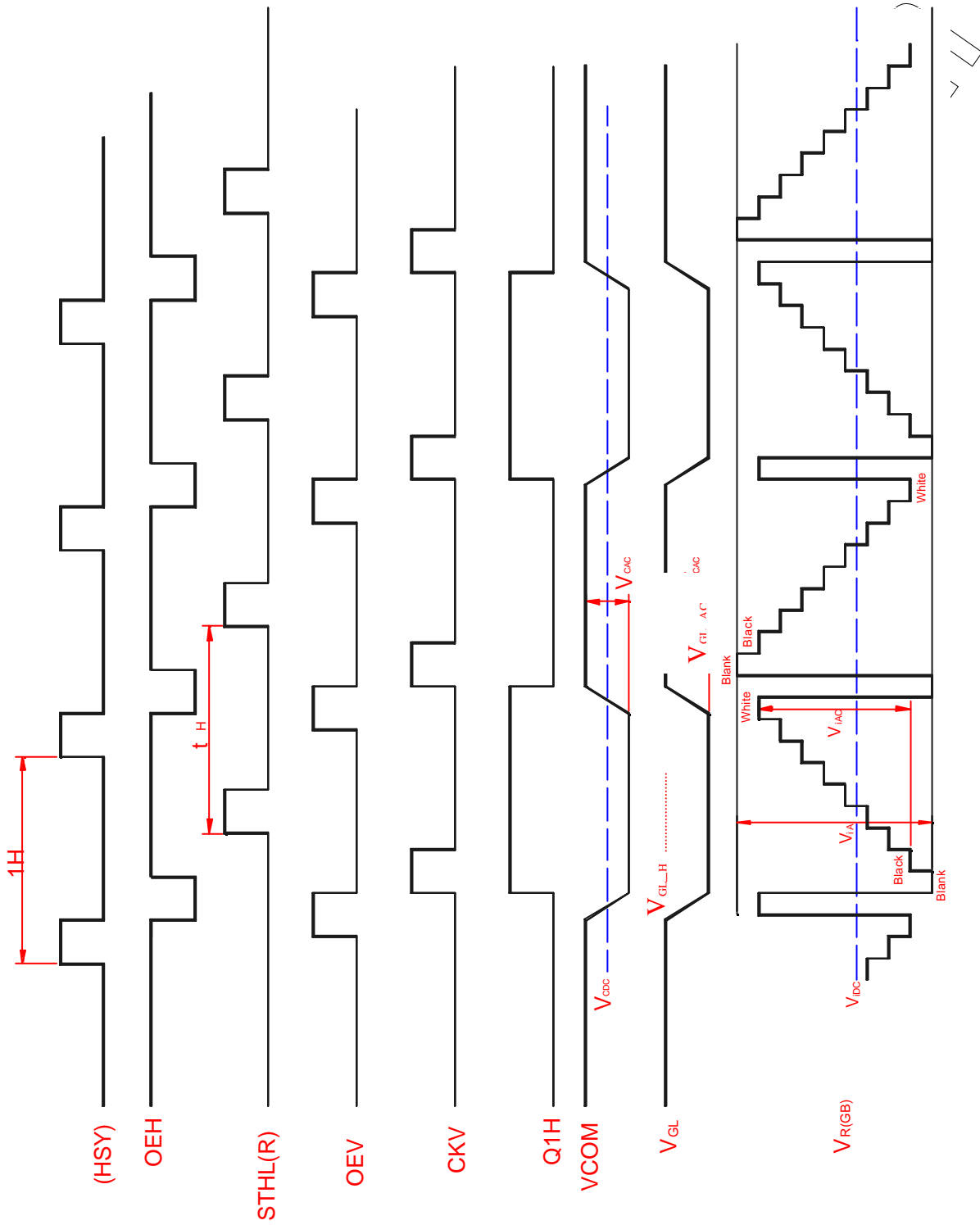

Fig.4(a) Horizontal timing

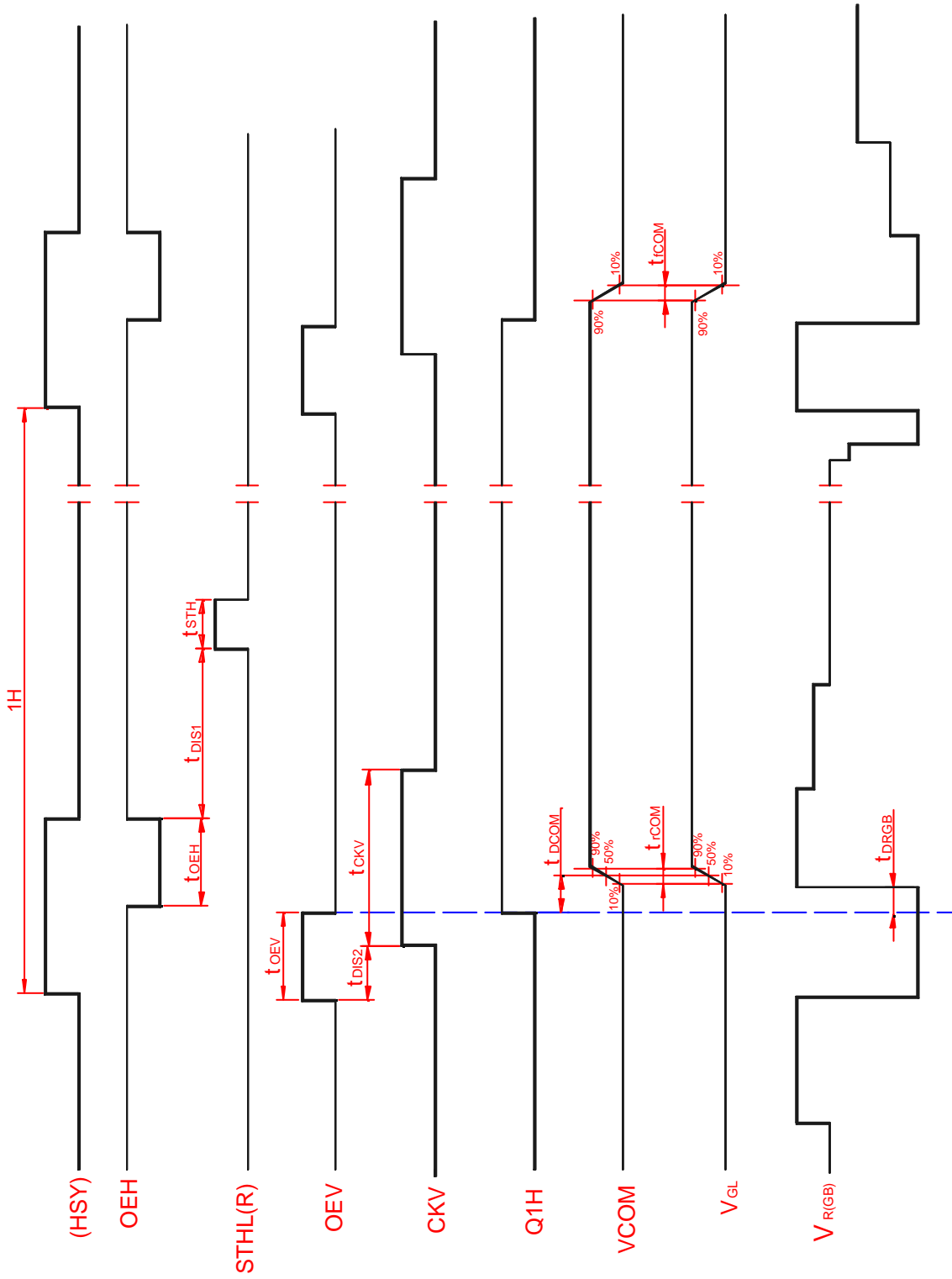

Fig.4-(b) Detail horizontal timing

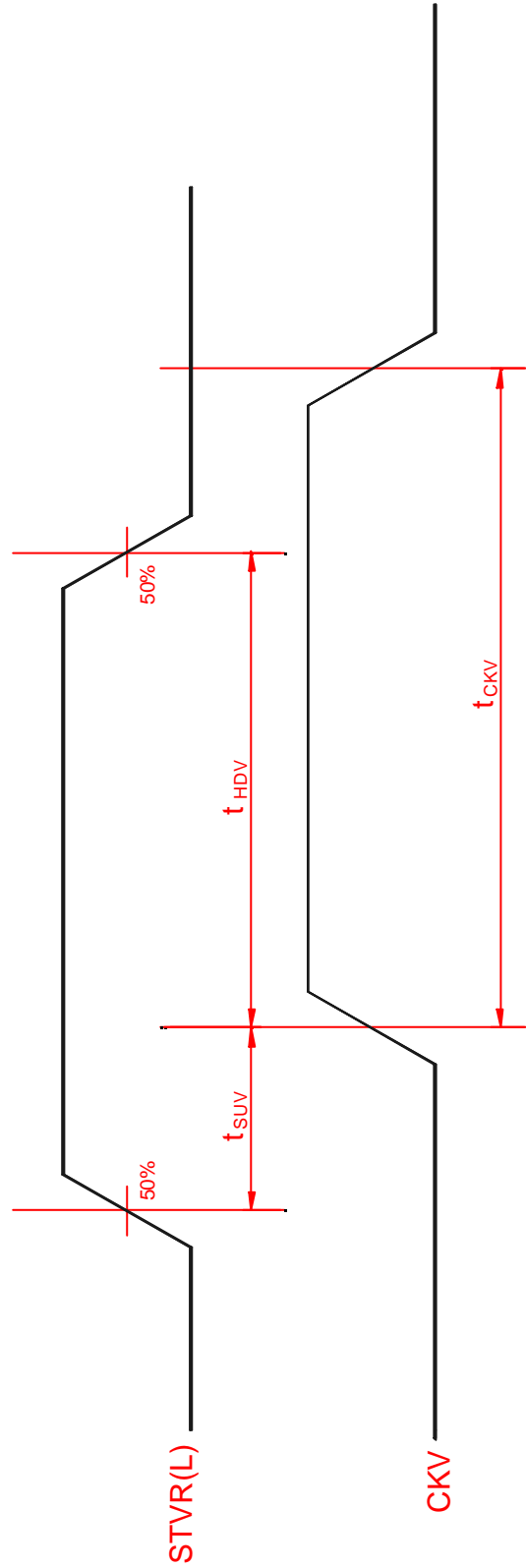

Fig.5 Vertical shift clock timing

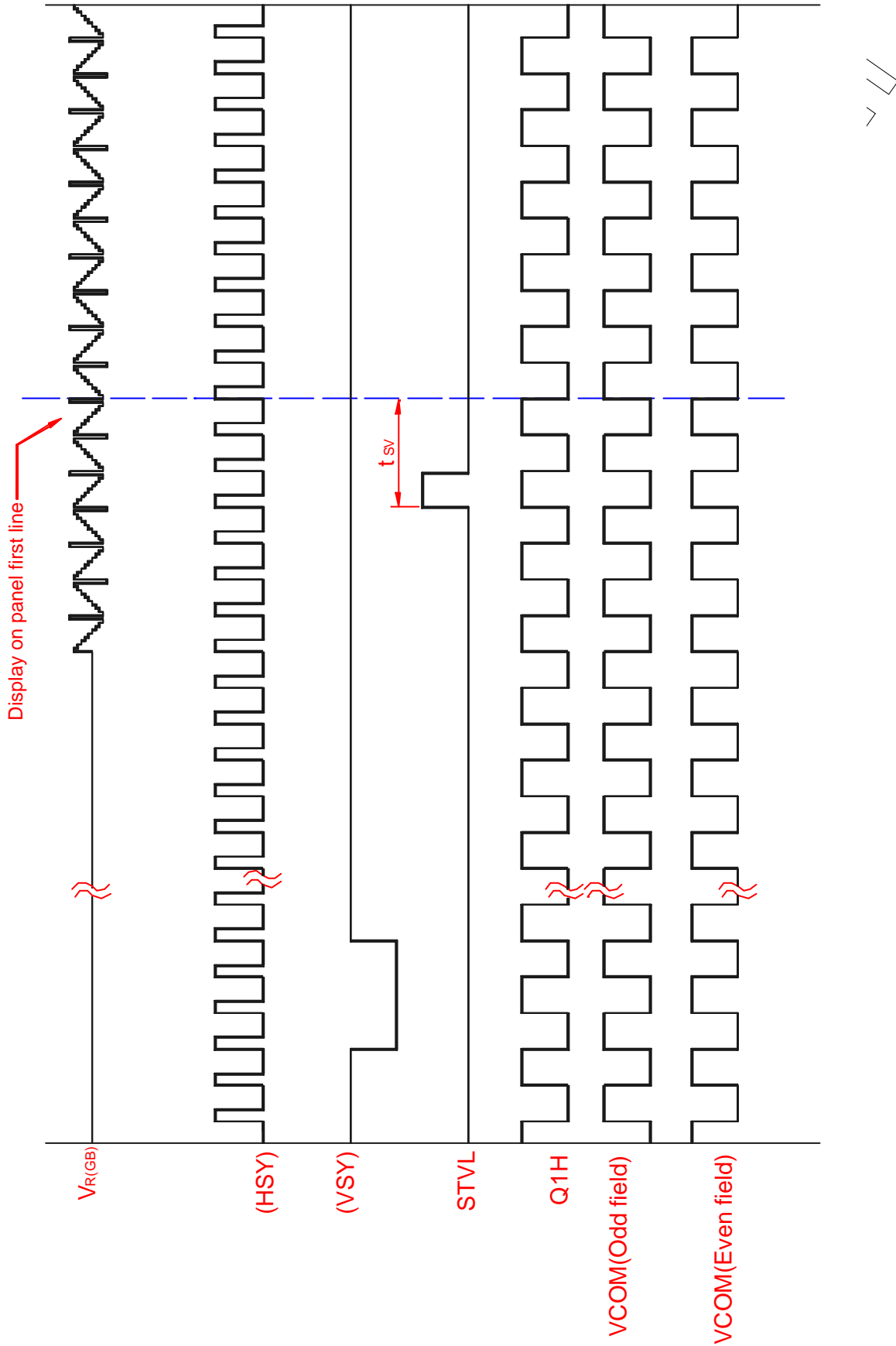

Fig.6-(a) Vertical timing (From up to down)

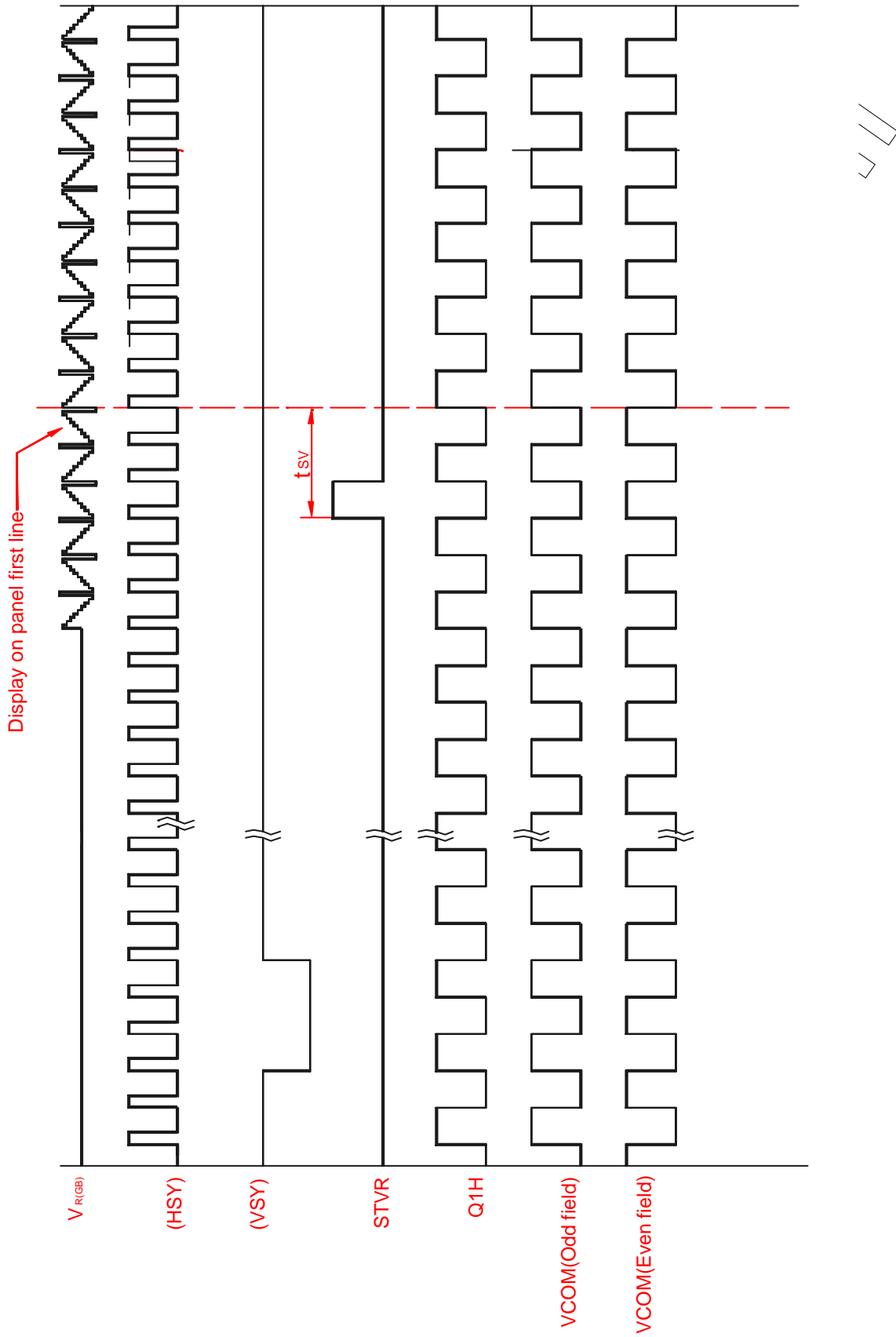

Fig.6-(b) Vertical timing (From down to up)