

IR Receiver Modules for Remote Control Systems

Description

The TSOP362.. - series are miniaturized SMD-IR Receiver Modules for infrared remote control systems. PIN diode and preamplifier are assembled on lead frame, the epoxy package is designed as IR filter.

The demodulated output signal can directly be decoded by a microprocessor. TSOP362.. is the standard IR remote control SMD-Receiver series, for 3 V supply voltage supporting all major transmission codes.

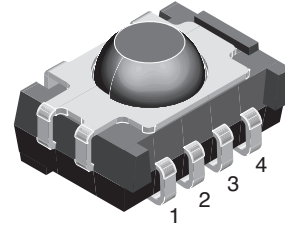

16797

Features

- Photo detector and preamplifier in one package
- Internal filter for PCM frequency
- Continuous data transmission possible
- TTL and CMOS compatibility
- Output active low
- Low power consumption
- High immunity against ambient light
- Supply voltage: 2.7 V to 5.5 V



Mechanical Data

Pinning:

1 = GND, 2 = GND, 3 = V_S, 4 = OUT

Parts Table

Part	Carrier Frequency
TSOP36230	30 kHz
TSOP36233	33 kHz
TSOP36236	36 kHz
TSOP36237	36.7 kHz
TSOP36238	38 kHz
TSOP36240	40 kHz
TSOP36256	56 kHz

Special Features

- Improved immunity against ambient light
- Suitable burst length (≥ 10 cycles/burst)
- Taping available for topview and sideview assembly

www.vishay.com

Block Diagram

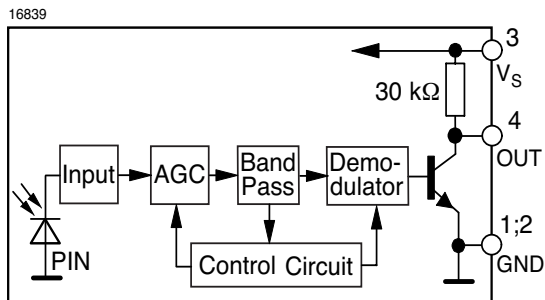

Application Circuit

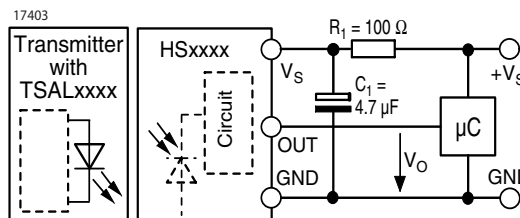

$R_1 + C_1$ recommended to suppress power supply disturbances.

The output voltage should not be held continuously at a voltage below $V_O = 2.0$ V by the external circuit.

Absolute Maximum Ratings

Absolute Maximum Ratings

$T_{amb} = 25$ °C, unless otherwise specified

Parameter	Test condition	Symbol	Value	Unit
Supply Voltage	Pin 3	V_S	- 0.3 to + 6.0	V
Supply Current	Pin 3	I_S	3	mA
Output Voltage	Pin 4	V_O	- 0.3 to $(V_S + 0.3)$	V
Output Current	Pin 4	I_O	10	mA
Junction Temperature		T_j	100	°C
Storage Temperature Range		T_{stg}	- 40 to + 100	°C
Operating Temperature Range		T_{amb}	- 25 to + 85	°C
Power Consumption	$T_{amb} \leq 85$ °C	P_{tot}	30	mW

Electrical and Optical Characteristics

$T_{amb} = 25$ °C, unless otherwise specified

Parameter	Test condition	Symbol	Min	Typ.	Max	Unit
Supply Current	$E_v = 0$	I_{SD}	0.7	1.2	1.5	mA
	$E_v = 40$ klx, sunlight	I_{SH}		1.3		mA
Supply Voltage		V_S	2.7		5.5	V
Transmission Distance	$E_v = 0$, test signal see fig.1, IR diode TSAL6200, $I_f = 250$ mA	d		35		m
Output Voltage Low	$I_{OSL} = 0.5$ mA, $E_e = 0.7$ mW/m ² , test signal see fig. 1	V_{OSL}			250	mV
Minimum Irradiance (30 - 40 kHz)	$V_S \geq 3$ V Pulse width tolerance: $t_{pi} - 5/f_o < t_{po} < t_{pi} + 6/f_o$, test signal see fig.1	$E_{e\ min}$		0.35	0.5	mW/m ²

Parameter	Test condition	Symbol	Min	Typ.	Max	Unit
Minimum Irradiance (56 kHz)	$V_S = 3\text{ V}$ Pulse width tolerance: $t_{pi} - 5/f_o < t_{po} < t_{pi} + 6/f_o$, test signal see fig.1	$E_{e\ min}$		0.4	0.6	mW/m^2
Minimum Irradiance (30 - 40 kHz)	$V_S = 5\text{ V}$ Pulse width tolerance: $t_{pi} - 5/f_o < t_{po} < t_{pi} + 6/f_o$, test signal see fig.1	$E_{e\ min}$		0.45	0.6	mW/m^2
Minimum Irradiance (56 kHz)	$V_S = 5\text{ V}$ Pulse width tolerance: $t_{pi} - 5/f_o < t_{po} < t_{pi} + 6/f_o$, test signal see fig.1	$E_{e\ min}$		0.5	0.7	mW/m^2
Maximum Irradiance	$t_{pi} - 5/f_o < t_{po} < t_{pi} + 6/f_o$, test signal see fig. 3	$E_{e\ max}$	30			W/m^2
Directivity	Angle of half transmission distance	$\varphi_{1/2}$		± 45		deg

Typical Characteristics ($T_{amb} = 25\text{ }^\circ\text{C}$ unless otherwise specified)

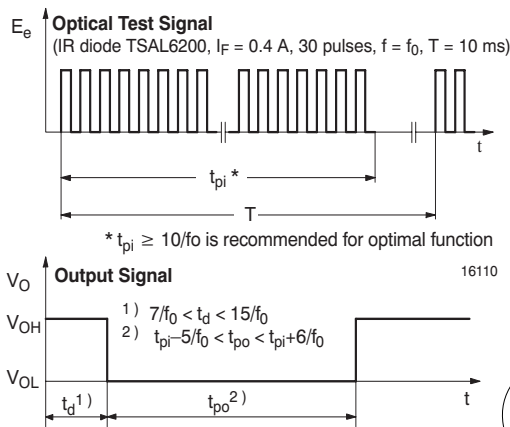

Figure 1. Output Function

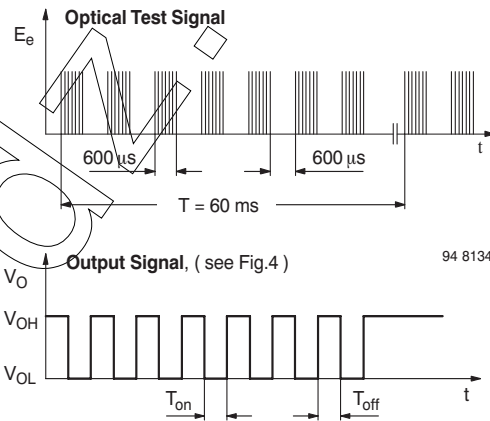

Figure 3. Output Function

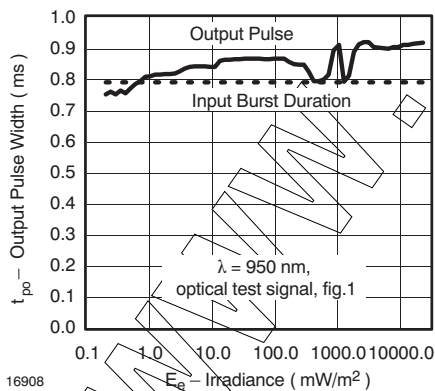

Figure 2. Pulse Length and Sensitivity in Dark Ambient

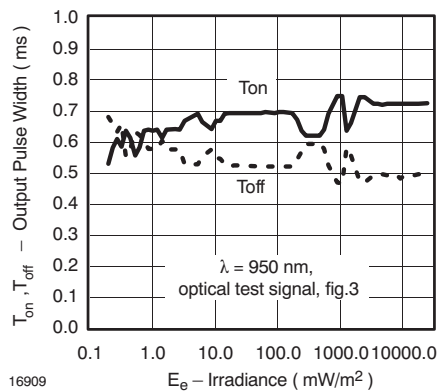

Figure 4. Output Pulse Diagram

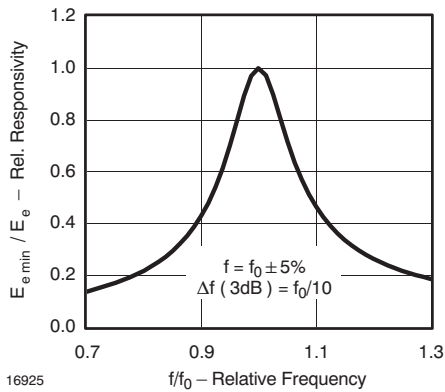

Figure 5. Frequency Dependence of Responsivity

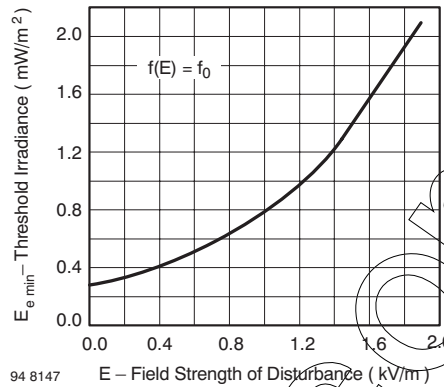

Figure 8. Sensitivity vs. Electric Field Disturbances

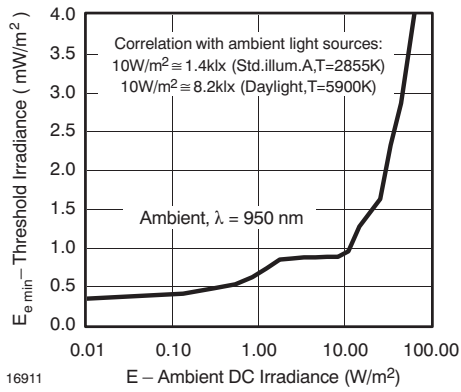

Figure 6. Sensitivity in Bright Ambient

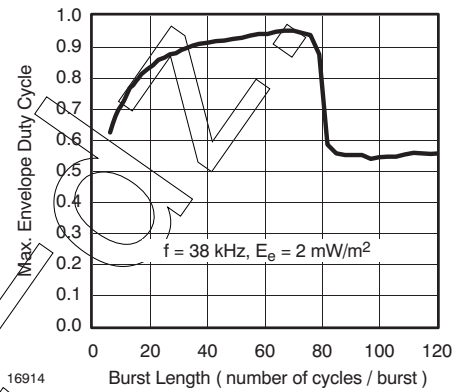

Figure 9. Max. Envelope Duty Cycle vs. Burstlength

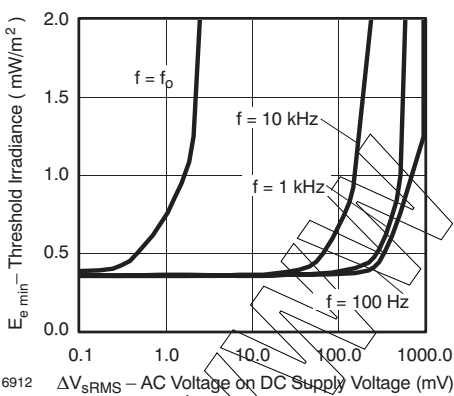

Figure 7. Sensitivity vs. Supply Voltage Disturbances

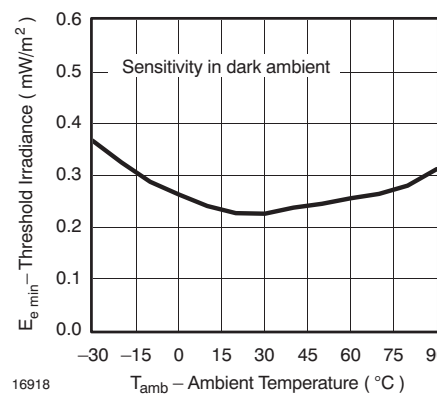

Figure 10. Sensitivity vs. Ambient Temperature

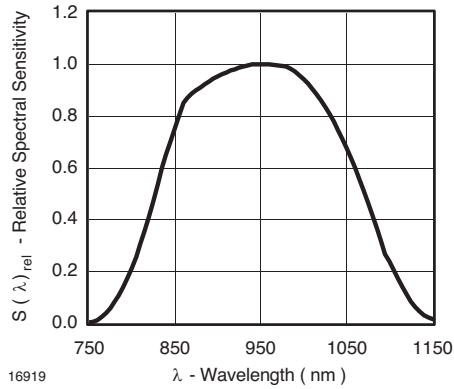

Figure 11. Relative Spectral Sensitivity vs. Wavelength

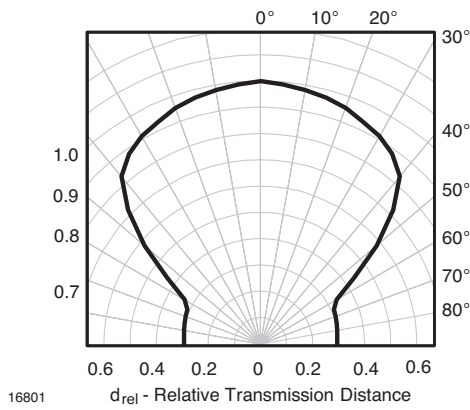

Figure 12. Directivity

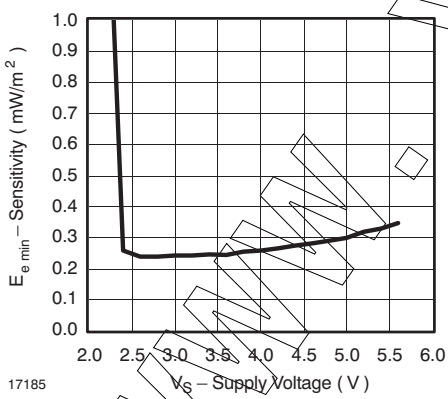

Figure 13. Sensitivity vs. Supply Voltage

Suitable Data Format

The circuit of the TSOP362.. is designed in that way that unexpected output pulses due to noise or disturbance signals are avoided. A bandpass filter, an integrator stage and an automatic gain control are used to suppress such disturbances.

The distinguishing mark between data signal and disturbance signal are carrier frequency, burst length and duty cycle.

The data signal should fulfill the following conditions:

- Carrier frequency should be close to center frequency of the bandpass (e.g. 38 kHz).
- Burst length should be 10 cycles/burst or longer.
- After each burst which is between 10 cycles and 70 cycles a gap time of at least 14 cycles is necessary.
- For each burst which is longer than 1.8 ms a corresponding gap time is necessary at some time in the data stream. This gap time should be at least 6 times longer than the burst.
- Up to 800 short bursts per second can be received continuously.

Some examples for suitable data format are: NEC Code (repetitive pulse), NEC Code (repetitive data), Toshiba Micom Format, Sharp Code, RC5 Code, RC6 Code, R-2000 Code, Sony Code.

When a disturbance signal is applied to the TSOP362.. it can still receive the data signal. However the sensitivity is reduced to that level that no unexpected pulses will occur.

Some examples for such disturbance signals which are suppressed by the TSOP362.. are:

- DC light (e.g. from tungsten bulb or sunlight)
- Continuous signal at 38 kHz or at any other frequency
- Signals from fluorescent lamps with electronic ballast with high or low modulation (see Figure 14 or 15).

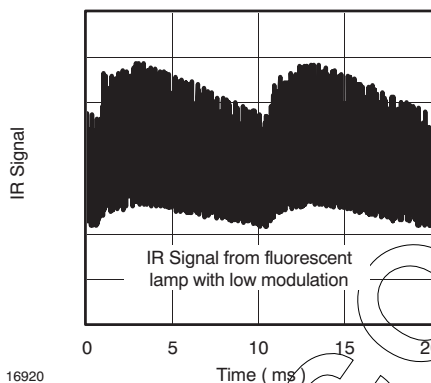

Figure 14. IR Signal from Fluorescent Lamp with low Modulation

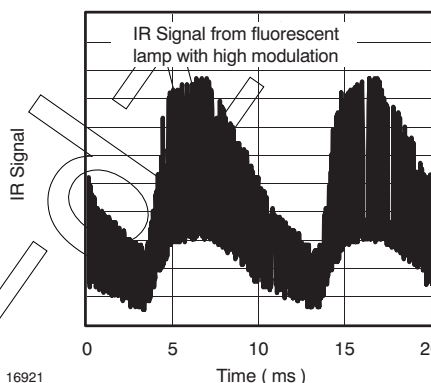
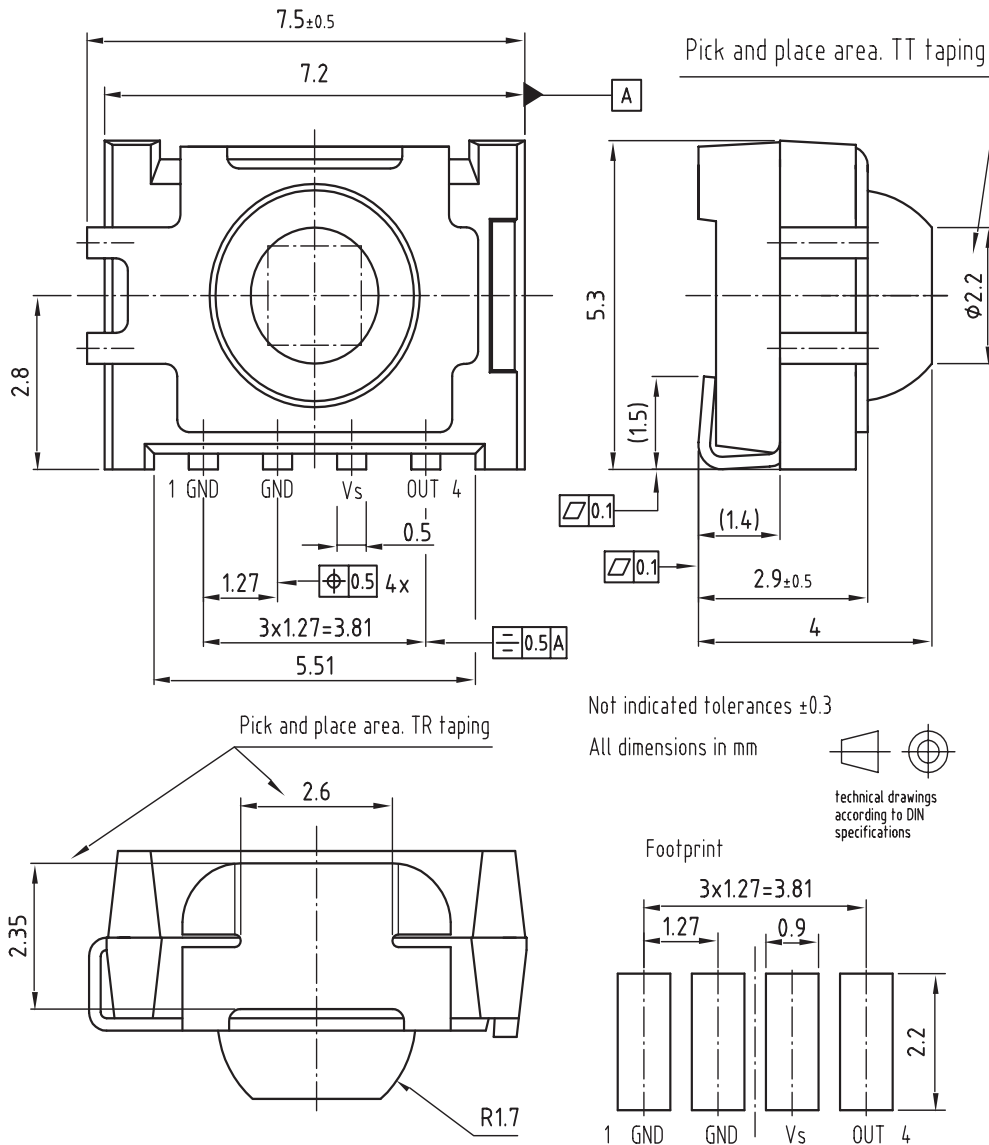

Figure 15. IR Signal from Fluorescent Lamp with high Modulation

Package Dimensions in mm



Drawing-No.: 6.544-5341.02-4
Issue: 5; 30.09.03

16629

Assembly Instructions

Reflow Soldering

- Reflow soldering must be done within 72 hours stored under max. 30 °C, 60 % RH after opening envelop

- Recommended soldering paste (composition: SN 63 %, Pb 37 %) Melting temperature 178 °C to 192 °C
- Apply solder paste to the specified soldering pads, by using a dispenser or by screen printing.

- Recommended thickness of metal mask is 0.2 mm for screen printing.
- The recommended reflow furnace is a combination-type with upper and lower heaters.
- Set the furnace temperatures for pre-heating and heating in accordance with the reflow temperature profile as shown below. Exercise extreme care to keep the maximum temperature below 230 °C. The following temperature profile means the temperature at the device surface. Since temperature difference occurs between the work and the surface of the circuit board depending on the position of circuit board or reflow furnace, the operating conditions should be verified prior to start of operation.
- Handling after reflow should be done only after the work surface has been cooled off.

Reflow Solder Profile

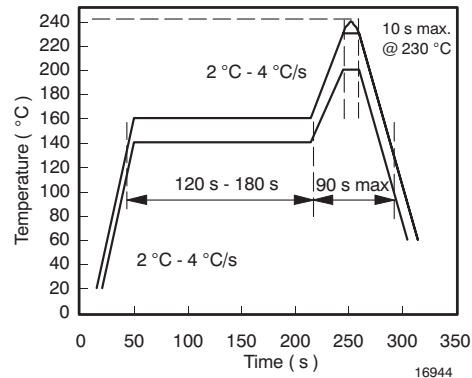

Manual Soldering

- Use the 6/4 solder or the solder containing silver.
- Use a soldering iron of 25 W or smaller. Adjust the temperature of the soldering iron below 300 °C.
- Finish soldering within three seconds.
- Handle products only after the temperature is cooled off.

Cleaning

- Perform cleaning after soldering strictly in conformance to the following conditions:

Cleaning agent:

2-propanol (isopropyl alcohol)

Commercially available grades (industrial use) should be used.

Demineralized or distilled water having a resistivity of not less than 500 mΩ corresponding to a conductivity of 2 mS/m.

- Temperature and time: 30 seconds under the temperature below 50 °C or 3 minutes below 30 °C.
- Ultrasonic cleaning: Below 20 W.

Taping Version TSOP..TT

technical drawings
according to DIN
specifications

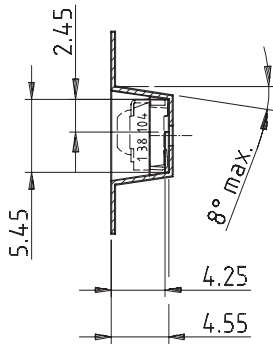

Drawing-No.: 9.700-5259.01-4
Issue: 1; 05.09.01

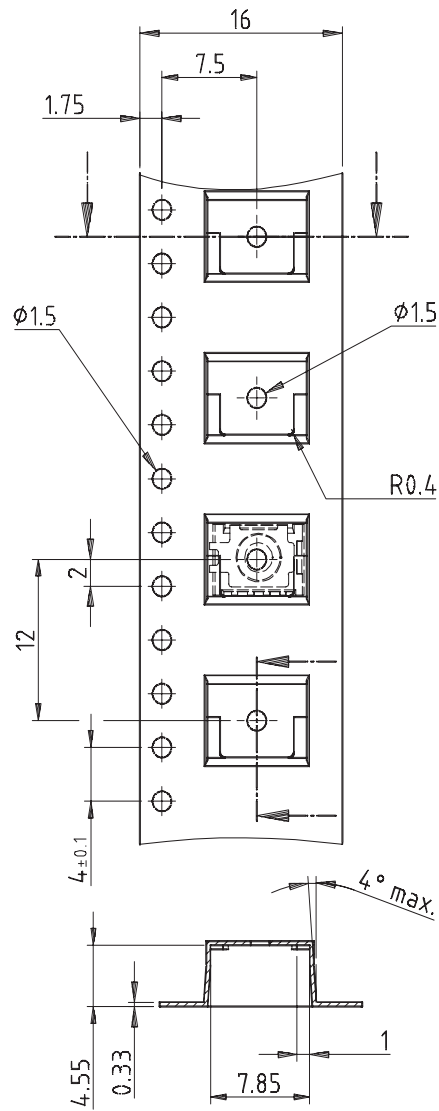

16584

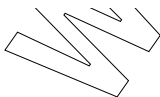

Taping Version TSOP..TR

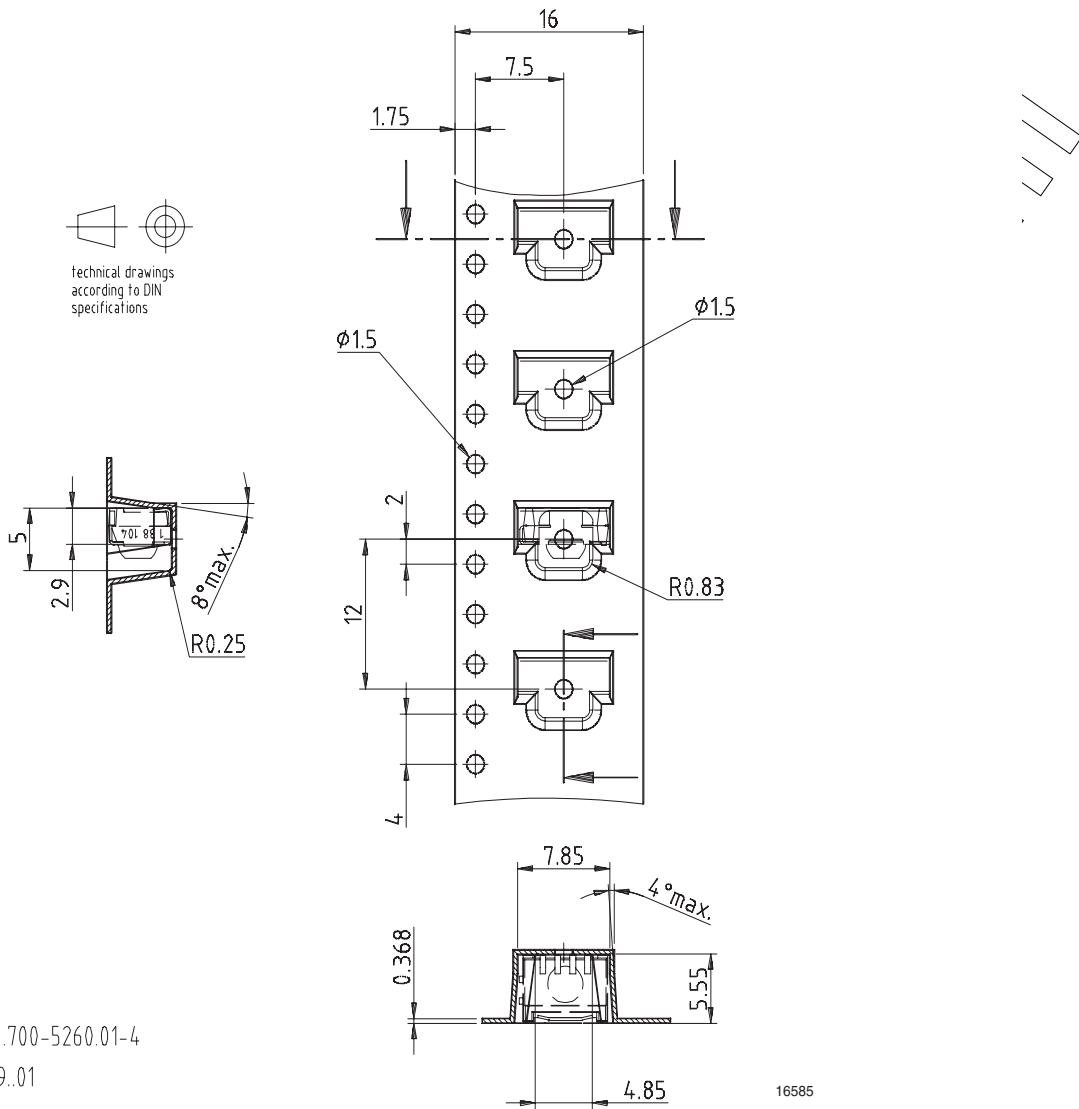

Drawing-No.: 9.700-5260.01-4
Issue: 2; 25.09..01

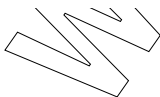

Reel Dimensions

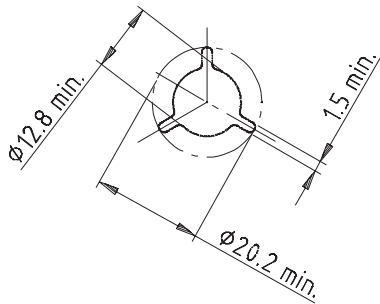
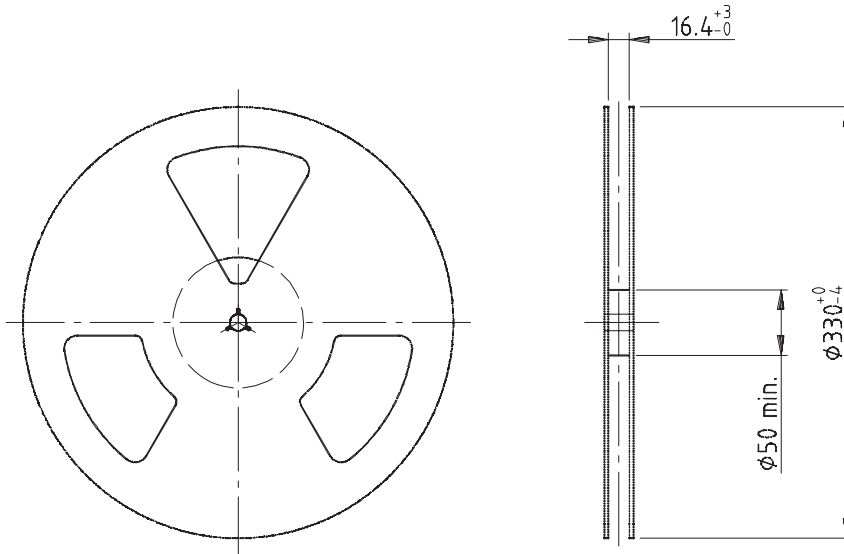

Reel hub 2:1

Form of the leave open of the wheel is supplier specific.

Dimension acc. to IEC EN 60 286-3

Tape width 16

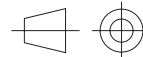

technical drawings according to DIN specifications

Drawing refers to following types: Reel for blister carrier tape Version B

16734

Drawing-No.: 9.800-5052.V2-4

Issue: 1; 07.05.02

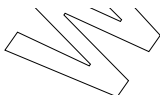

Leader and Trailer

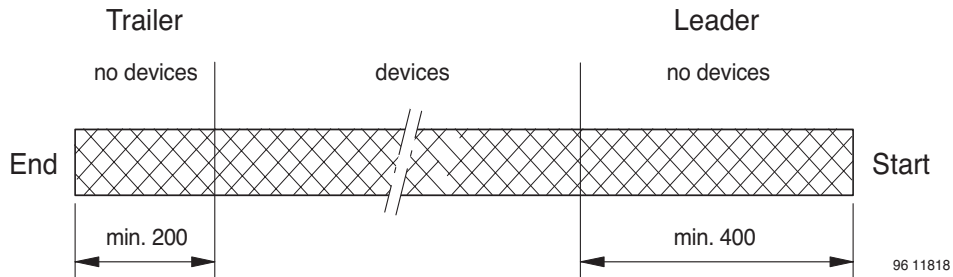

Cover Tape Peel Strength

According to DIN EN 60286-3

0.1 to 1.3 N

300 ± 10 mm/min

165 ° - 180 ° peel angle

Label

Standard bar code labels for finished goods

The standard bar code labels are product labels and used for identification of goods. The finished goods are packed in final packing area. The standard packing units are labeled with standard bar code labels before transported as finished goods to warehouses. The labels are on each packing unit and contain Vishay Semiconductor GmbH specific data.

Vishay Semiconductor GmbH standard bar code product label (finished goods)

Plain Writing	Abbreviation	Length
Item-Description	–	18
Item-Number	INO	8
Selection-Code	SEL	3
LOT-/ Serial-Number	BATCH	10
Data-Code	COD	3 (YWW)
Plant-Code	PTC	2
Quantity	QTY	8
Accepted by:	ACC	–
Packed by:	PCK	–
Mixed Code Indicator	MIXED CODE	–
Origin	xxxxxxx ⁺	Company Logo

Long Bar Code Top	Type	Length
Item-Number	N	8
Plant-Code	N	2
Sequence-Number	X	3
Quantity	N	8
Total Length	–	21

Short Bar Code Bottom	Type	Length
Selection-Code	X	3
Data-Code	N	3
Batch-Number	X	10
Filter	–	1
Total Length	–	17

16942

Dry Packing

The reel is packed in an anti-humidity bag to protect the devices from absorbing moisture during transportation and storage.

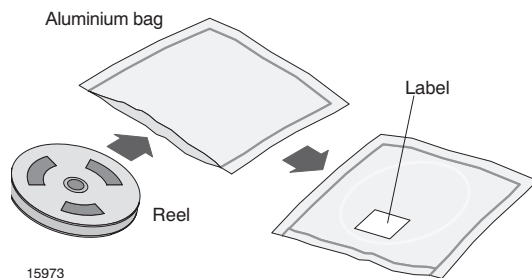

15973

Final Packing

The sealed reel is packed into a cardboard box. A secondary cardboard box is used for shipping purposes.

Recommended Method of Storage

Dry box storage is recommended as soon as the aluminium bag has been opened to prevent moisture absorption. The following conditions should be observed, if dry boxes are not available:

- Storage temperature 10 °C to 30 °C
- Storage humidity ≤ 60 % RH max.

After more than 72 hours under these conditions moisture content will be too high for reflow soldering. In case of moisture absorption, the devices will recover to the former condition by drying under the following condition:

192 hours at 40 °C + 5 °C/ -0 °C and < 5 % RH (dry air/ nitrogen) or

96 hours at 60 °C +5 °C and < 5 % RH for all device containers or

24 hours at 125 °C +5 °C not suitable for reel or tubes.

An EIA JEDEC Standard JESD22-A112 Level 4 label is included on all dry bags.



16962

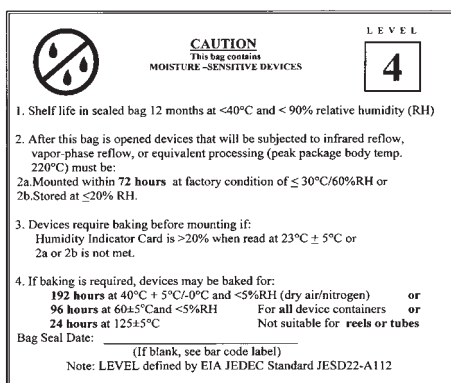

Example of JESD22-A112 Level 4 label

ESD Precaution

Proper storage and handling procedures should be followed to prevent ESD damage to the devices especially when they are removed from the Antistatic Shielding Bag. Electro-Static Sensitive Devices warning labels are on the packaging.

Vishay Semiconductors Standard Bar-Code Labels

The Vishay Semiconductors standard bar-code labels are printed at final packing areas. The labels are on each packing unit and contain Vishay Telefunken specific data.

Ozone Depleting Substances Policy Statement

It is the policy of Vishay Semiconductor GmbH to

1. Meet all present and future national and international statutory requirements.
2. Regularly and continuously improve the performance of our products, processes, distribution and operating systems with respect to their impact on the health and safety of our employees and the public, as well as their impact on the environment.

It is particular concern to control or eliminate releases of those substances into the atmosphere which are known as ozone depleting substances (ODSs).

The Montreal Protocol (1987) and its London Amendments (1990) intend to severely restrict the use of ODSs and forbid their use within the next ten years. Various national and international initiatives are pressing for an earlier ban on these substances.

Vishay Semiconductor GmbH has been able to use its policy of continuous improvements to eliminate the use of ODSs listed in the following documents.

1. Annex A, B and list of transitional substances of the Montreal Protocol and the London Amendments respectively
2. Class I and II ozone depleting substances in the Clean Air Act Amendments of 1990 by the Environmental Protection Agency (EPA) in the USA
3. Council Decision 88/540/EEC and 91/690/EEC Annex A, B and C (transitional substances) respectively.

Vishay Semiconductor GmbH can certify that our semiconductors are not manufactured with ozone depleting substances and do not contain such substances.

We reserve the right to make changes to improve technical design and may do so without further notice.

Parameters can vary in different applications. All operating parameters must be validated for each customer application by the customer. Should the buyer use Vishay Semiconductors products for any unintended or unauthorized application, the buyer shall indemnify Vishay Semiconductors against all claims, costs, damages, and expenses, arising out of, directly or indirectly, any claim of personal damage, injury or death associated with such unintended or unauthorized use.

Vishay Semiconductor GmbH, P.O.B. 3535, D-74025 Heilbronn, Germany
Telephone: 49 (0)7131 67 2831, Fax number: 49 (0)7131 67 2423