

IrDA® Compliant 4 Mb/s 3 V Infrared Transceiver

Technical Data

HSDL-3600#007
HSDL-3600#008
HSDL-3600#107

Features

- **Fully Compliant to IrDA 1.1 Physical Layer Specifications**
 - 9.6 kb/s to 4 Mb/s operation
- **Typical Link Distance > 1.5 m**
- **Compatible with HP-SIR and TV Remote**
- **IEC825-Class 1 Eye Safe**
- **Low Power Operation**
 - 2.7 V to 3.6 V
- **Small Module Size**
 - 4.0 x 12.2 x 5.1 mm (HxWxD)
- **Complete Shutdown**
 - TXD, RXD, PIN diode
- **Low Shutdown Current**
 - 10 nA typical
- **Adjustable Optical Power Management**
 - Adjustable LED drive-current to maintain link integrity
- **Single Rx Data Output**
 - Speed select by FIR Select pin
- **Integrated EMI Shield**
 - Excellent noise immunity
- **Edge Detection Input**
 - Prevents the LED from long turn-on time
- **Interface to Various Super I/O and Controller Devices**
- **Designed to Accommodate Light Loss with Cosmetic Window**
- **Only 2 External Components are Required**

Applications

- **Digital Imaging**
 - Digital Still Cameras
 - Photo-Imaging Printers
- **Data Communication**
 - Notebook Computers
 - Desktop PCs
 - Win CE Handheld Products
 - Personal Digital Assistants (PDAs)
 - Printers
 - Fax Machines, Photocopiers
 - Screen Projectors
 - Auto PCs
 - Dongles
 - Set-Top Box
- **Telecommunication Products**
 - Cellular Phones
 - Pagers
- **Small Industrial & Medical Instrumentation**
 - General Data Collection Devices
 - Patient & Pharmaceutical Data Collection Devices
- **IR LANs**

Description

The HSDL-3600 is a low-profile infrared transceiver module that provides interface between logic and IR signals for through-air, serial, half-duplex IR data link. The module is compliant to IrDA Data Physical Layer Specifications 1.1 and IEC825-Class 1 Eye Safe.



Functional Block Diagram

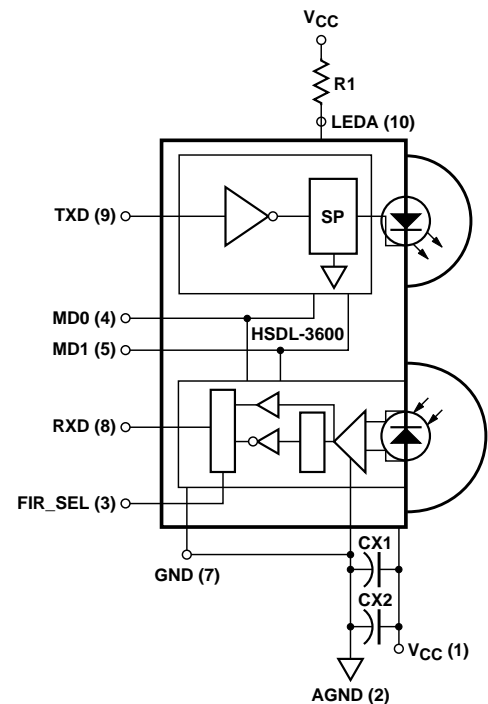

The HSDL-3600 contains a high-speed and high-efficiency 870 nm LED, a silicon PIN diode, and an integrated circuit. The IC contains an LED driver and a receiver providing a single output (RXD) for all data rates supported.

The HSDL-3600 can be completely shut down to achieve very low power consumption. In the shut down mode, the PIN diode will be inactive and thus producing very little photo-current even under very bright ambient light. The HSDL-3600 also incorporated the capability





for adjustable optical power. With two programming pins; MODE 0 and MODE 1, the optical power output can be adjusted lower when the nominal desired link distance is one-third or two-third of the full IrDA link.

The HSDL-3600 comes in three package options; the front view option (HSDL-3600#007/#017), the front view guide pin option (HSDL-3600#107/#117), and the top view option (HSDL-3600#008/#018). All options come with integrated shield that helps to ensure low EMI emission and high immunity to EMI field, thus enhancing reliable performance.

Application Support Information

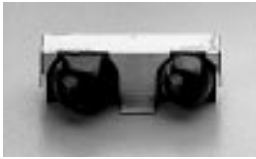
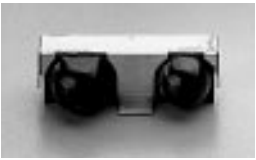
The Application Engineering group is available to assist you with the technical understanding associated with HSDL-3600 infrared transceiver module. You can contact them through your local sales representatives for additional details.

Ordering Information

Package Option	Package	Part Number	Standard Package Increment
	Front View	HSDL-3600#007	400
	Front View	HSDL-3600#017	10
	Top View	HSDL-3600#008	400
	Top View	HSDL-3600#018	10
	Front View (with guide pin)	HSDL-3600#107	300
	Front View (with guide pin)	HSDL-3600#117	10

Functional Block Diagram

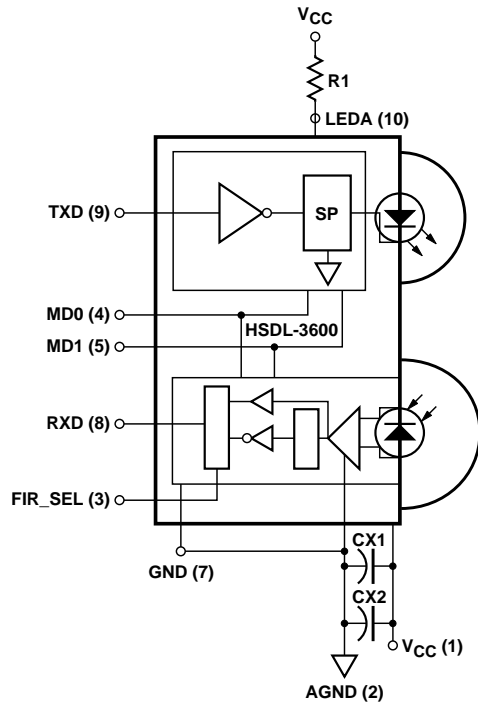

I/O Pins Configuration Table

Pin	Description	Symbol
1	Supply Voltage	VCC
2	Analog Ground	AGND
3	FIR Select	FIR_SEL
4	Mode 0	MD0
5	Mode 1	MD1
6	No Connection	NC
7	Ground	GND
8	Receiver Data Output	RXD
9	Transmitter Data Input	TXD
10	LED Anode	LEDA

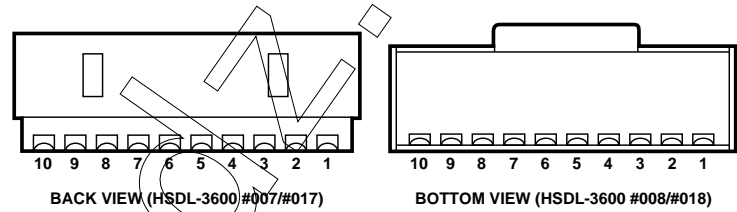

Transceiver Control Truth Table

Mode 0	Mode 1	FIR_SEL	RX Function	TX Function
1	0	X	Shutdown	Shutdown
0	0	0	SIR	Full Distance Power
0	1	0	SIR	2/3 Distance Power
1	1	0	SIR	1/3 Distance Power
0	0	1	MIR/FIR	Full Distance Power
0	1	1	MIR/FIR	2/3 Distance Power
1	1	1	MIR/FIR	1/3 Distance Power

X = Don't Care

Transceiver I/O Truth Table

Transceiver Mode	FIR_SEL	Inputs		Outputs	
		TXD	EI	LED	RXD
Active	X	1	X	On	Not Valid
Active	0	0	High ^[1]	Off	Low ^[3]
Active	1	0	High ^[2]	Off	Low ^[3]
Active	X	0	Low	Off	High
Shutdown	X	X ^[4]	Low	Not Valid	Not Valid

X = Don't Care EI = In-Band Infrared Intensity at detector

Notes :

1. In-Band EI \leq 115.2 kb/s and FIR_SEL = 0.
2. In-Band EI \geq 0.576 Mb/s and FIR_SEL = 1.
3. Logic Low is a pulsed response. The condition is maintained for duration dependent on the pattern and strength of the incident intensity.
4. To maintain low shutdown current, TXD needs to be driven high or low and not left floating.

Recommended Application Circuit Components

Component	Recommended Value
R1	2.2 Ω \pm 5%, 0.5 Watt, for 2.7 \leq Vcc \leq 3.3 V operation 2.7 Ω \pm 5%, 0.5 Watt, for 3.0 \leq Vcc \leq 3.6 V operation
CX1 ^[5]	0.47 μ F \pm 20%, X7R Ceramic
CX2 ^[6]	6.8 μ F \pm 20%, Tantalum

Notes:

- CX1 must be placed within 0.7 cm of the HSDL-3600 to obtain optimum noise immunity.
- In environments with noisy power supplies, supply rejection performance can be enhanced by including CX2, as shown in "HSDL-3600 Functional Block Diagram" in page 3.

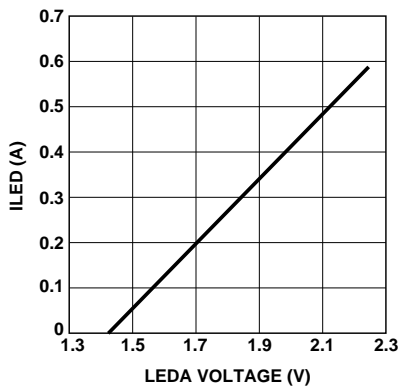

ILED vs. LEDA.

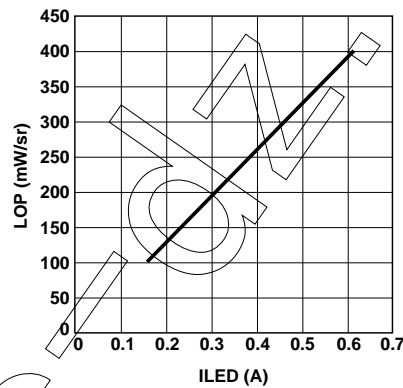

Light Output Power (LOP) vs. ILED.

Marking Information

The HSDL-3600#007/017 is marked "3600YYWW" on the shield where "YY" indicates the unit's manufacturing year, and "WW" refers to the work week in which the unit is tested.

The HSDL-3600#008/018 is marked a "black" dot on the shield.

CAUTIONS: The BiCMOS inherent to the design of this component increases the component's susceptibility to damage from electrostatic discharge (ESD). It is advised that normal static precautions be taken in handling and assembly of this component to prevent damage and/or degradation which may be induced by ESD.

Absolute Maximum Ratings [7]

Parameter	Symbol	Minimum	Maximum	Unit	Conditions
Storage Temperature	T_S	-40	+100	°C	
Operating Temperature	T_A	-20	+70	°C	
DC LED Current	$I_{LED(DC)}$		165	mA	
Peak LED Current	$I_{LED(PK)}$		650	mA	$\leq 90 \mu s$ pulse width, $\leq 25\%$ duty cycle
			750	mA	$\leq 2 \mu s$ pulse width, $\leq 10\%$ duty cycle
LED Anode Voltage	V_{LEDA}	-0.5	7	V	
Supply Voltage	V_{CC}	0	7	V	
Transmitter Data Input Current	$I_{TXD(DC)}$	-12	12	mA	
Receiver Data Output Voltage	V_O	-0.5	$V_{CC}+0.5$	V	$ I_O(RXD) = 20 \mu A$

Note:

7. For implementations where case to ambient thermal resistance $\leq 50^\circ C/W$.

Recommended Operating Conditions

Parameter	Symbol	Min.	Max.	Unit	Conditions
Operating Temperature	T_A	-20	+70	°C	
Supply Voltage	V_{CC}	2.7	3.6	V	
Logic High Input Voltage for TXD, MD0, MD1, and FIR_SEL	V_{IH}	$2 V_{CC}/3$	V_{CC}	V	
Logic Low Transmitter Input Voltage	V_{IL}	0	$V_{CC}/3$	V	
LED (Logic High) Current Pulse Amplitude	I_{LEDA}	400	650	mA	
Receiver Signal Rate		0.0024	4	Mb/s	
Ambient Light					See IrDA Serial Infrared Physical Layer Link Specification, Appendix A for ambient levels

Electrical & Optical Specifications

Specifications hold over the Recommended Operating Conditions unless otherwise noted. Unspecified test conditions can be anywhere in their operating range. All typical values are at 25°C and 3.3 V unless otherwise noted.

Parameter		Symbol	Min.	Typ.	Max.	Unit	Conditions	
Transceiver								
Supply Current	Shutdown	I_{CC1}		10	200	nA	$V_I(\text{TXD}) \leq V_{IL}$ or $V_I(\text{TXD}) \geq V_{IH}$	
	Idle	I_{CC2}		2.5	5	mA	$V_I(\text{TXD}) \leq V_{IL}$, EI = 0	
Digital Input Current	Logic Low/High	$I_{L/H}$	-1		1	μA	$0 \leq V_I \leq V_{CC}$	
Transmitter								
Transmitter Radiant Intensity	Logic High Intensity	IE_H	100	250	400	mW/sr	$V_{IH} = 3.0\text{ V}$ $I_{LEDA} = 400\text{ mA}$ $\theta_{1/2} \leq 15^\circ$	
	Peak Wavelength	λ_P		875		nm		
	Spectral Line Half Width	$\Delta\lambda_{1/2}$		35		nm		
	Viewing Angle	$2\theta_{1/2}$	30		60	°		
	Optical Pulse Width	$tpw(IE)$		1.5	1.6	1.8	μs	$tpw(\text{TXD}) = 1.6\ \mu\text{s}$ at 115.2 kb/s
				148	217	260	ns	$tpw(\text{TXD}) = 217\text{ ns}$ at 1.15 Mb/s
				115	125	135	ns	$tpw(\text{TXD}) = 125\text{ ns}$ at 4.0 Mb/s
Rise and Fall Times	$t_r(IE)$, $t_f(IE)$			40	ns	$tpw(\text{TXD}) = 125\text{ ns}$ at 4.0 Mb/s $t_{r/f}(\text{TXD}) = 10\text{ ns}$		
Maximum Optical Pulse Width	$tpw(\text{max})$		20	50	μs	TXD pin stuck high		
LED Anode On State Voltage	$V_{ON}(\text{LEDA})$			2.4	V	$I_{LEDA} = 400\text{ mA}$, $V_I(\text{TXD}) \geq V_{IH}$		
LED Anode Off State Leakage Current	$I_{LK}(\text{LEDA})$		1	100	nA	$V_{LEDA} = V_{CC} = 3.6\text{ V}$, $V_I(\text{TXD}) \leq V_{IL}$		

Electrical & Optical Specifications

Specifications hold over the Recommended Operating Conditions unless otherwise noted. Unspecified test conditions can be anywhere in their operating range. All typical values are at 25°C and 3.3 V unless otherwise noted.

Parameter		Symbol	Min.	Typ.	Max.	Unit	Conditions
Receiver							
Receiver Data Output Voltage	Logic Low ^[9]	V_{OL}	0	-	0.4	V	$I_{OL} = -1.0 \text{ mA}$, $EI \geq 3.6 \mu\text{W}/\text{cm}^2$, $\theta_{1/2} \leq 15^\circ$
	Logic High	V_{OH}	$V_{CC} - 0.2$	-	V_{CC}	V	$I_{OH} = -20 \mu\text{A}$, $EI \leq 0.3 \mu\text{W}/\text{cm}^2$, $\theta_{1/2} \leq 15^\circ$
	Viewing Angle	$2\theta_{1/2}$	30			°	
Logic High Receiver Input Irradiance		E_{IH}	0.0036 0.0090		500 500	mW/cm^2 mW/cm^2	For in-band signals $\leq 115.2 \text{ kb/s}$ ^[8] $0.576 \text{ Mb/s} \leq$ in-band signals $\leq 4 \text{ Mb/s}$ ^[8]
Logic Low Receiver Input Irradiance		E_{IL}			0.3	$\mu\text{W}/\text{cm}^2$	For in-band signals ^[8]
Receiver Peak Sensitivity Wavelength		λ_P		880		nm	
Receiver SIR Pulse Width		tpw (SIR)	1		4.0	μs	$\theta_{1/2} \leq 15^\circ$ ^[10] , $C_L = 10 \text{ pF}$
Receiver MIR Pulse Width		tpw (MIR)	100		500	ns	$\theta_{1/2} \leq 15^\circ$ ^[11] , $C_L = 10 \text{ pF}$
Receiver FIR Pulse Width		tpw (FIR)	85		165	ns	$\theta_{1/2} \leq 15^\circ$ ^[12] , $C_L = 10 \text{ pF}$, $V_{CC} = 3 - 3.6 \text{ V}$
					190	ns	$\theta_{1/2} \leq 15^\circ$ ^[12] , $C_L = 10 \text{ pF}$, $V_{CC} = 2.7 \text{ V}$
Receiver ASK Pulse Width		tpw (ASK)		1		μs	500 kHz/50% duty cycle carrier ASK ^[13]
Receiver Latency Time for FIR		t_L (FIR)		40	50	μs	
Receiver Latency Time for SIR		t_L (SIR)		20	50	μs	
Receiver Rise/Fall Times		$t_{r/f}$ (RXD)		25		ns	
Receiver Wake Up Time		t_W			100	μs	[14]

Notes :

- An in-band optical signal is a pulse/sequence where the peak wavelength, λ_P , is defined as $850 \leq \lambda_P \leq 900 \text{ nm}$, and the pulse characteristics are compliant with the IrDA Serial Infrared Physical Layer Link Specification.
- Logic Low is a pulsed response. The condition is maintained for duration dependent on pattern and strength of the incident intensity.
- For in-band signals $\leq 115.2 \text{ kb/s}$ where $3.6 \mu\text{W}/\text{cm}^2 \leq EI \leq 500 \text{ mW}/\text{cm}^2$.
- For in-band signals at 1.15 Mb/s where $9.0 \mu\text{W}/\text{cm}^2 \leq EI \leq 500 \text{ mW}/\text{cm}^2$.
- For in-band signals of 125 ns pulse width, 4 Mb/s, 4 PPM at recommended 400 mA drive current.
- Pulse width specified is the pulse width of the second 500 kHz carrier pulse received in a data bit. The first 500 kHz carrier pulse may exceed 2 μs in width, which will not affect correct demodulation of the data stream. An ASK or DASK system using the HSDL-3600 has been shown to correctly receive all data bits for $9 \mu\text{W}/\text{cm}^2 \leq EI \leq 500 \text{ mW}/\text{cm}^2$ incoming signal strength. ASK or DASK should use the FIR channel enabled.
- Wake up time is the time between the transition from a shutdown state to an active state and the time when the receiver is active and ready to receive infrared signals.
- Shields to be grounded.

TXD “Stuck ON” Protection

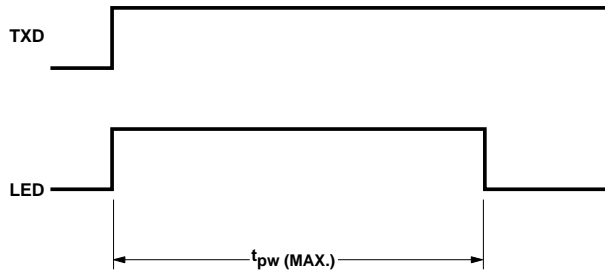

RXD Output Waveform

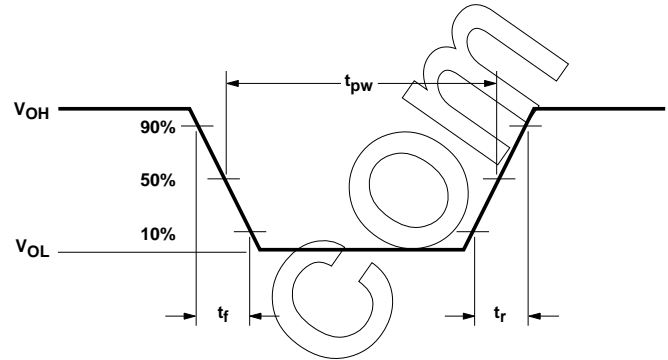

LED Optical Waveform

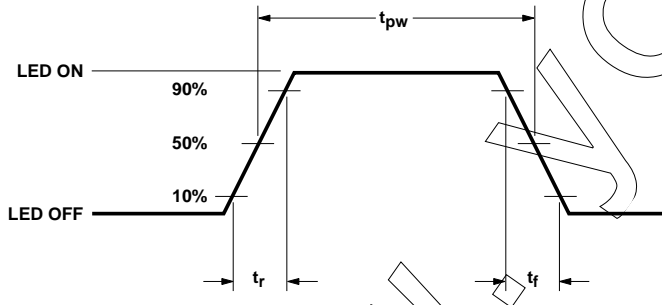

Receiver Wake Up Time Definition (when MD0 \neq 1 and MD1 \neq 0)

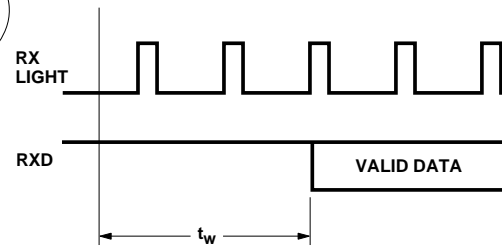

HSDL-3600#007 and HSDL3600#017 Package Outline with Dimension and Recommended PC Board Pad Layout

HSDL-3600#007/#017 (Front Option)

PIN	FUNCTION	PIN	FUNCTION
1	VCC	6	NC
2	AGND	7	GND
3	FIR_SEL	8	RXD
4	MD0	9	TXD
5	MD1	10	LEDA

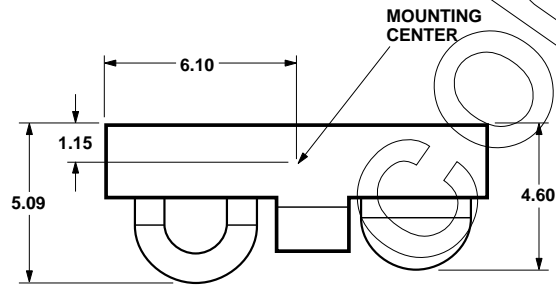

TOP VIEW

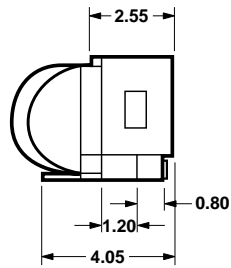

SIDE VIEW

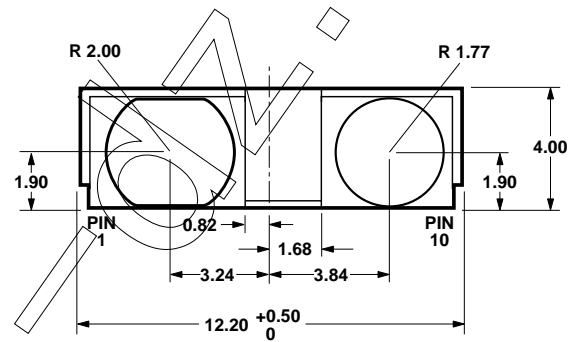

FRONT VIEW

ALL DIMENSIONS IN MILLIMETERS (mm).
DIMENSION TOLERANCE IS 0.20 mm
UNLESS OTHERWISE SPECIFIED.

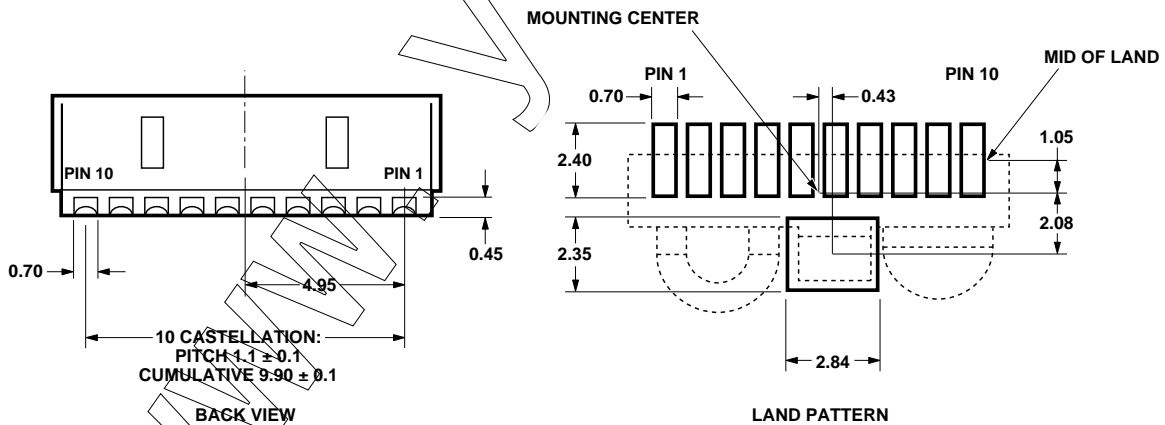

BACK VIEW

LAND PATTERN

HSDL-3600#008 and HSDL3600#018 Package Outline with Dimension and Recommended PC Board Pad Layout

HSDL-3600#008/#018
(Top Option)

PIN	FUNCTION	PIN	FUNCTION
1	VCC	6	NC
2	AGND	7	GND
3	FIR_SEL	8	RXD
4	MD0	9	TXD
5	MD1	10	LEDA

LEGEND:
MC – MOUNTING CENTER
OC – OPTICAL CENTER

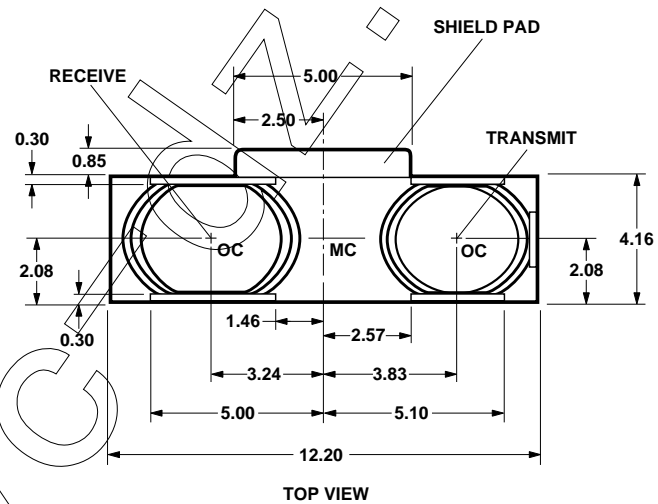
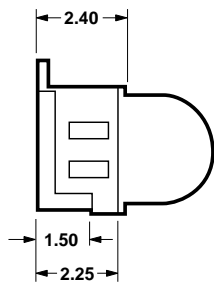
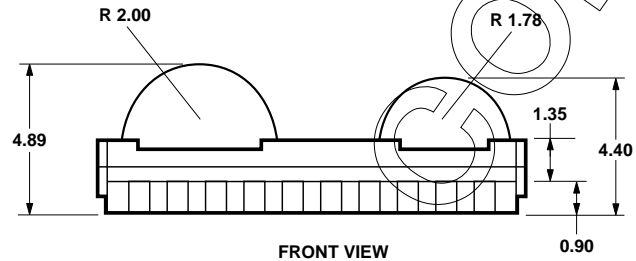

ALL DIMENSIONS IN MILLIMETERS (mm).
DIMENSION TOLERANCE IS 0.20 mm
UNLESS OTHERWISE SPECIFIED.

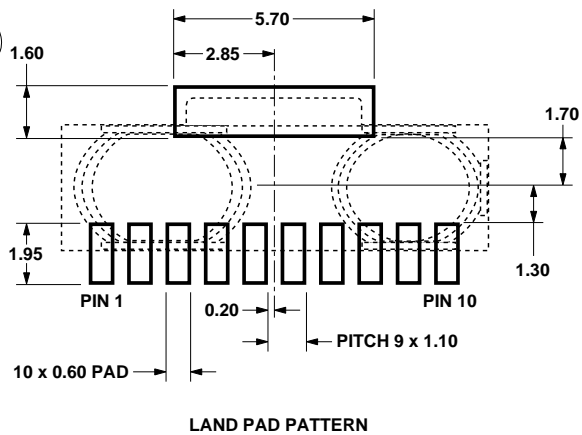
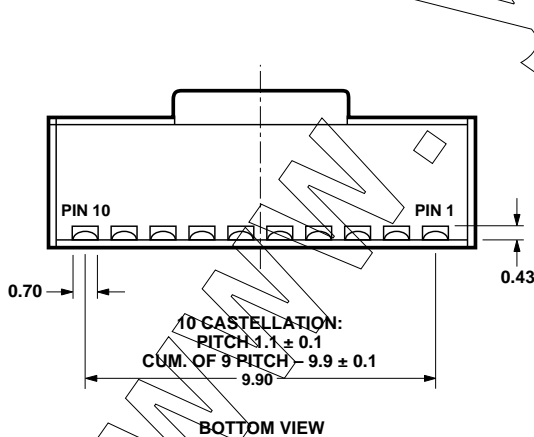

HSDL-3600#107 and HSDL-3600#117 Package Outline with Dimension and Recommended PC Board Pad Layout

HSDL-3600#107/#117
(Top Option)

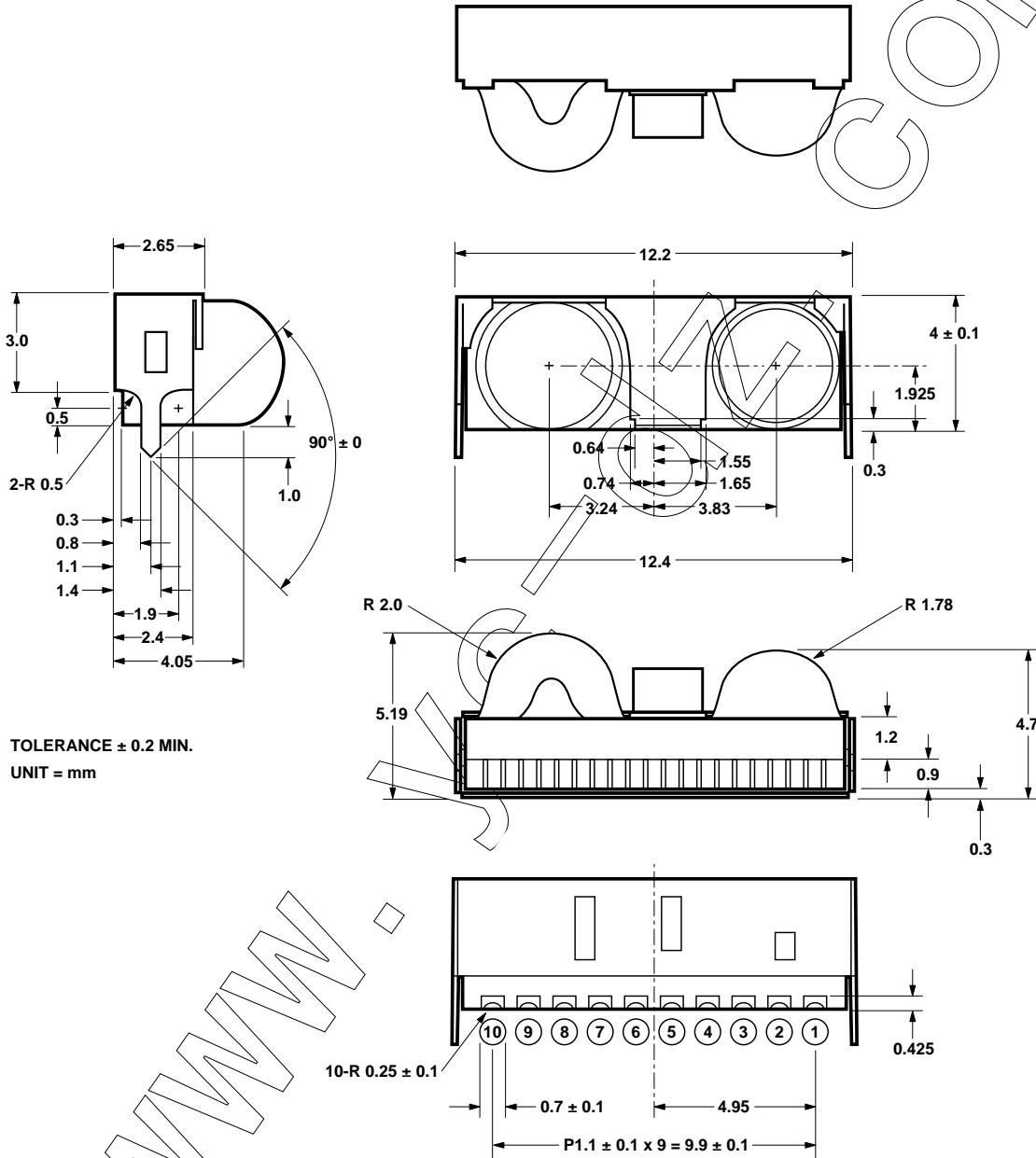

TOLERANCE ± 0.2 MIN.
UNIT = mm

- | | |
|-------------------|--------|
| ① V _{DD} | ⑥ N.C. |
| ② AGND | ⑦ GND |
| ③ FIREN | ⑧ RXD |
| ④ MD0 | ⑨ TXD |
| ⑤ MD1 | ⑩ LEDA |

Tape and Reel Dimensions (HSDL-3600#007, #017)

All dimensions in millimeters (mm)

Quantity = 400 pieces per reel (HSDL-3600#007)
 10 pieces per tape (HSDL-3600#017)

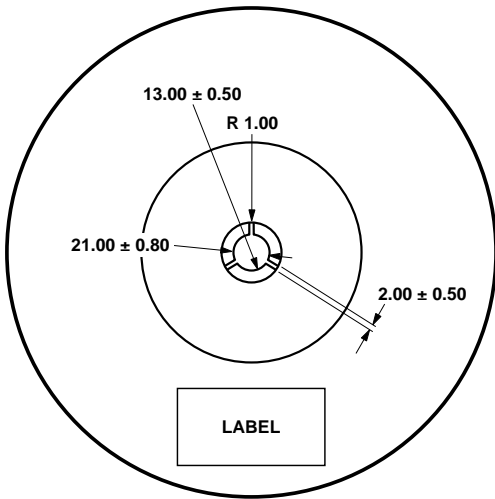

SHAPE AND DIMENSIONS OF REELS

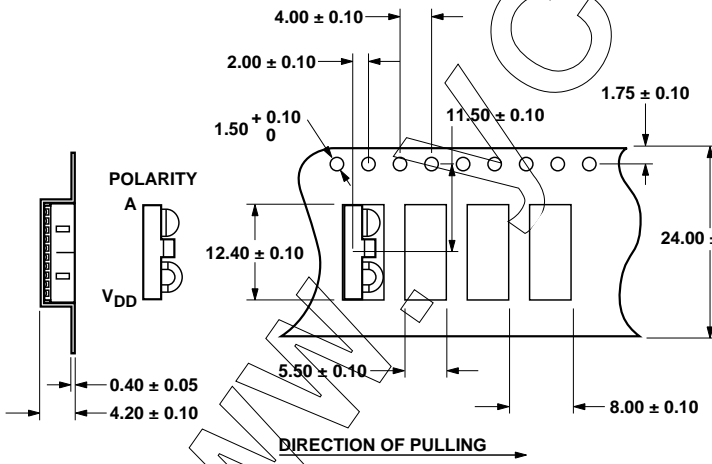
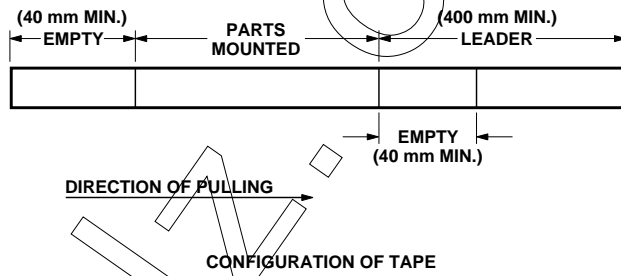

TAPE DIMENSIONS

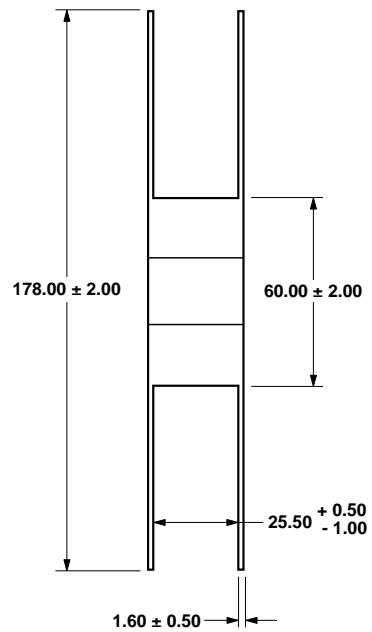

Tape and Reel Dimensions (HSDL-3600#008, #018)

All dimensions in millimeters (mm)

Quantity = 400 pieces per reel (HSDL-3600#008)
 10 pieces per tape (HSDL-3600#018)

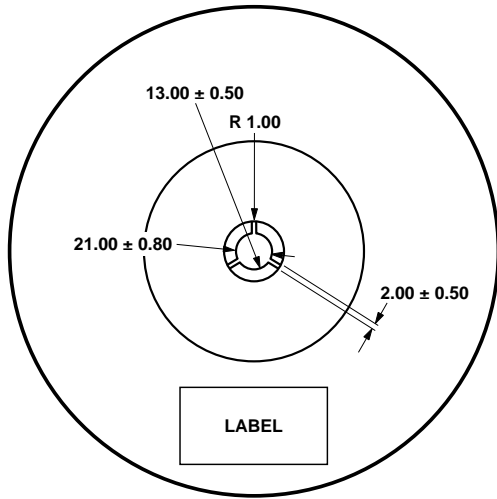

SHAPE AND DIMENSIONS OF REELS

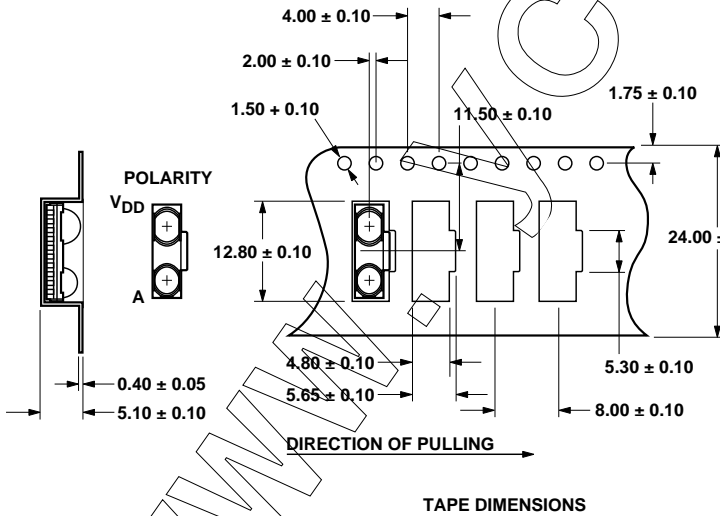
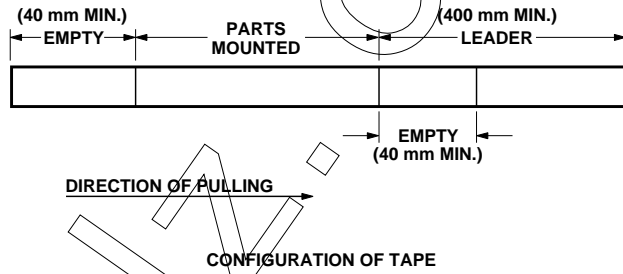

TAPE DIMENSIONS

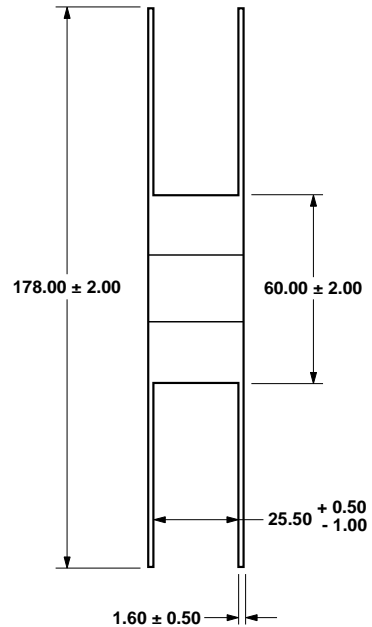

Tape and Reel Dimensions (HSDL-3600#107, #117)

All dimensions in millimeters (mm)

Quantity = 300 pieces per reel (HSDL-3600#107)
10 pieces per tape (HSDL-3600#117)

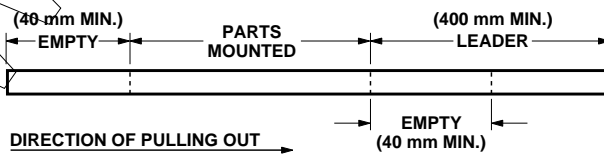
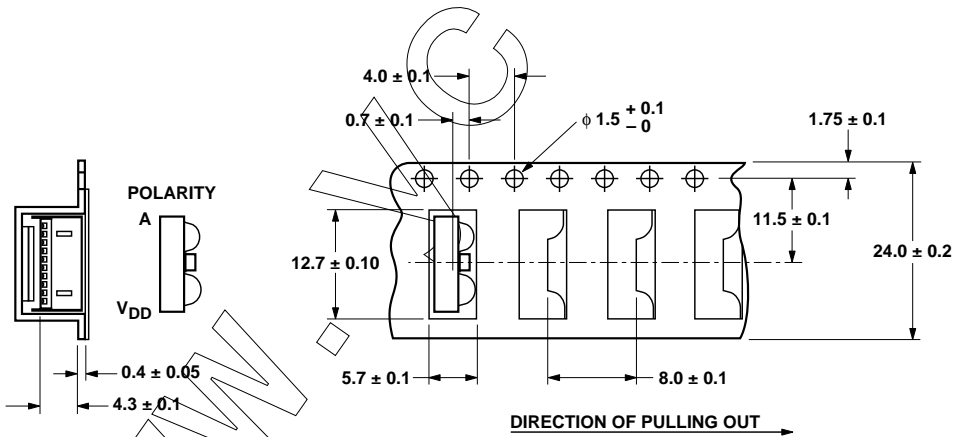
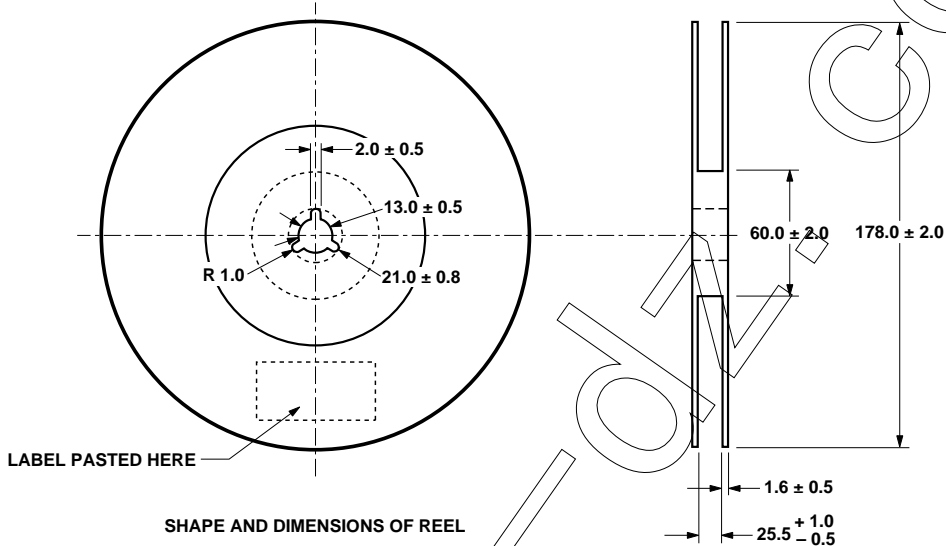

N = 300 PCS

Moisture Proof Packaging

All HSDL-3600 options are shipped in moisture proof package. Once opened, moisture absorption begins.

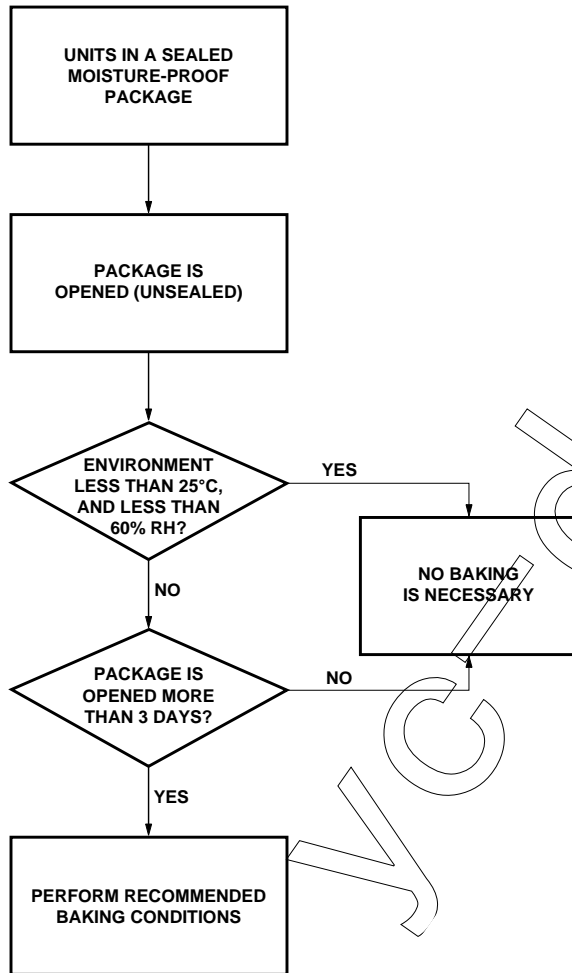

Baking Conditions

If the parts are not stored in dry conditions, they must be baked before reflow to prevent damage to the parts.

Package	Temperature	Time
In Reel	60°C	≥ 48 hours
In Bulk	100°C	≥ 4 hours
	125°C	≥ 2 hours

Baking should only be done once.

Reflow Profile

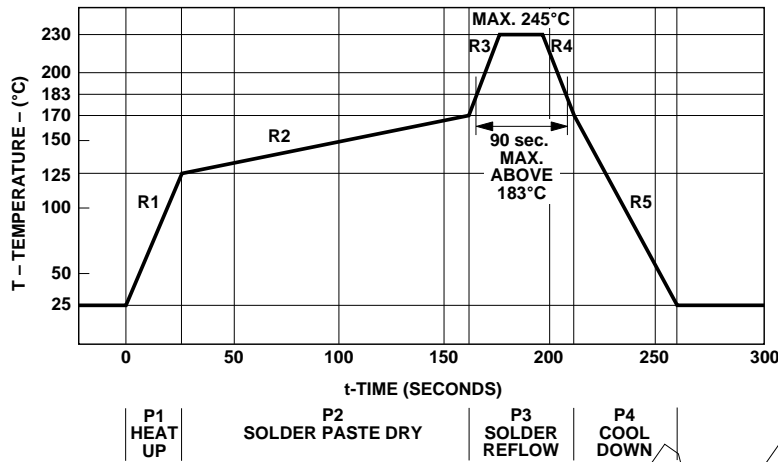

Process Zone	Symbol	ΔT	Maximum $\Delta T/\Delta \text{time}$
Heat Up	P1, R1	25°C to 125°C	4°C/s
Solder Paste Dry	P2, R2	125°C to 170°C	0.5°C/s
Solder Reflow	P3, R3	170°C to 230°C (245°C at 10 seconds max.)	4°C/s
	P3, R4	230°C to 170°C	-4°C/s
Cool Down	P4, R5	170°C to 25°C	-3°C/s

The reflow profile is a straight-line representation of a nominal temperature profile for a convective reflow solder process. The temperature profile is divided into four process zones, each with different $\Delta T/\Delta \text{time}$ temperature change rates. The $\Delta T/\Delta \text{time}$ rates are detailed in the above table. The temperatures are measured at the component to printed circuit board connections.

In **process zone P1**, the PC board and HSDL-3600 castellation I/O pins are heated to a temperature of 125°C to activate the flux in the solder paste. The temperature ramp up rate, R1, is limited to 4°C per second to allow for even heating of both the PC board and HSDL-3600 castellation I/O pins.

Process zone P2 should be of sufficient time duration (> 60 seconds) to dry the solder paste. The temperature is raised to a level just below the liquidus point of the solder, usually 170°C (338°F).

Process zone P3 is the solder reflow zone. In zone P3, the temperature is quickly raised above the liquidus point of solder to 230°C (446°F) for optimum results. The dwell time above the liquidus point of solder should be between 15 and 90 seconds. It usually takes about 15 seconds to assure proper coalescing of the solder balls into liquid solder and the formation of good solder connections. Beyond a dwell time of 90 seconds, the intermetallic growth within the solder connections becomes excessive,

resulting in the formation of weak and unreliable connections. The temperature is then rapidly reduced to a point below the solidus temperature of the solder, usually 170°C (338°F), to allow the solder within the connections to freeze solid.

Process zone P4 is the cool down after solder freeze. The cool down rate, R5, from the liquidus point of the solder to 25°C (77°F) should not exceed -3°C per second maximum. This limitation is necessary to allow the PC board and HSDL-3600 castellation I/O pins to change dimensions evenly, putting minimal stresses on the HSDL-3600 transceiver.

Appendix A: Test Method

A1. Background Light and Electromagnetic Field

There are four ambient interference conditions in which the receiver is to operate correctly. The conditions are to be applied separately:

1. Electromagnetic field:
3 V/m maximum (please refer to IEC 801-3, severity level 3 for details).

2. Sunlight:
10 kilolux maximum at the optical port. This is simulated with an IR source having a peak wavelength within the range of 850 nm to 900 nm and a spectral width of less than 50 nm biased to provide $490 \mu\text{W}/\text{cm}^2$ (with no modulation) at the optical port. The light source faces the optical port.

This simulates sunlight within the IrDA spectral range. The effect of longer wavelength radiation is covered by the incandescent condition.

3. Incandescent Lighting:
1000 lux maximum. This is produced with general service, tungsten-filament, gas-filled, inside frosted lamps in the 60 Watt to 100 Watt range to generate 1000 lux over the horizontal surface on which the equipment under test rests. The light sources are above the test area. The source is expected to have a filament temperature in the 2700 to 3050 Kelvin range and a spectral peak in the 850 to 1050 nm range.

4. Fluorescent Lighting:
1000 lux maximum. This is simulated with an IR source having a peak wavelength within the range of 850 nm to 900 nm and a spectral width of less than 50 nm biased and modulated to provide an optical square wave

signal ($0 \mu\text{W}/\text{cm}^2$ minimum and $0.3 \mu\text{W}/\text{cm}^2$ peak amplitude with 10% to 90% rise and fall times less than or equal to 100 ns) over the horizontal surface on which the equipment under test rests. The light sources are above the test area. The frequency of the optical signal is swept over the frequency range from 20 kHz to 200 kHz.

Due to the variety of fluorescent lamps and the range of IR emissions, this condition is not expected to cover all circumstances. It will provide a common floor for IrDA operation.

All Agilent IR transceivers operating under the recommended drive conditions are classified as CENELEC EN60825-1 Accessible Emission Limit (AEL) Class 1. This standard is in effect in Europe as of January 1, 1997. AEL Class 1 LED devices are considered eye safe. Please see Application Note 1094 for more information.

Appendix B : HSDL-3600#007/#017 SMT Assembly Application Note

1.0 Solder Pad, Mask and Metal Solder Stencil Aperture

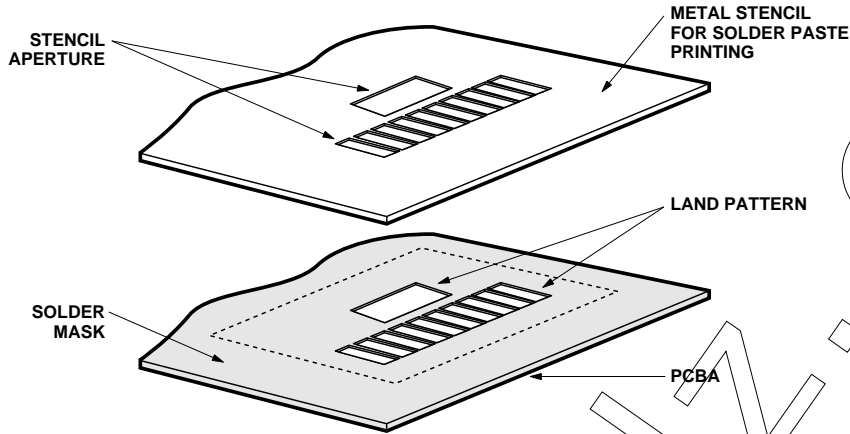

Figure 1.0. Stencil and PCBA.

1.1 Recommended Land Pattern for HSDL-3600#007/#017

Dim.	mm	Inches
a	2.40	0.095
b	0.70	0.028
c (pitch)	1.10	0.043
d	2.35	0.093
e	2.80	0.110
f	3.13	0.123
g	4.31	0.170

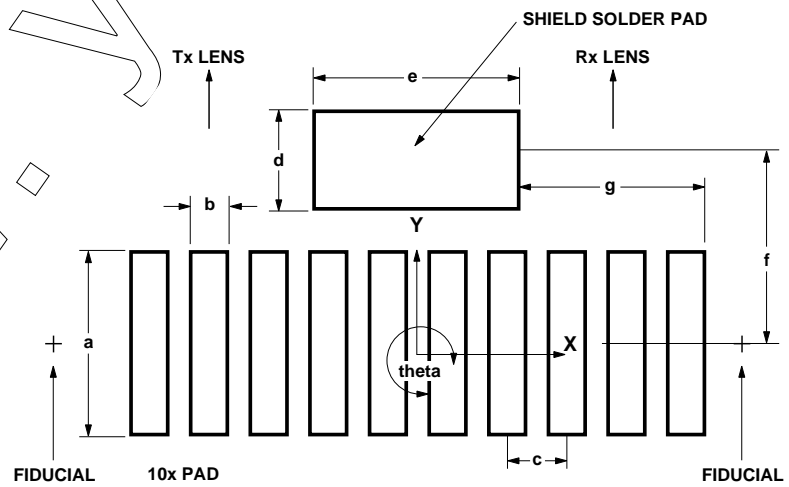

Figure 2.0. Top View of Land Pattern.

1.2 Adjacent Land Keep-out and Solder Mask Areas

Dim.	mm	Inches
h	min. 0.2	min. 0.008
j	13.4	0.528
k	4.7	0.185
l	3.2	0.126

- Adjacent land keep-out is the **maximum space** occupied by the unit relative to the land pattern. There should be no other SMD components within this area.
- “ h ” is the minimum solder resist strip width required to avoid solder bridging adjacent pads.
- It is recommended that 2 fiducial cross be placed at mid-length of the pads for unit alignment.

Note: Wet/Liquid Photo-Imaginable solder resist/mask is recommended.

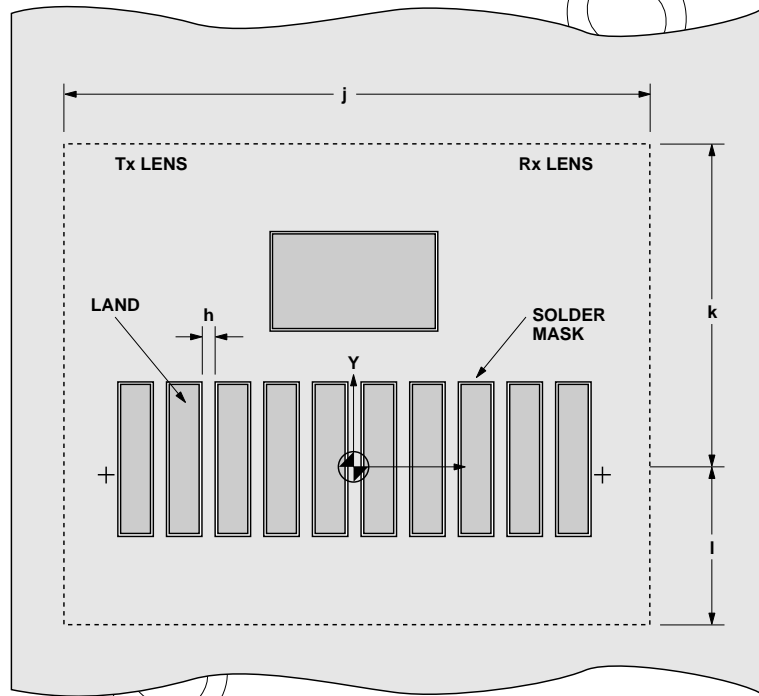

2.0 Recommended Solder Paste/cream Volume for Castellation Joints

Based on calculation and experiment, the printed solder paste volume required per castellation pad is **0.30 cubic mm** (based on either no-clean or aqueous solder cream types with typically 60 to 65% solid content by volume).

Figure 3-0. HSDL-3600#007/#017 PCBA – Adjacent Land Keep-out and Solder Mask.

2.1 Recommended Metal Solder Stencil Aperture

It is recommended that only 0.152 mm (0.006 inches) or 0.127 mm (0.005 inches) thick stencil be used for solder paste

printing. This is to ensure adequate printed solder paste volume and no shorting. The following combination of metal stencil aperture and metal stencil thickness should be used:

See Fig 4.0			
<i>t</i> , nominal stencil thickness		<i>l</i> , length of aperture	
mm	inches	mm	inches
0.152	0.006	2.8 ± 0.05	0.110 ± 0.002
0.127	0.005	3.4 ± 0.05	0.134 ± 0.002
<i>w</i> , the width of aperture is fixed at 0.70 mm (0.028 inches)			
Aperture opening for shield pad is 2.8 mm x 2.35 mm as per land dimensions			

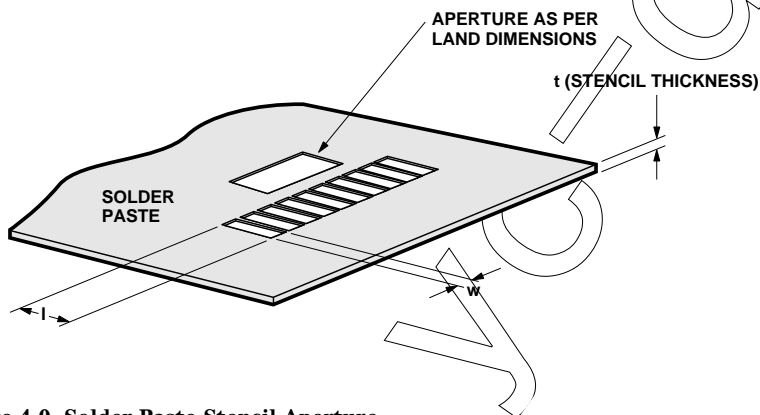

Figure 4.0 Solder Paste Stencil Aperture.

3.0 Pick and Place Misalignment Tolerance and Product Self-Alignment after Solder Reflow

If the printed solder paste volume is adequate, **the unit will self-align** in the X-direction after solder reflow. Units should be properly reflowed in IR Hot Air convection oven using the recommended reflow profile. The direction of board travel does not matter.

Allowable Misalignment Tolerance

X - direction	≤ 0.2 mm (0.008 inches)
Theta - direction	+/- 2 degrees

3.1 Tolerance for X-axis Alignment of Castellation

Misalignment of castellation to the land pad should not exceed 0.2 mm or approximately half the width of the castellation during

placement of the unit. The castellations will completely self-align to the pads during solder reflow as seen in the pictures below.



Photo 1.0. Castellation misaligned to land pads in x-axis before reflow.

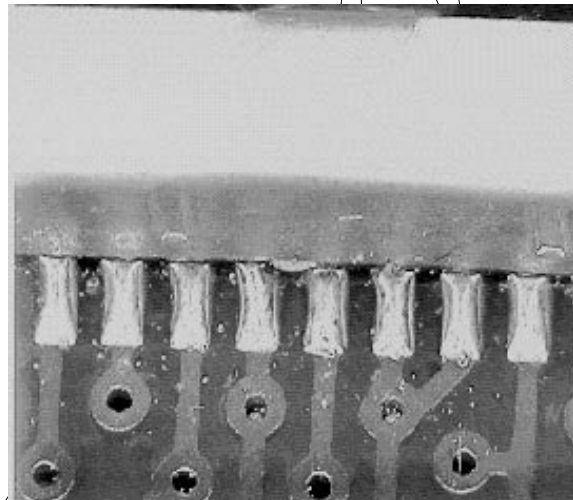

Photo 2.0. Castellation self-align to land pads after reflow.

3.2 Tolerance for Rotational (Theta) Misalignment

Units when mounted should not be rotated more than ± 2 degrees with reference to center X-Y as specified in Fig 2.0. Pictures 3.0 and 4.0 show units before and

after reflow. Units with a Theta misalignment of more than 2 degrees do not completely self-align after reflow. Units with ± 2 degree rotational or Theta misalignment self-aligned completely after solder reflow.

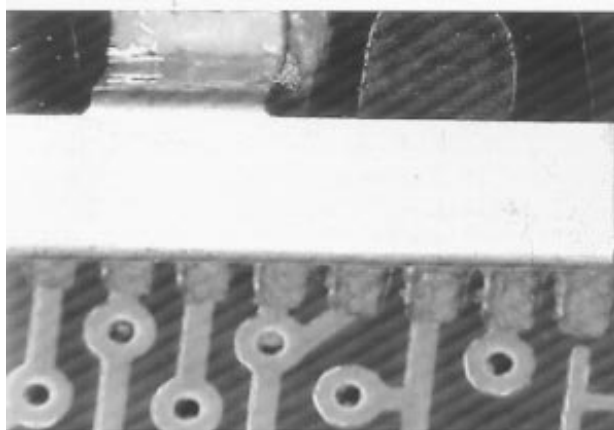

Photo 3.0. Unit is rotated before reflow.



Photo 4.0. Unit self-aligns after reflow.

3.3 Y-axis Misalignment of Castellation

In the Y-direction, the unit does not self-align after solder reflow. It is recommended that the unit be placed in line with the fiducial

mark (mid-length of land pad.) This will enable sufficient land length (minimum of 1/2 land length.) to form a good joint. See Fig 5.0.

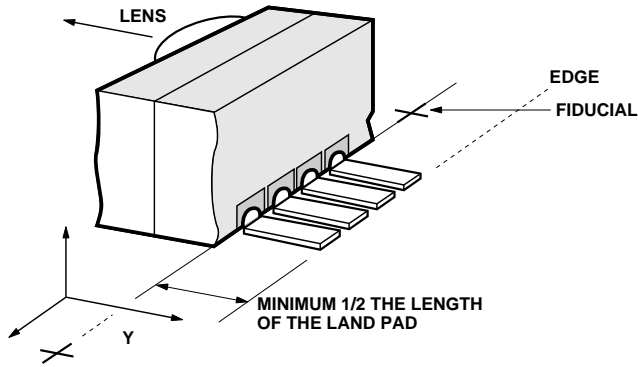

Figure 5.0. Section of a Castellation in Y-axis.

3.4 Example of Good HSDL-3600#007/#017 Castellation Solder Joints

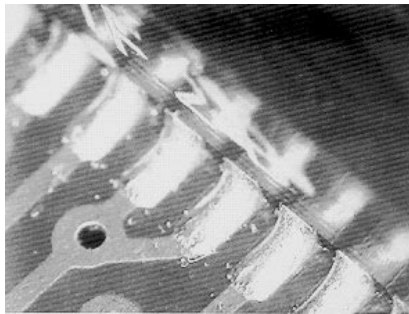
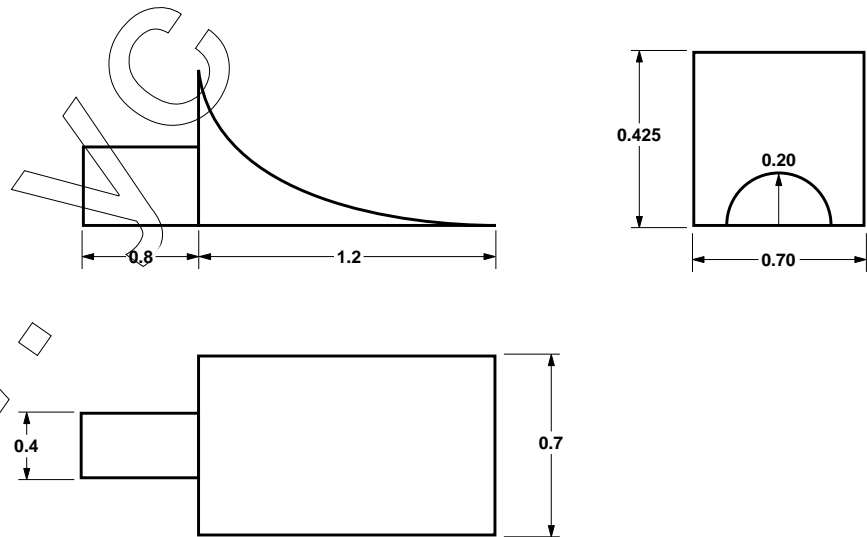

Photo 5.0. Good Solder Joint.

This joint is formed when the printed solder paste volume is adequate, i.e. 0.30 cubic mm and reflowed properly. It should be reflowed in IR Hot-air convection reflow oven. Direction of board travel does not matter.

4.0 Solder Volume Evaluation and Calculation

Geometry of an HSDL-3600#007/#017 solder fillet.



Appendix C: HSDL-3600#008/#018 SMT Assembly Application Note

1.0 Solder Pad, Mask and Metal Solder Stencil Aperture

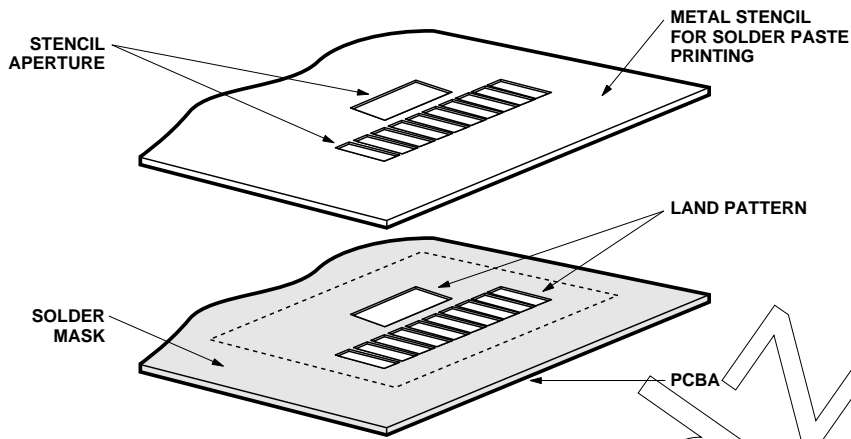

Figure 1.0. Stencil and PCBA.

1.1 Recommended Land Pattern for HSDL-3600#008/#018

Dim.	mm	Inches
a	1.95	0.077
b	0.60	0.024
c (pitch)	1.10	0.043
d	1.60	0.063
e	5.70	0.224
f	3.80	0.150
g	2.40	0.094
h	0.80	0.032

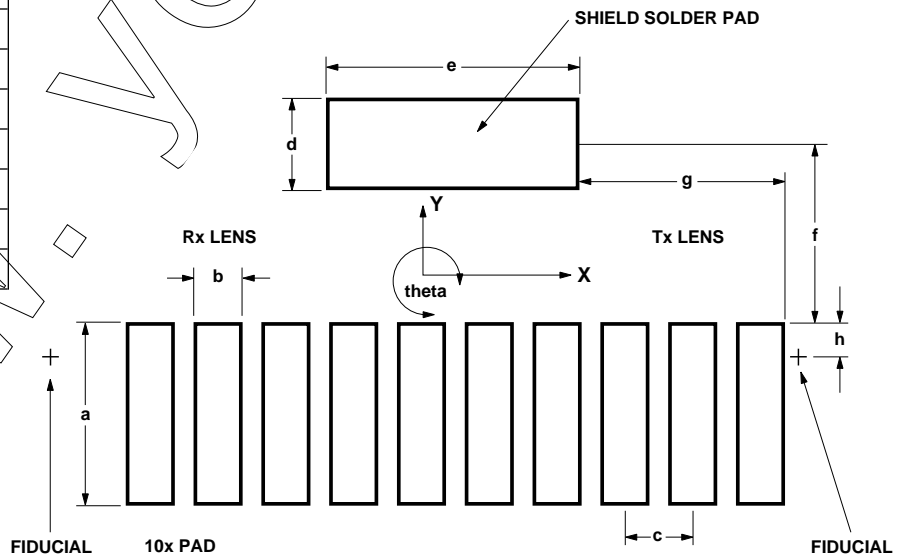

Figure 2.0. Top View of Land Pattern.

1.2 Adjacent Land Keep-out and Solder Mask Areas

Dim.	mm	Inches
<i>h</i>	min. 0.2	min. 0.008
<i>j</i>	13.4	0.528
<i>k</i>	5.8	0.228
<i>l</i>	3.5	0.130

- Adjacent land keep-out is the **maximum space** occupied by the unit relative to the land pattern. There should be no other SMD components within this area.
- “**h**” is the minimum solder resist strip width required to avoid solder bridging adjacent pads.
- It is recommended that 2 fiducial cross be placed at mid-length of the pads for unit alignment.

Note: Wet/Liquid Photo-Imaginable solder resist/mask is recommended.

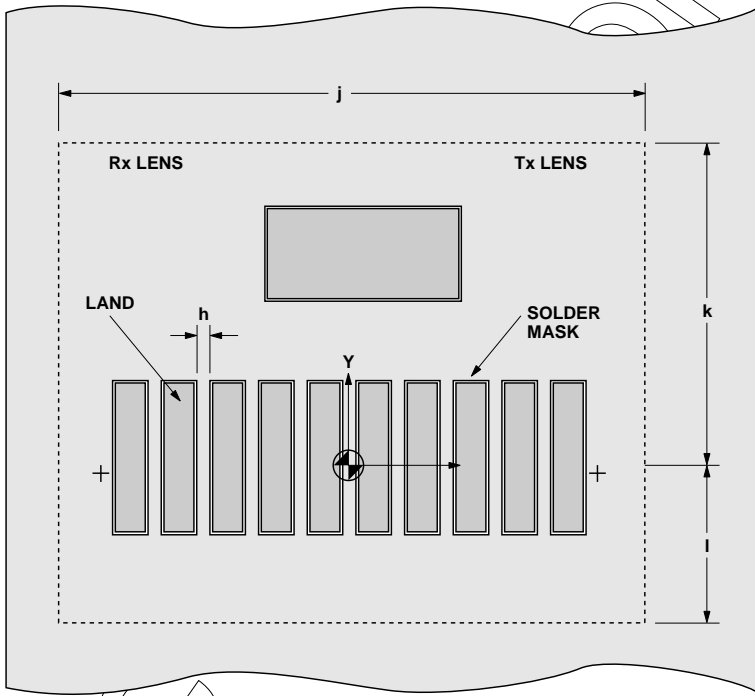

Figure 3.0. HSDL-3600#008/#018 PCBA – Adjacent Land Keep-out and Solder Mask.

2.0 Recommended Solder Paste/cream Volume for Castellation Joints

Based on calculation and experiment, the printed solder paste volume required per castellation pad is **0.28 cubic mm** (based on either no-clean or aqueous solder cream types with typically 60 to 65% solid content by volume).

2.1 Recommended Metal Solder Stencil Aperture

It is recommended that only 0.152 mm (0.006 inches) or 0.127 mm (0.005 inches) thick stencil be used for solder paste

printing. This is to ensure adequate printed solder paste volume and no shorting. The following combination of metal stencil aperture and metal stencil thickness should be used:

See Fig 4.0			
<i>t</i> , nominal stencil thickness		<i>l</i> , length of aperture	
mm	inches	mm	inches
0.152	0.006	3.1 ± 0.05	0.122 ± 0.002
0.127	0.005	3.7 ± 0.05	0.147 ± 0.002
<i>w</i> , the width of aperture is fixed at 0.60 mm (0.024 inches)			
Aperture opening for shield pad is 5.7 mm x 1.6 mm as per land dimensions			

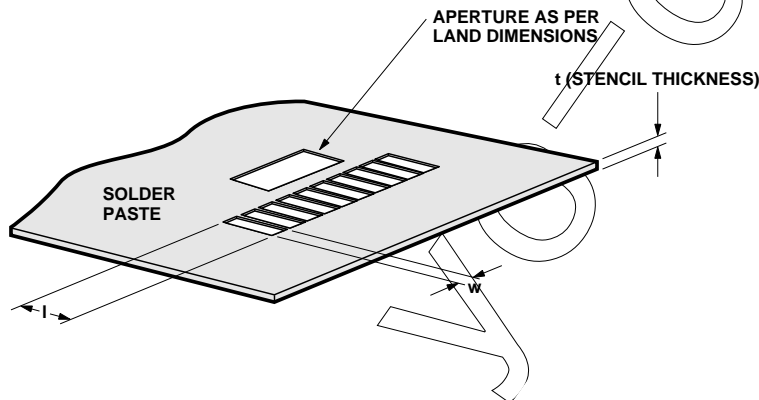

Figure 4.0. Solder Paste Stencil Aperture.

3.0 Pick and Place Misalignment Tolerance and Product Self-Alignment after Solder Reflow

If the printed solder paste volume is adequate, **the unit will self-align** in X-direction after solder reflow. Units should be properly reflowed in IR Hot Air convection oven using the recommended reflow profile. The direction of board travel does not matter.

Allowable Misalignment Tolerance

X - direction	$\leq 0.2 \text{ mm (0.008 inches)}$
----------------------	--------------------------------------

3.1 Tolerance for X-axis Alignment of Castellations

Misalignment of castellation to the land pad should not exceed 0.2 mm or approximately half the width of the castellation during

placement of the unit. The castellations will completely self-align to the pads during solder reflow as seen in the pictures below.

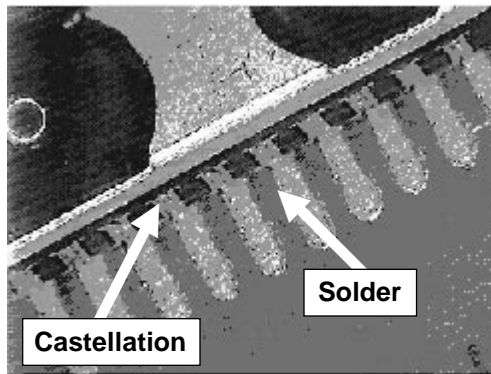

Photo 1.0. Castellation mis-aligned to land pads in X-axis before reflow.

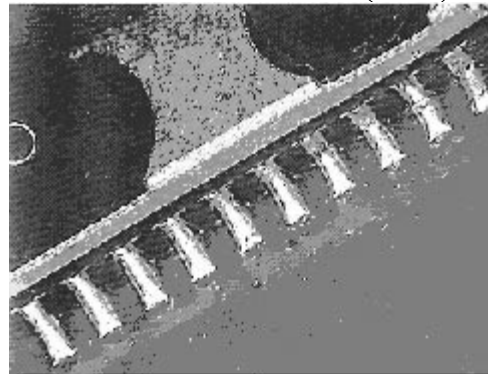

Photo 2.0. Castellation self-aligned to land pads after reflow.

3.2 Tolerance for Rotational (Theta) Misalignment

Units when mounted should not be rotated more than ± 1 degrees with reference to center X-Y as specified in Fig. 2.0. Photos 3.0

and 4.0 show that unit cannot be self-aligned back due to the small wetting force. Units with a Theta misalignment of more than 1 degree do not completely self-align after reflow.

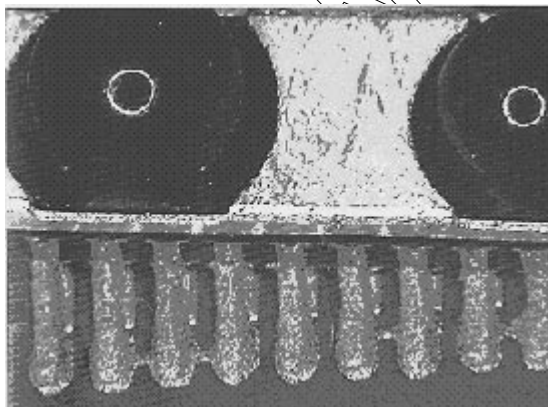

Photo 3.0. Unit is rotated before reflow.

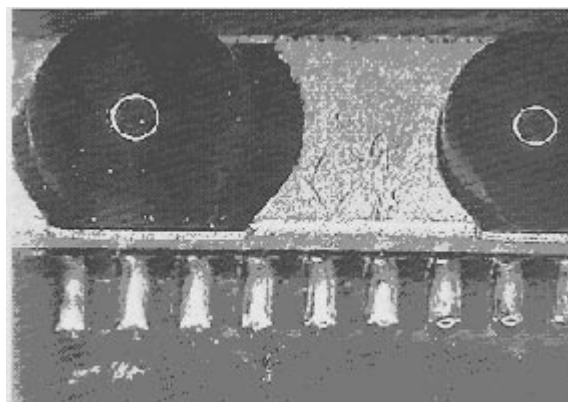

Photo 4.0. Unit not self-aligned after reflow.

3.3 Y-axis Misalignment of Castellations

In the Y-direction, the unit does not self align after solder reflow. It is recommended that the unit

be placed in line with the fiducial mark. This will enable sufficient land length to form a good joint. See Fig. 5.0.

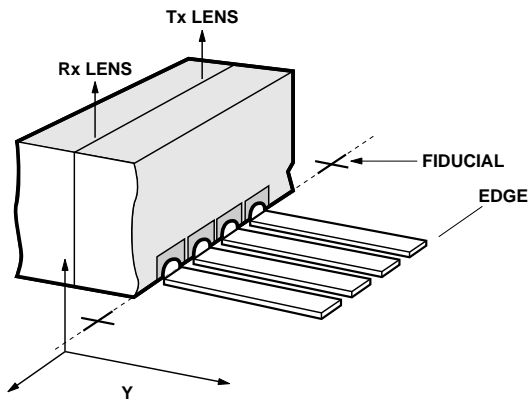

Figure 5.0. Section of a Castellations in Y-axis.

3.4 Example of Good Castellations Solder Joints

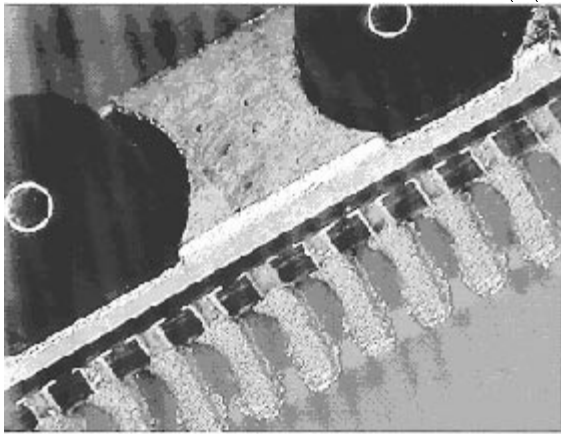

Photo 6.0. Good Attachment before Reflow.

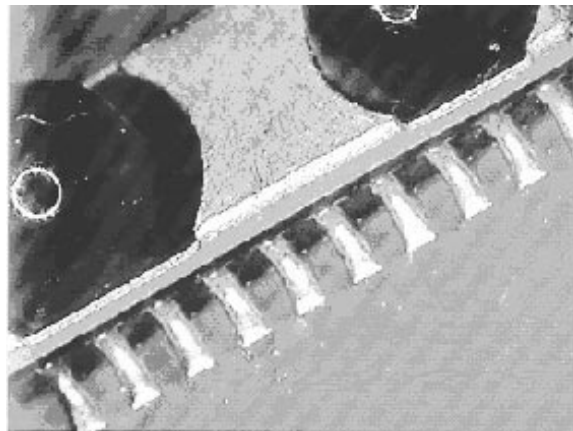

Photo 7.0. Good Solder Joint after Reflow.

This joint is formed when the printed solder paste volume is adequate, i.e. 0.30 cubic mm and reflowed properly. It should be

reflowed in IR Hot-air convection reflow oven. Direction of board travel does not matter.

4.0 Solder Volume Evaluation and Calculation

Geometry of an HSDL-3600#008/#018 solder fillet.

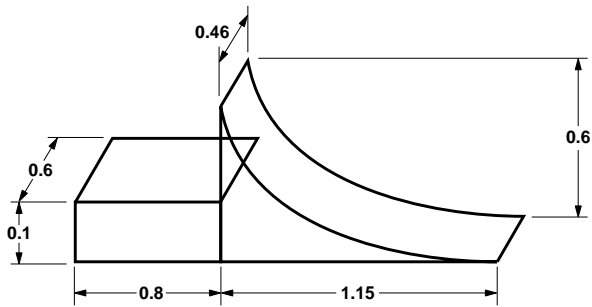

$$V_{\text{solder}} = (0.8 \times 0.6 \times 0.1) + (0.5 \times 0.6 \times 0.46 (0.6 + 1.15)/2) = 0.1662 \text{ mm}^3$$

$$V_{\text{paste}} = V_{\text{solder}}/0.6 = 0.277 \text{ mm}^3$$

Appendix D: General Application Guide for the HSDL-3600 Infrared IrDA® Compliant 4 Mb/s Transceiver

Description The HSDL-3600 wide voltage operating range infrared transceiver is a low-cost and small form factor that is designed to address the mobile computing market such as notebooks, printers and LAN access as well as small embedded mobile products such as digital cameras, cellular phones, and PDAs. It is fully compliant to IrDA 1.1 specification up to 4 Mb/s, and supports HP-SIR, Sharp ASK, and TV Remote modes. The design of the HSDL-3600 also includes the following unique features:

- Low passive component count.
- Adjustable Optical Power Management (full, $2/3$, $1/3$ power).
- Shutdown mode for low power consumption requirement.
- Single-receive output for all data rates.

Adjustable Optical Power Management The HSDL-3600 transmitter offers user-adjustable optical power levels. The use of two logic-level mode-select input pins, MODE 0 and MODE 1, offers shutdown mode as well as three transmit power levels as shown in the Table below. The power levels are setup to correspond nominally to maximum, two-third, and one-third of the transmission distance. This unique feature allows lower optical power to be transmitted at shorter link distances to reduce power consumption.

MODE	MODE 1	Transmitter
1	0	Shutdown
0	0	Full Power
0	1	$2/3$ Power
1	1	$1/3$ Power

There are 2 basic means to adjust the optical power of the HSDL-3600:

Dynamic: This implementation enables the transceiver pair to adjust their transmitter power according to the link distance. However, this requires the IrDA protocol stack (mainly the IrLAP layer) to be modified. Please contact Hewlett Packard Application group for further details.

Static: Pre-program the ROM BIOS of the system (e.g. notebook PC, digital camera, cell phones, or PDA) to allow the end user to select the desired optical power during the system setup stage.

Selection of Resistor R1

Resistor R1 should be selected to provide the appropriate peak pulse LED current over different ranges of V_{cc} . The recommended R1 for the voltage range of 2.7 V to 3.3 V is 2.2 Ω while for 3.0 V to 3.6 V is 2.7 Ω . The HSDL-3600 typically provides

250 mW/sr of intensity at the recommended minimum peak pulse LED current of 400 mA.

Interface to Recommended I/O Chips The HSDL-3600's TXD data input is buffered to allow for CMOS drive levels. No peaking circuit or capacitor is required.

Data rate from 9.6 kb/s up to 4 Mb/s is available at the RXD pin. The FIR_SEL pin selects the data rate that is receivable through RXD. Data rates up to 115.2 kb/s can be received if FIR_SEL is set to logic low. Data rates up to 4 Mb/s can be received if FIR_SEL is set to logic high. Software driver is necessary to program the FIR_SEL to low or high at a given data rate.

4 Mb/s IR link distance of greater than 1.5 meters have been demonstrated using typical HSDL-3600 units with National Semiconductor's PC87109 3 V Endec and Super I/Os, and the SMC Super I/O chips.

(A) National Semiconductor Super I/O and Infrared Controller

For National Semiconductor Super I/O and Infrared Controller chips, IR link can be realized with the following connections:

- Connect IRTX of the National Super I/O or IR Controller to TXD (pin 9) of the HSDL-3600.
- Connect IRRX1 of the National Super I/O or IR Controller to RXD (pin 8) of the HSDL-3600.
- Connect IRSLO of the National Super I/O or IR Controller to FIR_SEL (pin 3) of the HSDL-3600.

Please refer to the table below for the IR pin assignments for the National Super I/O and IR Controllers that support IrDA 1.1 up to 4 Mb/s:

	IRTX	IRRX1	IRSLO
PC97/87338VJG	63	65	66
PC87308VUL	81	80	79
PC87108AVHG	39	38	37
PC87109VBE	15	16	14

Please refer to the National Semiconductor data sheets and application notes for updated information.

Functional Block Diagram

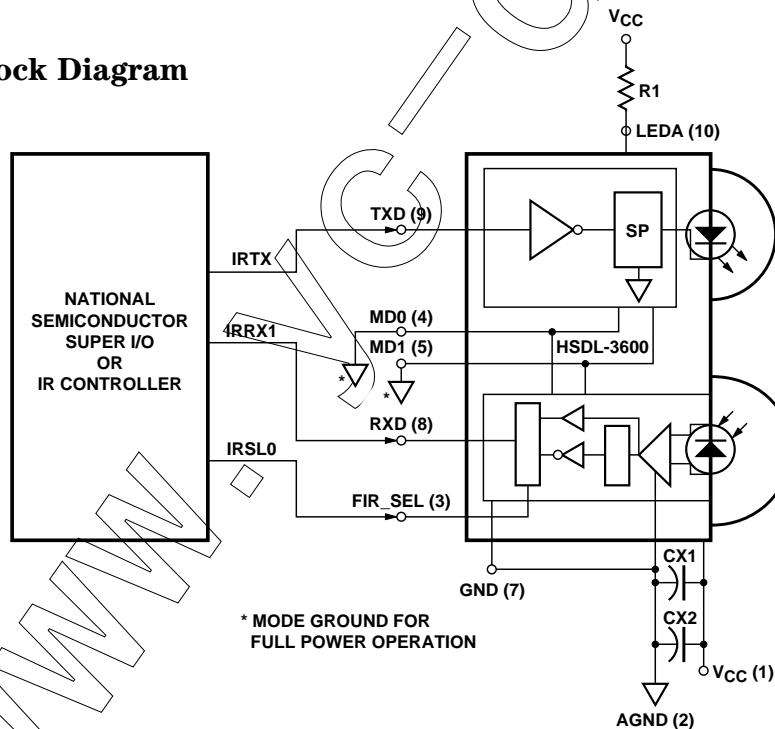

(B) HSDL-3600 Interoperability with National Semiconductor PC97338VJG SIO Evaluation Report

Introduction

The objective of this report is to demonstrate the interoperability of the HSDL-3600 IR transceiver IR module as wireless communication ports at the speed of 2.4 kb/s - 4 Mb/s with NS's PC97338VJG Super I/O under typical operating conditions.

Test Procedures

1. Two PC97338VJG evaluation boards were connected to the ISA Bus of two PCs (Pentium 200 MHz) running Microsoft's DOS operating system. One system with an HSDL-3600 IR

transceiver connected to the PC97338VJG evaluation board will act as the master device. Another system with an HSDL-3600 IR transceiver connected to the PC97338VJG will act as the slave device (i.e. Device Under Test).

2. The test software used in this interoperability test is provided by National Semiconductor. A file size of 1.7M byte from the master device, with the PC97338VJG performing the framing, encoding is transmitted to the slave device. The slave device, with the PC97338VJG performing the decoding, and

CRC checksum, will receive the file. The file is then checked for error by comparing the received file with the original file using the DOS "fc" command.

3. The link distance is measured by adjusting the distance between the master and slave for errorless data communications.

Functional Block Diagram

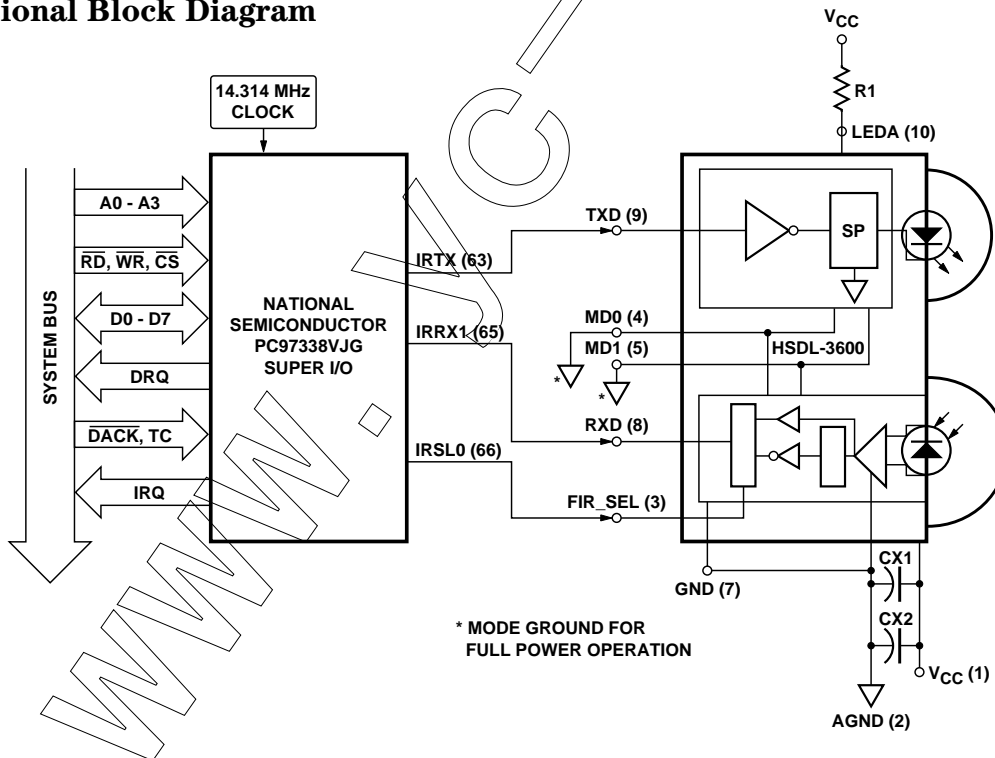

HSDL-3600 Interoperability with NS PC97338 Report

(i) Test Conditions

$V_{CC} = 3.0 - 3.6 \text{ V}$

$R_{LED} = 2.7 \Omega$

Optical transmitter pulse
width = 125 ns

Mode set to full power

(ii) Test Result

The interoperability test results show that HSDL-3600 IR transceiver can operate ≥ 1.5 meter link distance from 3 V to 3.6 V with NS's PC97338 at any IrDA 1.1 data rate without error.

(C) Standard Micro System Corporation (SMC) Super and Ultra I/O Controllers

For SMC Super and Ultra I/O Controller chips, IR link can be realized with the following connections:

- Connect IRTX of the SMC Super or Ultra I/O Controller to TXD (pin 9) of the HSDL-3600.
- Connect IRRX of the SMC Super or Ultra I/O Controller to RXD (pin 8) of the HSDL-3600.
- Connect IRMODE of the Super or Ultra I/O Controller to FIR_SEL (pin 3) of the HSDL-3600.

Please refer to the table below for the IR pin assignments for the SMC Super or Ultra I/O Controllers that support IrDA 1.1 up to 4Mb/s:

	IRTX	IRRX	IRMODE
FDC37C669FR	89	88	23
FDC37N769	87	86	21
FDC37C957/8FR	204	203	145 or 190

HSDL-3600 Interoperability with SMC 669/769 Report

(i) Test Conditions

$V_{CC} = 3.0 - 3.6 \text{ V}$

$R_{LED} = 2.7 \Omega$

Optical transmitter pulse
width = 125 ns

Mode set to full power

(ii) Test Result

The interoperability test results show that HSDL-3600 IR transceiver can operate ≥ 1.5 meter link distance from 3 V to 3.6 V with SMC 669/769 at any IrDA 1.1 data rate without error.

HSDL-3600 Interoperability with SMC's Super I/O or IR Controller

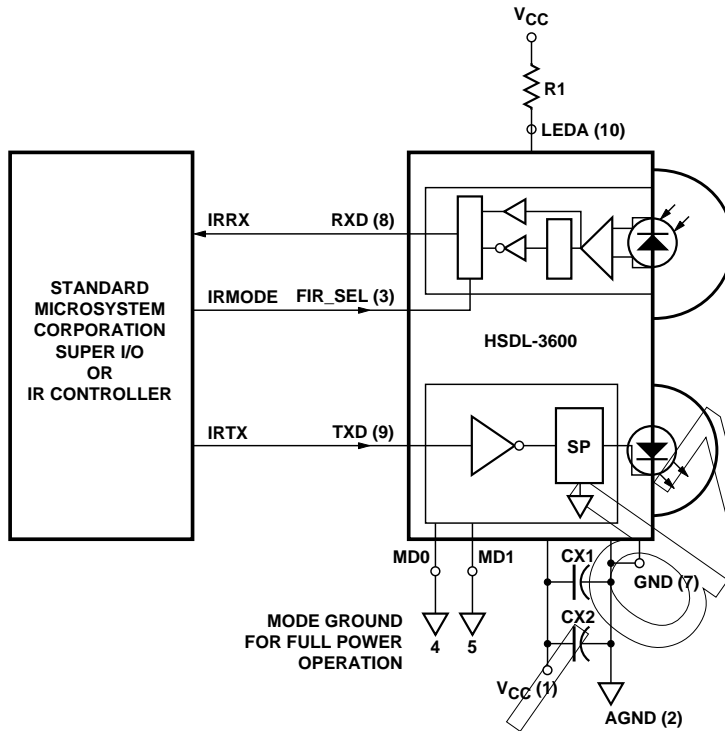

www.jc-dz.com

www.semiconductor.agilent.com

Data subject to change.
Copyright © 2001 Agilent Technologies Inc.
March 13, 2001
Obsoletes 5980-0460E (4/00)
5988-2311EN