

EW-450, EW-550

UNIPOLAR HALL EFFECT SWITCHES

Note : It is requested to read and accept "IMPORTANT NOTICE" written on the back of the front cover of this catalogue.

ASAHI HALL EFFECT ICs

ASAHI KASEI ELECTRONICS Hall Effect ICs are composed of a Ultra-high sensitive InSb Hall element and a signal processing IC chip in a package. ASAHI KASEI ELECTRONICS Hall Effect ICs have high sensitivity and good stability.

FEATURES

- Bop(max):20mT
- Effective Performance at Low Magnetic Field
- 4.5V to 18V Operation
- Highly Resistant to Mechanical Stress
- Stable Operation in Broad Temperature Range
- Compact Size
- Open Collector

APPLICATIONS

- Rotor Position Sensor for Precision Motors.
- Stroke Sensor
- Proximity Switch
- Encoder
- Current Switch etc.

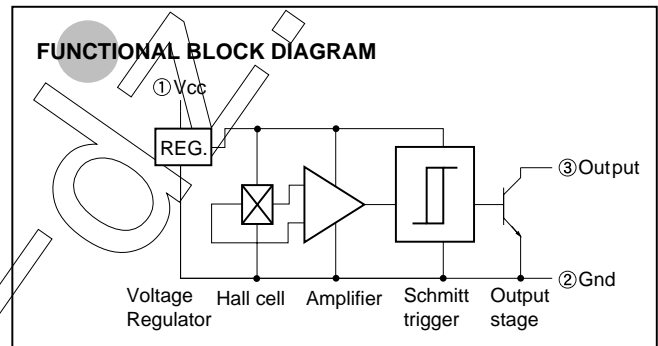
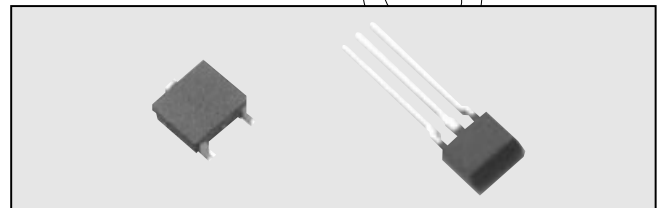

ABSOLUTE MAXIMUM RATINGS(Ta = 25)

Item	Symbol	Limit	Unit
Supply Voltage * 1	Vcc	18	V
Output "OFF" Voltage	Vo(off)	18	V
Output "ON" Current	I sink	15	mA
Operating Temperature Range	Topr	- 20 ~ + 115	
Storage Temperature Range	Tstg	- 40 ~ + 125	

* 1:Please refer to(Fig.1) DERATING CURVE

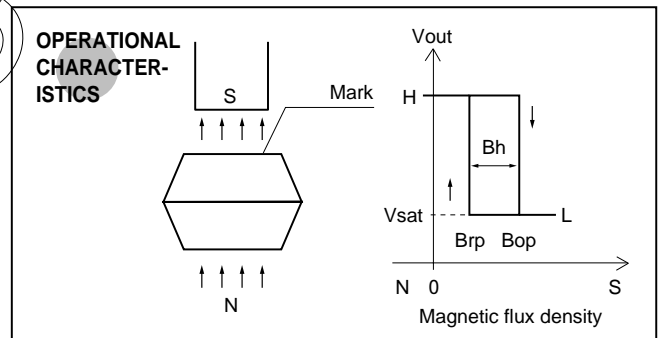

ELECTRICAL CHARACTERISTICS(Ta = 25 , Vcc = 4.5 ~ 18V DC.)

Item	Symbol	Conditions	Min.	Typ.	Max.	Unit
Operate Point	Bop	Vcc=12V			20	mT
Release Point	Brp	Vcc=12V	5			mT
Hysteresis	Bh		1.5			mT
Output Saturation Voltage	Vsat	Output"L", I sink=10mA			0.4	V
Supply Current	I cc	Output"H", Vcc=12V			8	mA
Output Leakage Current	I leak	Output"H", Vo=12V			1	μA

1mT = 10Gauss

Please be aware that AKE products are not intended for use in life support appliances, devices, or systems. Use of AKE products in such applications requires the written approval of the appropriate AKE officer. Certain applications using semiconductor devices may involve potential risks of personal injury, property damage, or loss of life. In order to minimize these risks, adequate design and operating safeguards should be provided by the customer to minimize inherent or procedural hazards. Inclusion of AKE products in such applications is understood to be fully at the risk of the customer using AKE devices or systems.

SUPPLY VOLTAGE DERATING CURVE

(Fig. 1)

EW-550

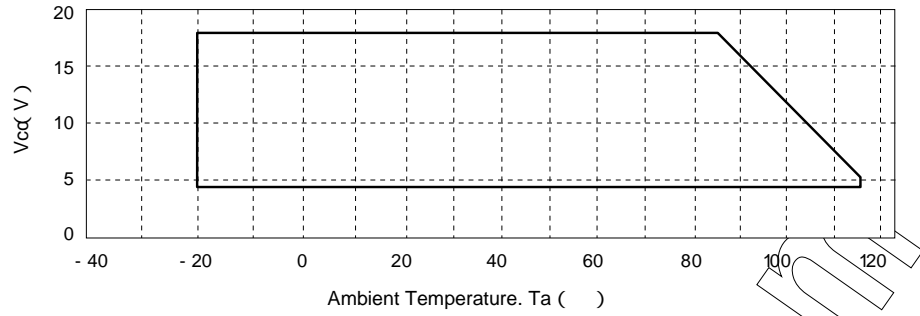

EW-450

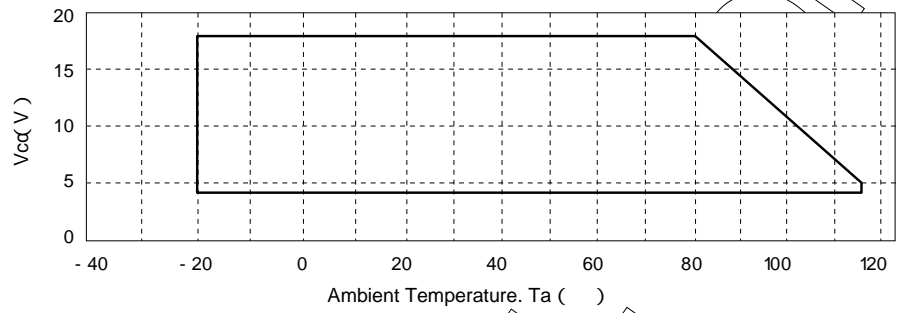

MARK AND SUPPLY STYLE

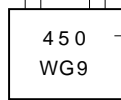
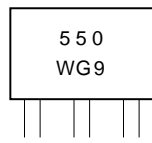

TYPE NO.

Supplied by
EW-550:500pcs. / Pack.
EW-450:5000pcs. / Reel

PACKAGE [Unit : mm]

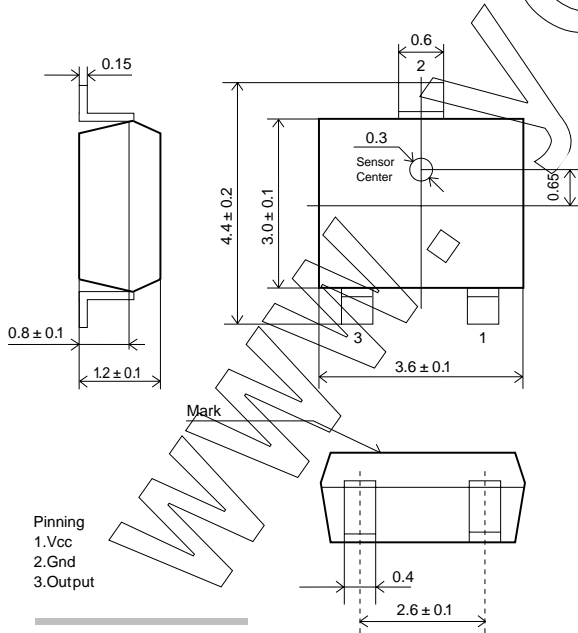

Pinning
1.Vcc
2.Gnd
3.Output

EW-450(453, 454)

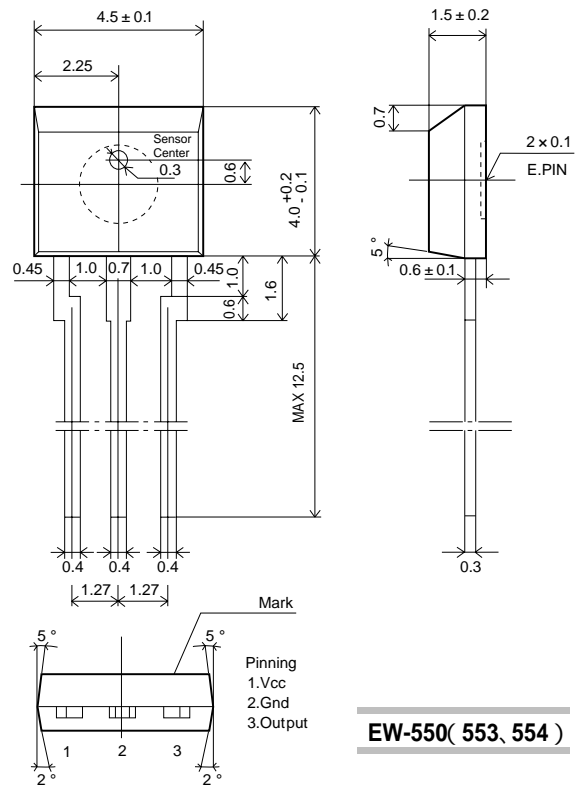

Pinning
1.Vcc
2.Gnd
3.Output

EW-550(553, 554)