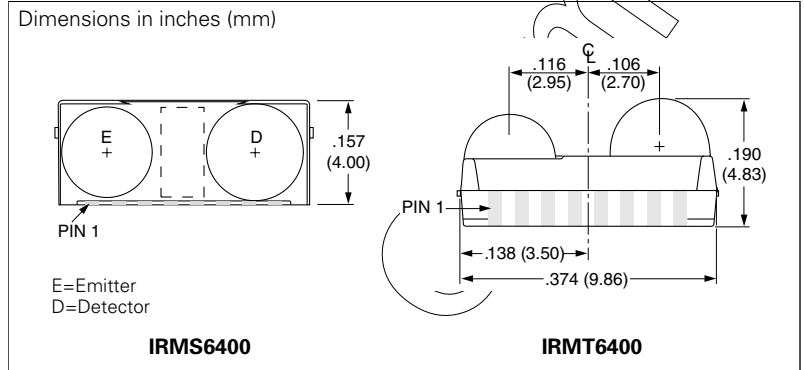




# SIDE VIEW IRMS6400/TOP VIEW IRMT6400

## 4 Mb/s Infrared Data Transceiver



### FEATURES

- Compliant with IrDA Specification
- Data Rates 9.6 Kb/s to 4.0 Mb/s
- Wide Range of Supply Voltage 2.6 to 5.5 V
- Standby Current 3.3 mA at 5.0 V Typical
- Shut Down Current 0.01  $\mu$ A Typical
- Excellent Power Supply Noise Rejection
- Tri-State Receiver Output and TxD Disable
- AC Coupled Transmit Input
  - Provides Integrated Protection for Eye Safety
- High DC Ambient Rejection
- Independent LED Supply, Anode Pin Can Take
  - up to 9.0 V DC when not transmitting and
  - up to 4.0 V above  $V_{CC}$  when Transmitting
- Receiver Latency Less than 100  $\mu$ s
- Slimline Package:
  - H 4.0 mm x D 4.8 mm x L 9.8 mm

### DESCRIPTION

With state of the art submicron BiCMOS circuitry, coupled with Vishay optoelectronic expertise, the IRMS6400/IRMT6400 outperforms its closest rival. Vishay has incorporated a mode selection pin that toggles the device to operate in FIR (4 Mb/s) or SIR/MIR (9.6 Kb/s to 1.152 Mb/s) mode. Its external Shut Down (SD) feature cuts current consumption to typically 0.01  $\mu$ A. The transmit input is AC coupled, limiting transmit pulse duration to 70  $\mu$ s, preventing transmitter damage and continuous LED output. Mode select determines the data rate. Low for 9.6 Kb/s to 1.152 Mb/s, high for 4 Mb/s.

### Absolute Maximum Ratings, $T_A = 25^\circ\text{C}$ (except where noted)

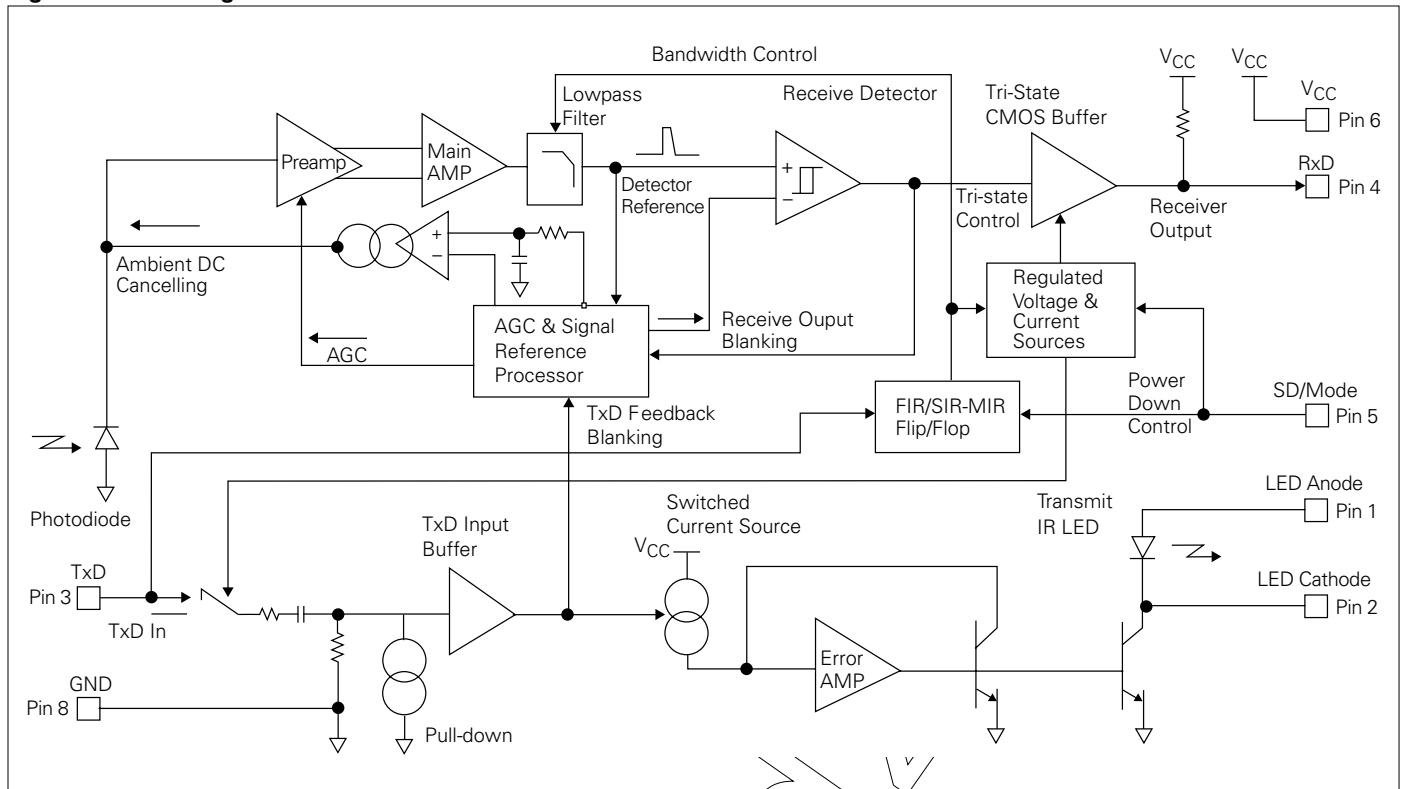
Supply Voltage Range, all states, $V_{CC}$	-0.5 to +7.0 V
LED Anode Voltage, not transmitting, $V_{LEDA}$	9.0 V
LED Anode Voltage, transmitting, $V_{LEDA}$	$4.0\text{ V} + V_{CC}$
Input Currents, (pin 3 and 5)	20 mA
Output Sinking Current	50 mA
Storage Temperature, $T_S$	-40 to +100 $^\circ\text{C}$
Ambient Temperature, operating, $T_A$	-25 to +85 $^\circ\text{C}$
Lead Solder Temperature, 230 $^\circ\text{C}$	<10 s
IC Junction Temperature, $T_J$	125 $^\circ\text{C}$
Average IR LED Current, DC, $I_{LED}$	100 mA
Repetitive Pulsed IR LED Current, $I_{LED(RP)}$	700 mA
$<90\ \mu\text{s}, t_{on} < 25\%$	
Transmit Data Input Voltage, $V_{TXD}$	-0.5 to $V_{CC} + 0.5\text{ V}$
Receive Data Output Voltage, $V_{RXD}$	-0.5 to $V_{CC} + 0.5\text{ V}$

Table 1. Pin Functions

Pin no.	Function	Pin no.	Function
1	LED Anode	5	SD/Mode
2	LED Cathode	6	$V_{CC}$
3	TxD	7	*Do not connect
4	RxD	8	GND

\*Pin 7 internally grounded

**Figure 1. Block Diagram**



**Electrical Characteristics**

**Table 2. Basic Parameters,  $T_A=25^\circ\text{C}$  (except where noted)**

Parameter	Min.	Typ.	Max.	Unit	Conditions
Data Rate	9.6 K	—	4 M	bits/s	Standard pulse width
$V_{CC}$ Voltage	2.6	—	5.5	V	$-25$ to $+85^\circ\text{C}$ , $V_{CC}$ to $V_{SS}$
Maximum LED Anode Voltage	—	—	$4V + V_{CC}$	V	$V_{CC}=2.6$ V to 5.5 V
$I_{CC}$ Standby Current (Avg.)	—	3.3	4.5	mA	$SD=0$ , $V_{CC}=2.6$ V to 5.5 V, no receive signal
$I_{CC}$ Receiving Current (Avg.)	—	3.6	5.0	mA	$10\ \mu\text{W}$ , 4.0 Mb/s, 15 pF load
$I_{CC}$ Shut Down Current ( <b>Note 1</b> ) (Avg.)	—	0.01	1.0	$\mu\text{A}$	$SD=V_{CC}$ , $V_{CC}=2.6$ V to 5.5 V
$I_{CC}$ Transmitting Current (Avg.)	—	6	10	mA	$TxD=V_{CC}$ , $V_{CC}=5.0$ V, $V_{LED}=5.0$ V, $R_o=5.1\ \Omega$
Minimum $V_{CC}$	—	2.5	—	V	Reduced performance

**Table 3. I/O Parameters**

Parameter	Min.	Typ.	Max.	Unit	Conditions
TxD, SD Input Capacitance	—	5.0	—	pF	$V_{CC}=2.6$ V to 5.5 V
TxD pull-down	350	500	700	k $\Omega$	$TxD=V_{CC}$ , $V_{CC}=5.0$ V
Minimum dV/dt of TxD Input Signal	0.7	1.4	—	V/ $\mu\text{s}$	5.0 V pulse
TxD Minimum Hold Time for Mode Change	90	200	—	ns	$V_{CC}=2.6$ V to 5.5 V, referenced to SD negative clocking edge
TxD Minimum Setup Time for Mode Change ( <b>Note 2</b> )	-70	-40	—	ns	$V_{CC}=2.6$ V to 5.5 V, referenced to SD negative clocking edge
TxD Input Threshold	1.0	1.4	1.8	$V_{CC}$	$V_{CC}=2.6$ V to 5.5 V, 125 ns input pulse
SD Transmit Enable	—	500	—	ns	$V_{CC}=2.6$ V to 5.5 V, ( <b>Note 3</b> )
SD to TxD input disable & RxD tri-state	—	50	70	ns	$V_{CC}=2.6$ V to 5.5 V
SD Input Threshold	1.0	1.4	1.8	V	$V_{CC}=5.0$ V
SD Input Threshold	0.6	0.9	1.2	V	$V_{CC}=2.6$ V

**Table 3. I/O Parameters** (continued)

Parameter	Min.	Typ.	Max.	Unit	Conditions
RxD Output High	3.5	4.0	—	V	$V_{CC}=5.0\text{ V}$ , $I_{OH}=24\text{ mA}$
RxD Output High	2.0	2.3	—	V	$V_{CC}=2.7\text{ V}$ , $I_{OH}=6.0\text{ mA}$
RxD Output Low	—	1.0	1.5	V	$V_{CC}=5.0\text{ V}$ , $I_{OL}=24\text{ mA}$
RxD Output Low	—	0.1	0.8	V	$V_{CC}=5.0\text{ V}$ , $I_{OL}<1\text{ mA}$
RxD Output Low	—	0.4	0.8	V	$V_{CC}=2.7\text{ V}$ , $I_{OL}=6.0\text{ mA}$
RxD Short Circuit	—	48	—	mA	$V_{CC}=5.0\text{ V}$ , RxD=0, RxD= $V_{CC}$
RxD Short Circuit	—	48	—	mA	$V_{CC}=2.7\text{ V}$ , RxD=0, RxD= $V_{CC}$
RxD to $V_{CC}$ Tri-State Impedance	350	500	650	k $\Omega$	SD= $V_{CC}$ , $V_{CC}=5.0\text{ V}$ , measured between RxD to $V_{CC}$
RxD Rise/Fall Time	—	7.0	—	ns	$V_{CC}=5.0\text{ V}$ , load=15 pF
RxD Rise/Fall Time	—	15	—	ns	$V_{CC}=5.0\text{ V}$ , load=100 pF
RxD Rise/Fall Time	—	10	—	ns	$V_{CC}=2.7\text{ V}$ , load=15 pF
RxD Rise/Fall Time	—	27	—	ns	$V_{CC}=2.7\text{ V}$ , load=100 pF

**Table 4. Receiver Parameters, High Rate Mode (FIR),  $T_A=25^\circ\text{C}$**  (except where noted)

Parameter	Symbol	Min.	Typ.	Max.	Unit	Conditions
Data Rate	—	—	4 M	—	bit/s	125 ns (low rate pulse), 0 to $70^\circ\text{C}$
Logic High Input Irradiance	$E_{IHmin}$	10	—	—	$\mu\text{W}/\text{cm}^2$	Bit error rate= $10^{-8}$
Logic High Input Irradiance	$E_{IHmax}$	—	—	500	mW/cm <sup>2</sup>	In-band irradiance maximum
Minimum Detection Threshold	$E_{Emin}$	—	4.0	—	$\mu\text{W}/\text{cm}^2$	4.0 Mb/s
Logic Low Input Irradiance	$E_{IL}$	—	—	0.4	$\mu\text{W}/\text{cm}^2$	Ambient interference pulsed
Receive Latency (Near-far)	—	—	500	800	$\mu\text{s}$	0 to 10 mW/cm <sup>2</sup> ambient input
Powerup Latency	—	—	50	100	$\mu\text{s}$	0 to 10 mW/cm <sup>2</sup> ambient input
Transmit Latency (turn around)	—	—	30	50	$\mu\text{s}$	0 to 10 mW/cm <sup>2</sup> ambient input
Pulse Width Correction Range	—	90	—	175	ns	40 $\mu\text{W}/\text{cm}^2$ input to produce 115 ns to 135 ns output, $V_{CC}=2.7\text{ V}$ to 5.5 V
Pulse Width Settling	—	—	8.0	16	$\mu\text{s}$	40 $\mu\text{W}/\text{cm}^2$ input
Output Pulse Edge Jitter & Bias at RxD	—	—	10	—	ns	125 ns, 40 $\mu\text{W}/\text{cm}^2$ input, load=15 pf, measured at 1.4 V
Output Pulse Width at RxD	—	110	125	140	ns	125 ns, 40 $\mu\text{W}/\text{cm}^2$ input, load=15 pf, measured at 1.4 V
Power Supply Rejection <5 MHz	—	—	50	—	mV <sub>P</sub>	<0.1 pulse per second spurious output
Power Supply Rejection >5 MHz	—	—	25	—	mV <sub>P</sub>	<0.1 pulse per second spurious output

**Table 5: Receiver Parameters, Low Rate Mode (SIR/MIR),  $T_A=25^\circ\text{C}$**  (except where noted)

Parameter	Symbol	Min.	Typ.	Max.	Unit	Conditions
Data Rate	—	9.6 K	—	1.15 M	bits/s	9.6 Kb/s to 115 Kb/s=1.63 $\mu\text{s}$ , 576 Kb/s=434 ns, 1.152 Mb/s=217 ns
Logic High Input Irradiance (MIR)	$E_{IHmin}$	10	—	—	$\mu\text{W}/\text{cm}^2$	Bit error rate= $10^{-8}$
Logic High Input Irradiance (SIR)	$E_{IHmin}$	4.0	—	—	$\mu\text{W}/\text{cm}^2$	Bit error rate= $10^{-8}$
Logic High Input Irradiance	$E_{IHmax}$	—	—	500	mW/cm <sup>2</sup>	In band irradiance maximum
Logic Low Input Irradiance	$E_{IL}$	—	—	0.4	$\mu\text{W}/\text{cm}^2$	Ambient interference pulsed
Receive Latency (Near-far)	—	—	2.5	4.0	ms	0 to 10 mW/cm <sup>2</sup> ambient input
Transmit Latency (turn around)	—	—	50	100	$\mu\text{s}$	0 to 10 mW/cm <sup>2</sup> ambient input
Power-up Latency	—	—	50	150	$\mu\text{s}$	0 to 10 mW/cm <sup>2</sup> ambient input
Power Supply Rejection <5 MHz	—	—	50	—	mV <sub>P</sub>	<0.1 pulse per second spurious output
Power Supply Rejection >5 MHz	—	—	25	—	mV <sub>P</sub>	<0.1 pulse per second spurious output

**Table 5: Receiver Parameters, Low Rate Mode (SIR/MIR),  $T_A=25^\circ\text{C}$  (except where noted) (Continued)**

Output Pulse Width (1.15 MB)	—	120	215	400	ns	217 ns pulse in
Output Pulse Width at RxD (115 Kb/s)	—	1.4	1.63	2.5	$\mu\text{s}$	1.63 ns pulse in
Output Pulse Width at RxD (9.6 Kb/s)	—	1.4	6	22	$\mu\text{s}$	19.5 $\mu\text{s}$ pulse in

**Table 6. Transmitter Output**

Parameter	Min.	Typ.	Max.	Unit	Conditions
Transmit Delay	—	15	—	ns	125 ns pulse, $V_{CC}=5.0\text{ V}$
Pulse Width Limit	50	70	100	$\mu\text{s}$	TxD pulse > 100 $\mu\text{s}$ , 5.0 V pulse, $V_{CC}=5.0\text{ V}$
TxD Peak Wavelength	850	870	900	nm	$I_F=20\text{ mA DC}$
LED Anode Current Limit	510	610	680	mA	TxD= $V_{CC}$ , LED anode=5.0 V, $V_{CC}=5.0\text{ V}$ , averaged over 125 ns pulse
LED Anode Current Limit	310	450	550	mA	TxD= $V_{CC}$ , LED anode=3.0 V, $V_{CC}=3.0\text{ V}$ , averaged over 125 ns pulse
$V_{CC}$ Transient Immunity	$V_{CC} \pm 1$	$V_{CC} \pm 2$	—	V peak	10 ns pulse height, $V_{CC}=5.0\text{ V}$ (Note 4)
Transmit output rise and fall time ( $t_r, t_f$ )	10	—	40	ns	$V_{LED}=2.7\text{ V}$ , no resistor
Radiant Intensity (peak, 4 Mb/s mode)	100	170	400	mW/sr	$V_{LED}=2.7\text{ V}$ , no resistor

**Note 1:**

For Shut Down (SD) current to fall below  $1\mu\text{A}$  requires driving the Shut Down (SD) pin to within 0.5 V of  $V_{CC}$  to ensure cutoff of the input PMOS transistor of the input CMOS totem pole.

**Note 2:**

Negative setup times indicate that the internal data propagation time is longer than the latching signal propagation time. This is common on logic devices. It means that the TxD data can go away before the negative Shut Down (SD) edge occurs and not lose the data. (See application notes for more details).

**Note 3:**

Shut Down (SD) to transmit enable is the time required for the transmit bias circuits to stabilize. Applying a transmit pulse before this time has elapsed will reduce the transmit pulse width.

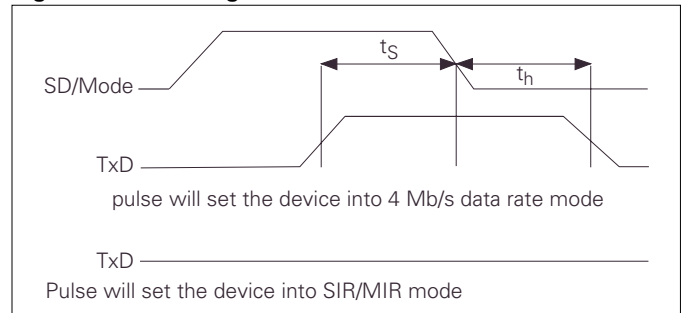
**Note 4:**

Transmit  $V_{CC}$  Transient Immunity measures the transmitter circuitry immunity from large  $V_{CC}$  and ground return inductive transients arising from the action of large transmitter di/dt currents on  $V_{CC}$  and ground return trace inductances. This test applies a negative 10 ns  $V_{CC}$  pulse to simulate the effects of transmitter current induce  $V_{CC}$  transients (assuming the LED anode supply and  $V_{CC}$  have a shared inductance) and measures for less than a 10% change in pulse width or delivered charge on the initial pulse and subsequent pulse.

**Mode Switching** (see Figure 2.)

Normally the IRMS6400/IRMT6400 Series initializes in the SIR/MIR (9.6 Kb/s to 1.152 Mb/s) mode upon power-up. Switching the module to FIR (4 Mb/s) Mode can be achieved as follows:

- Bring Shut Down (SD)/Mode pin to a logic "High" status.
- Bring TxD input to a logic "High" status. Wait for  $t_s \geq 40\text{ ns}$ .
- Bring Shut Down (SD)/Mode pin to a logic "Low" status. The negative transition of this pulse will set the module mode to (4 Mb/s) data rate by reading the state of TxD. Bring TxD to a logic "Low" after waiting for  $t_h \geq 90\text{ ns}$ .

**Figure 2. Switching Mode**

Switching to SIR/MIR (9.6 Kb/s to 1.15 Mb/s) Mode:

- Bring Shut Down (SD)/Mode pin to a logic "High" status.
- Bring TxD input to a logic "Low" status. Wait for  $t_s \geq 40\text{ ns}$ .
- Bring Shut Down (SD)/Mode pin to a logic "Low" status. The negative transition of this pulse will set the module mode to 115 Kb/s data rate by reading the state of TxD.

Figure 3. Shutdown Current vs. Ambient Temperature

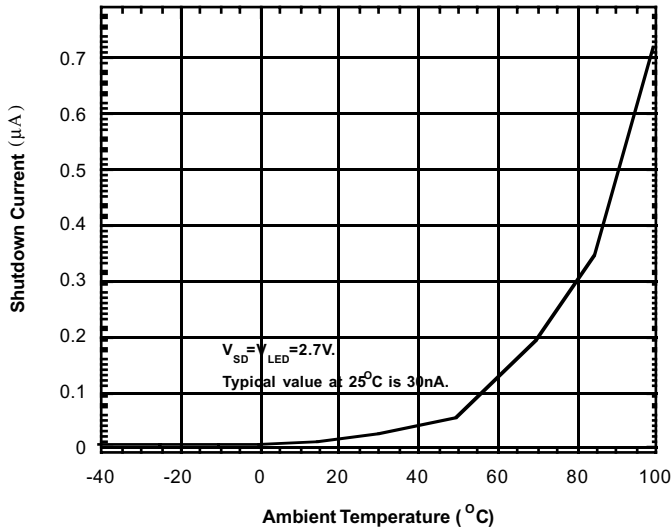


Figure 6. Rx/D Pulse Width vs. Ambient Temperature

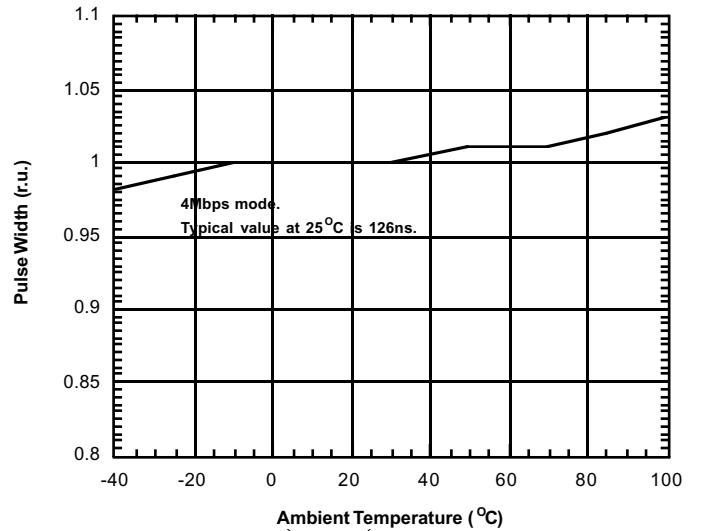


Figure 4. Standby Current vs. Temperature

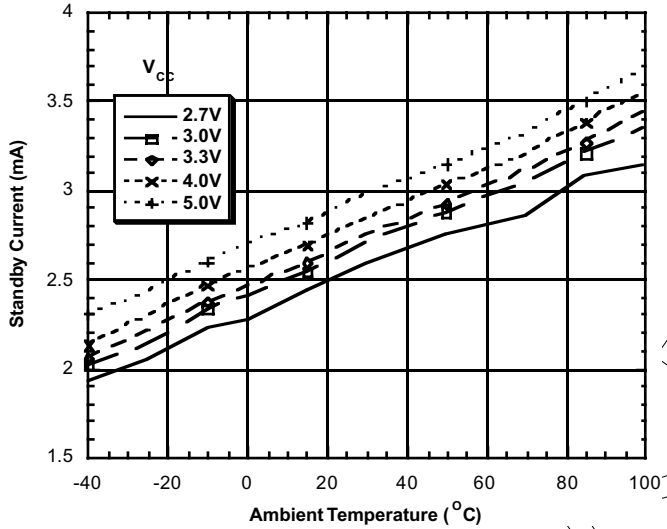


Figure 7. Rx/D Pulse Rise and Fall Time vs. Temperature

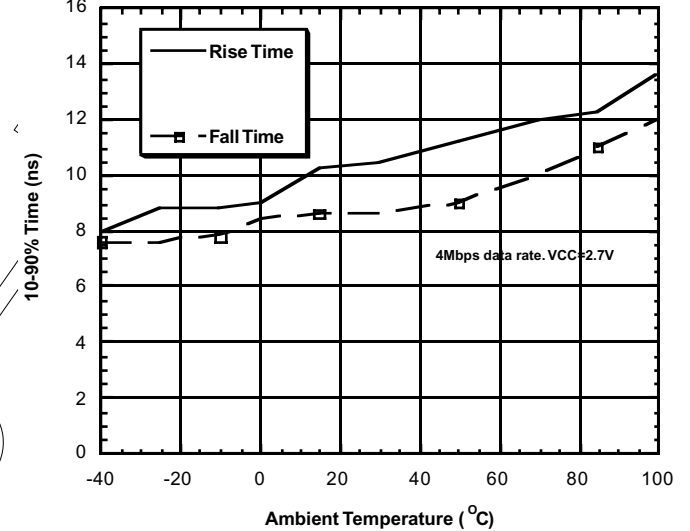


Figure 5. Rx/D Pulse Width vs. Ambient Temperature

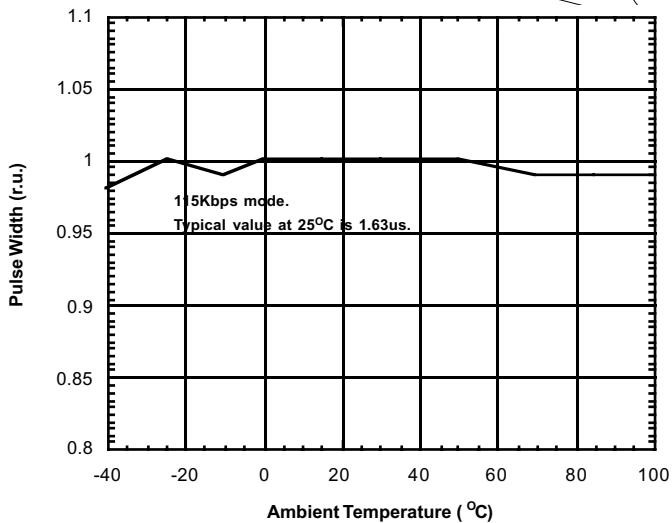
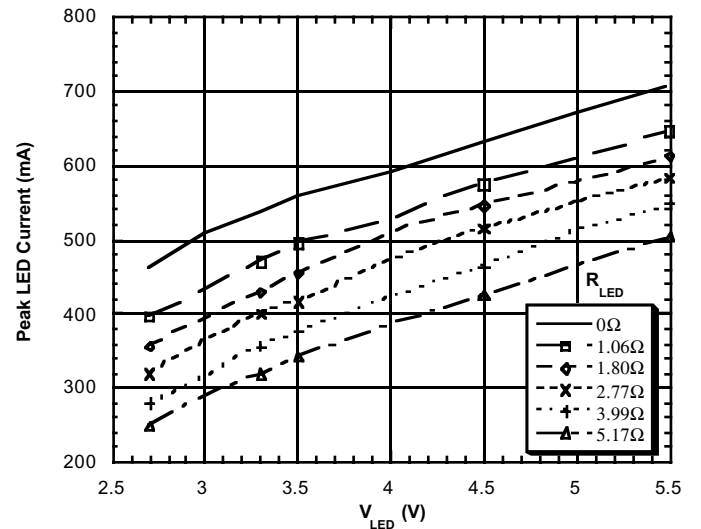
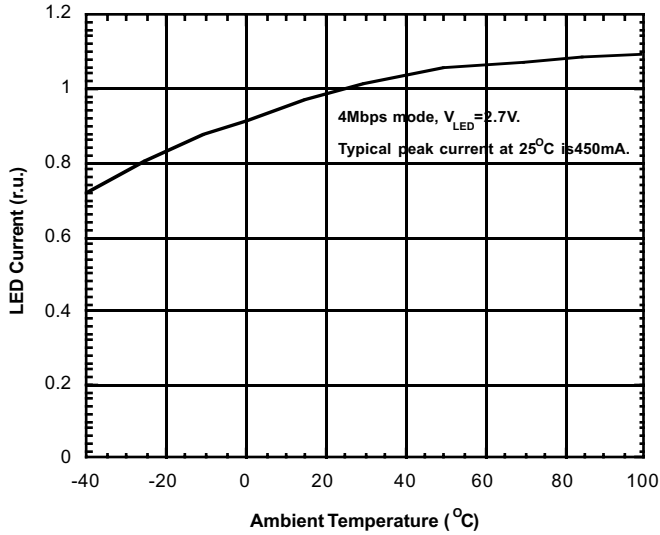


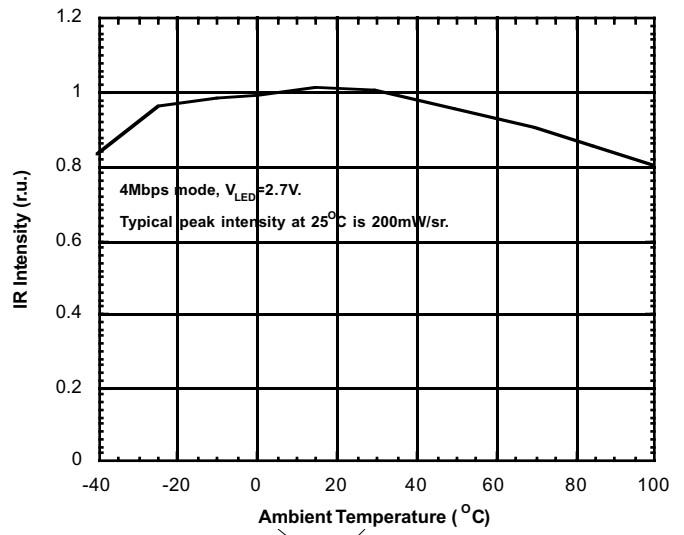
Figure 8. LED Peak Current vs. V\_LED



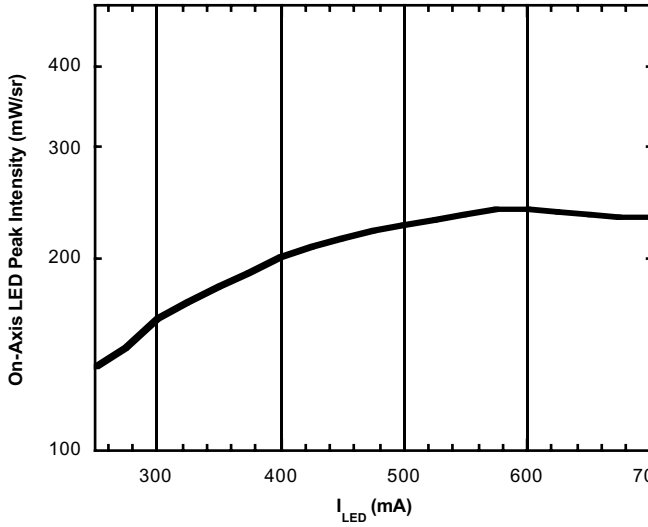
**Figure 9. LED Current vs. Ambient Temperature**



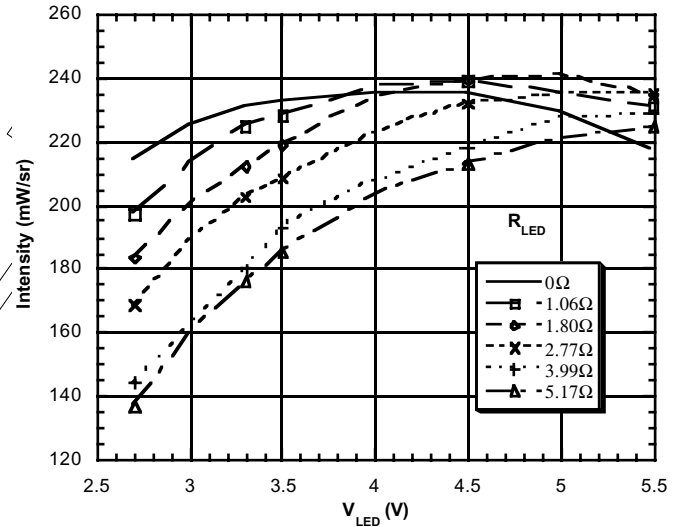
**Figure 12. IR Intensity vs. Ambient Temperature**



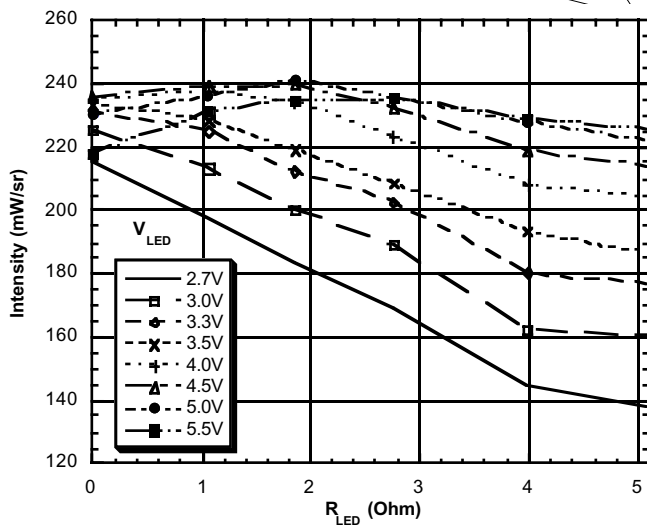
**Figure 10. Peak Intensity vs. LED peak Current**



**Figure 13. LED Intensity vs. V\_LED**



**Figure 11. LED Intensity vs. R\_LED**



**Figure 14. Farfield Receiver Sensitivity Pattern (FIR)**

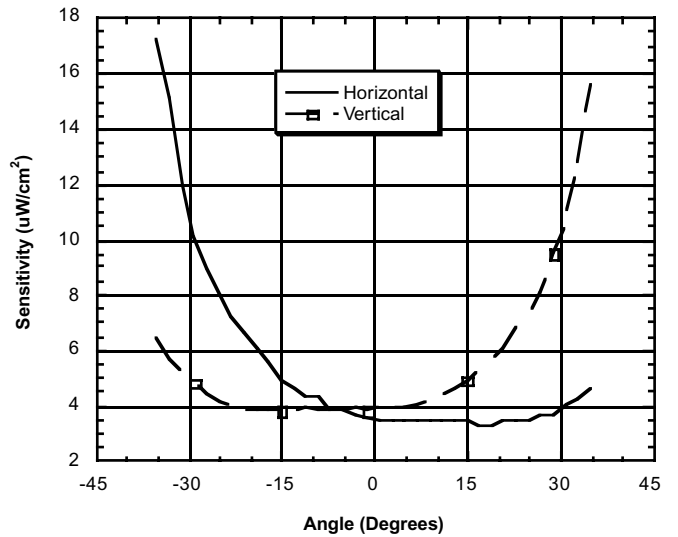


Figure 15. Receiver Sensitivity vs. Temperature (115 Kb/s)

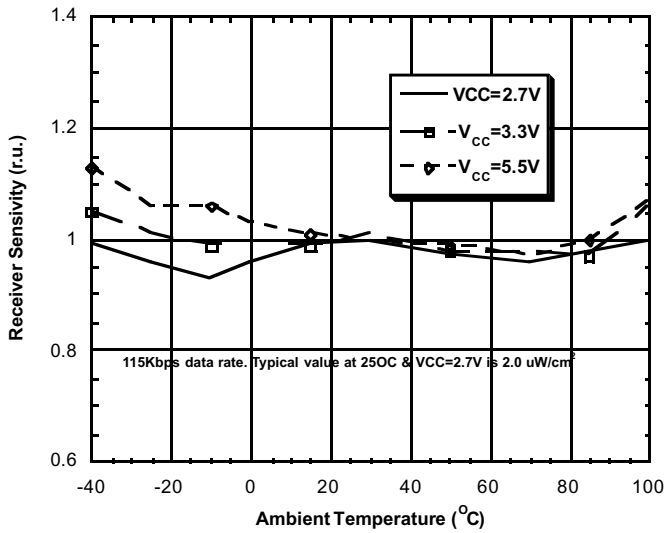


Figure 18. RxD Pulse Rise and Fall Time vs. Temperature

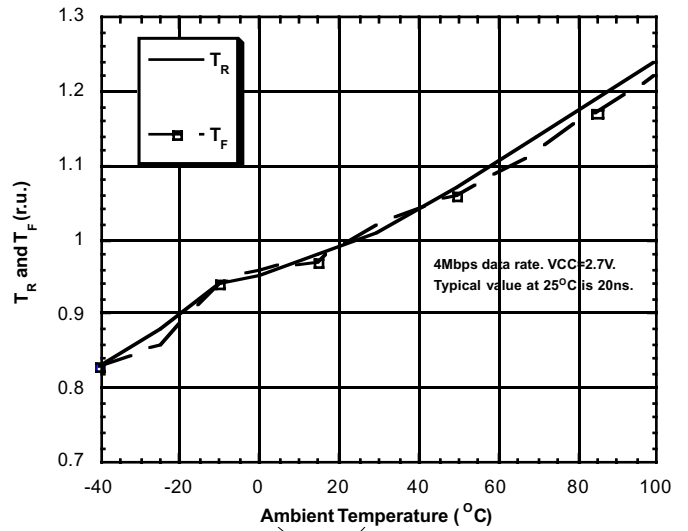


Figure 16. Receiver Sensitivity vs. Temperature

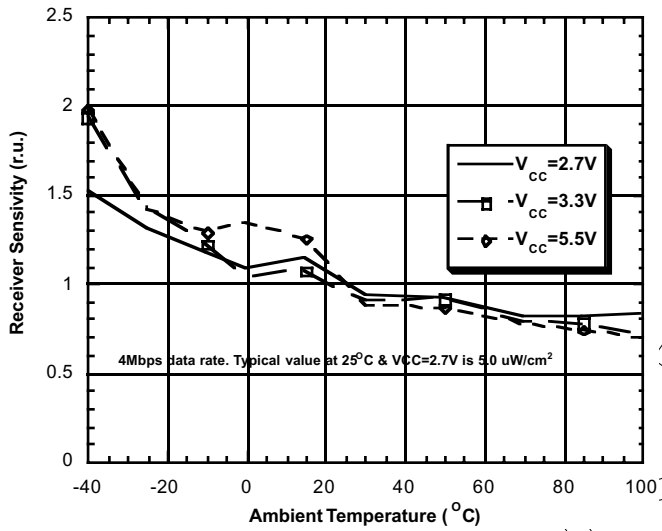
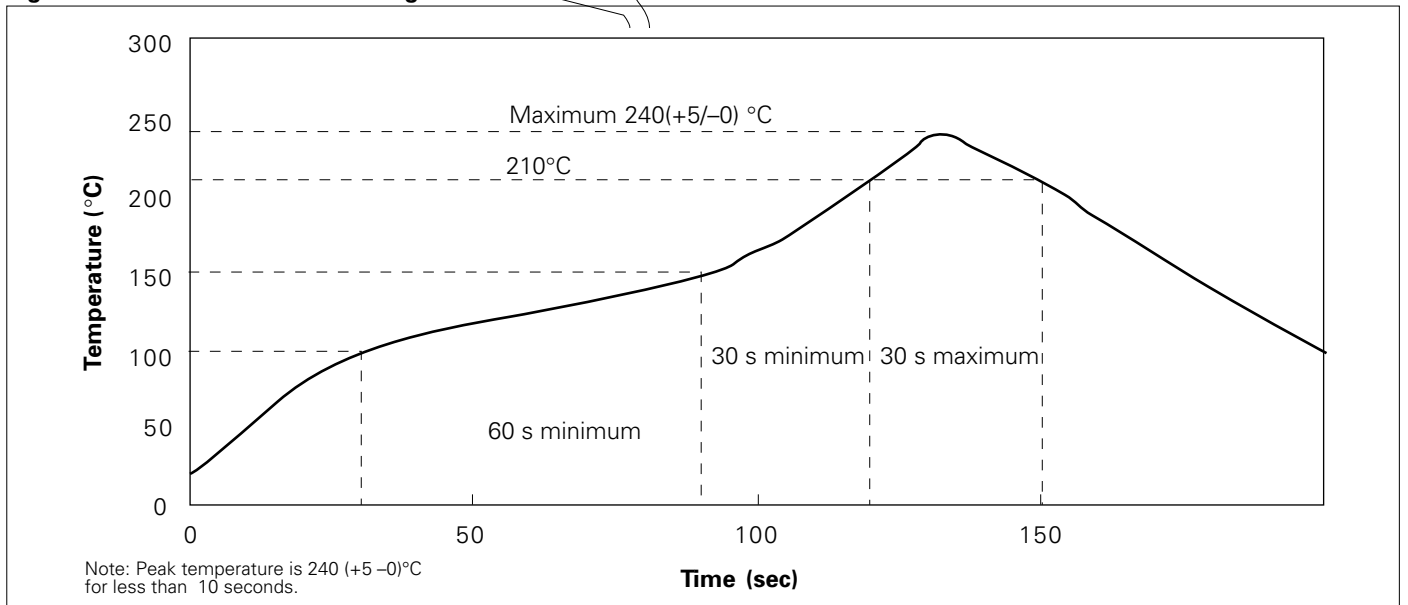
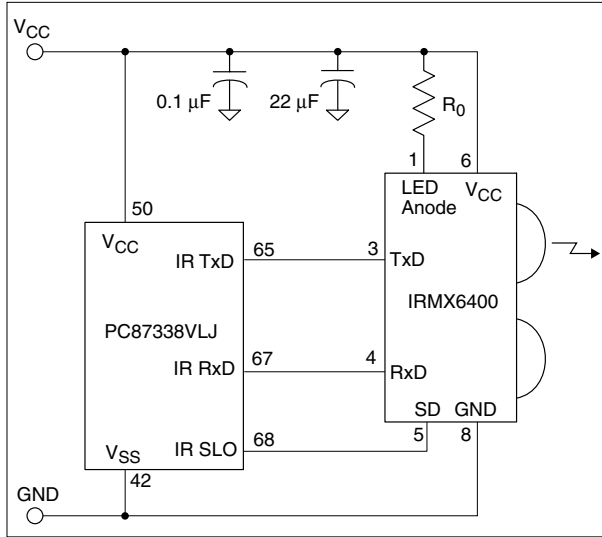


Figure 17. Infrared Reflow Soldering Profile

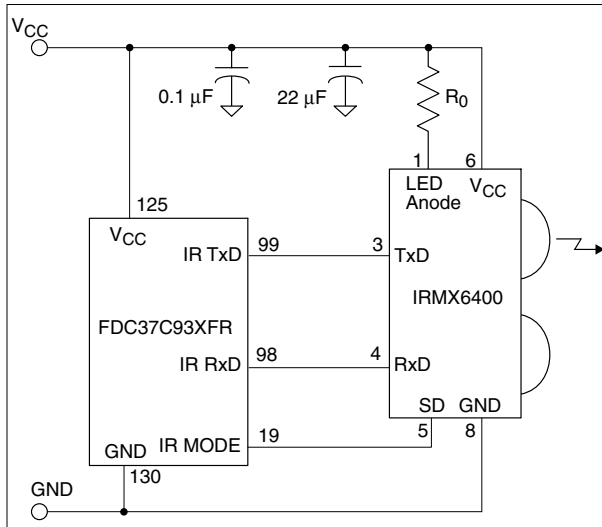


**Interface Diagrams**

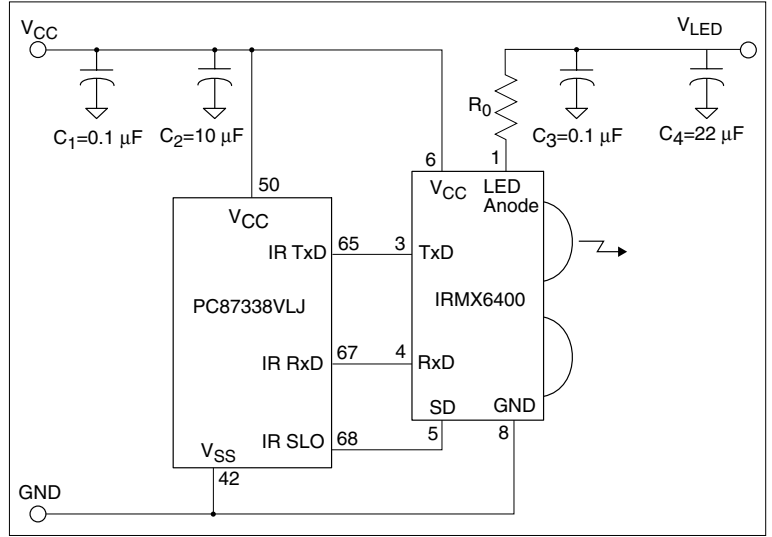
**Figure 19. Super I/O (PC87338VLJ) to IRMS6400/IRMT6400**



**Figure 20. Ultra I/O controller with fast IR (FDC37C93xFR) to IRMS6400/IRMT6400**



**Figure 21. Super I/O (PC87338VLJ) to IRMS6400/IRMT6400 with independent V<sub>LED</sub> power supply**



**Table 7. Recommended R<sub>0</sub> values for different V<sub>LED</sub>**

Parameter	Values							Unit
V <sub>LED</sub> power supply	2.4	2.7	3.0	3.5	4.0	4.5	5.0	V
Resistor	0	0	0	1.2	2.7	3.9	5.1	Ω

**Table 8. Slimline IRMS64XX Truth Table**

Inputs			Outputs		
SD	V <sub>CC</sub>	TxD	Detector	RxD	LED
High	2.4 to 5.5 V	X=don't care state	X=don't care state	500 kΩ pull-up	Off
Low	2.4 to 5.5 V	High		Undefined	On
	2.4 to 5.5 V	Low	<0.4 μW/cm <sup>2</sup> (115 Kb/s)	High	Off
Low	2.4 to 5.5 V	Low	<1.0 μW/cm <sup>2</sup> (1 & 4 Mb/s)		
	2.4 to 5.5 V	Low	<4.0 μW/cm <sup>2</sup> (115 Kb/s)	Low	Off
Low	2.4 to 5.5 V		<10.0 μW/cm <sup>2</sup> (1 & 4 Mb/s)		

www.vishay.com

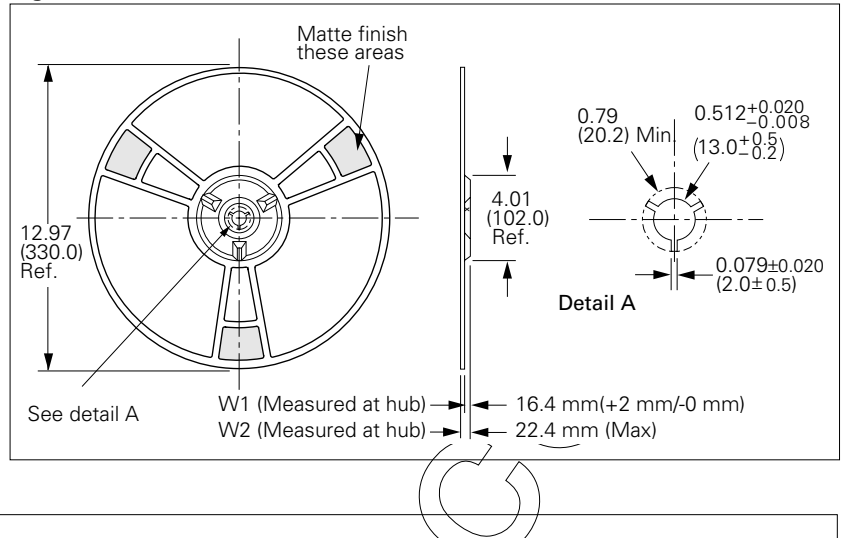


### Ordering Information

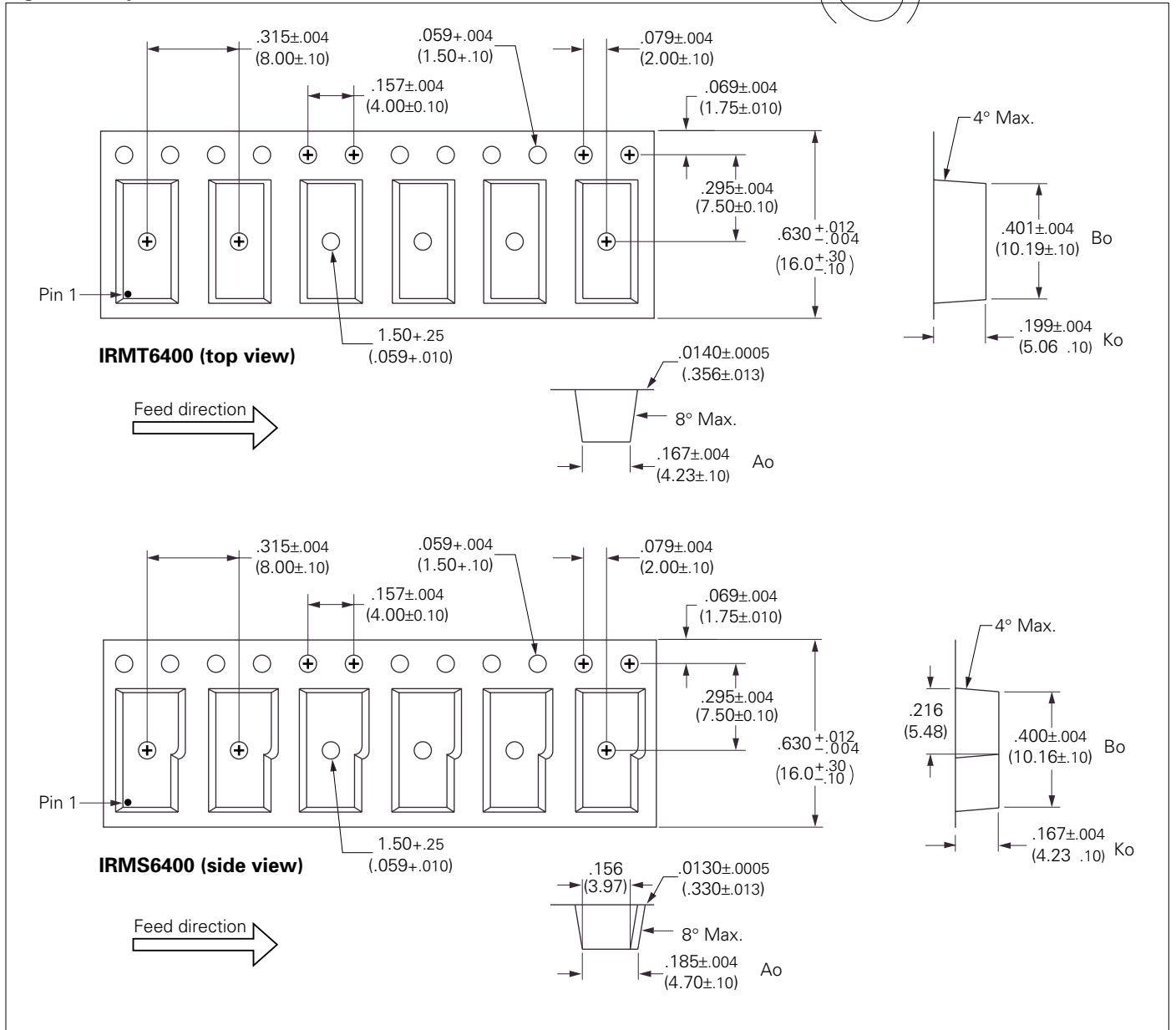
Part Number	Description	PCB Mounting Orientation
IRMS6400	Integrated Transceiver —Side View	Packaged in Component Carrier Reel (1000/reel) for Side View Mounting on PCB
IRMT6400	Integrated Transceiver —Top View	Packaged in Component Carrier Reel (1000/reel) for Top View Mounting on PCB

Tape Leader and Trailer is 400 mm minimum.

**Figure 23. Reel Dimensions in Inches (mm)**

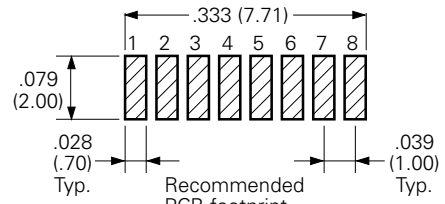
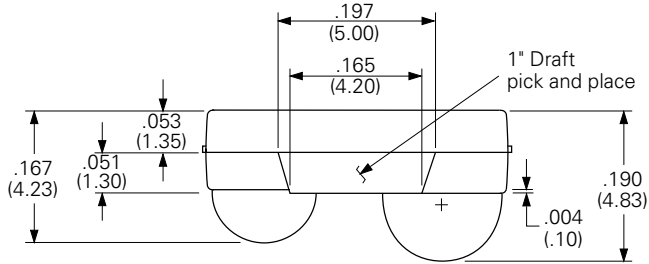


**Figure 22. Tape Dimensions in Inches (mm)**

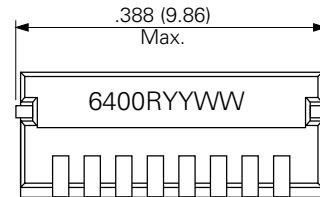
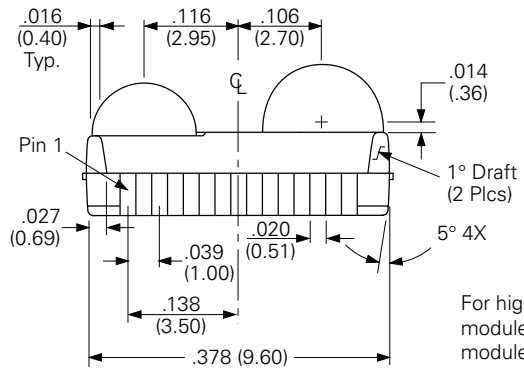
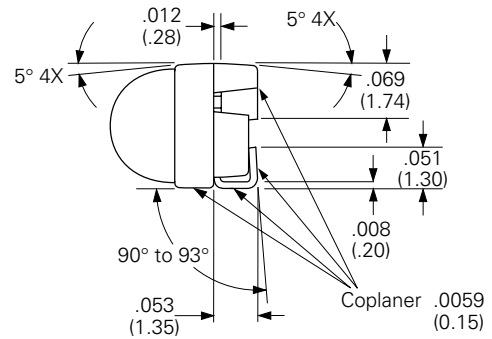
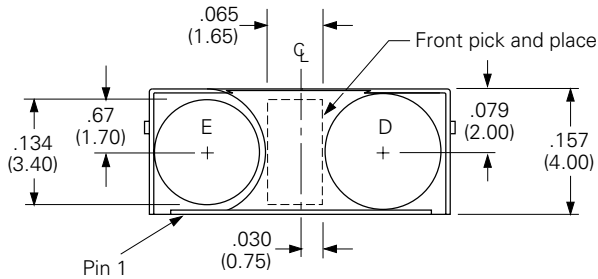


**Figure 24. IRMS6400/IRMT6400 detail drawings with optional side view or top view mounting**

Dimensions in inches (mm)—All dimensions have tolerances of  $\pm 0.004$ " ( $\pm 0.1$  mm)



TOP VIEW



For high EMI environment application the IRMS6400 and IRMT6400 modules are available with a metal can shield. The metal shielded modules are designated as IRMS6409 and IRMT6409 respectively.

