

GP1F31T/R, GP1F32T/R, GP1F33TT/RR/RT, GP1C331/331A/335

Light Transmitting /Receiving Units

■ Features

1. Low jitter (Δt_j : TYP. 1ns)
2. High speed signal transmission
(8Mbps, NRZ signal)
3. Directly connectable to modulation
/demodulation IC for digital audio equipment
 - Light transmitting unit*** Built-in light emitting diode driving circuit
 - Light receiving unit*** Built-in signal processing circuit
4. With two fixing holes for easy mounting
on set panel
(GP1F32T/GP1F32R/GP1F33RR/
GP1F33TT/33RT)
5. 2-channel type
(GP1F33RR/GP1F33TT/GP1F33RT)

* We recommend you to use Sharp's optical fiber cable, (GP1C331, GP1C331A, GP1C335)

■ Applications

1. CD players
2. BS tuners
3. Digital amplifiers

■ Model Line-ups

Model No.	Internal Constitution
GP1F31T	Light transmitting unit
GP1F31R	Light receiving unit
GP1F32T	Light transmitting unit
GP1F32R	Light receiving unit
GP1F33TT	Dual light transmitting unit
GP1F33RR	Dual light receiving unit
GP1F33RT	Light transmitting & receiving units
GP1C331	Optical fiber cable (1m)
GP1C331A	Optical fiber cable (0.6m)
GP1C335	Optical fiber cable (5m)

■ Outline Dimensions

(Unit : mm)

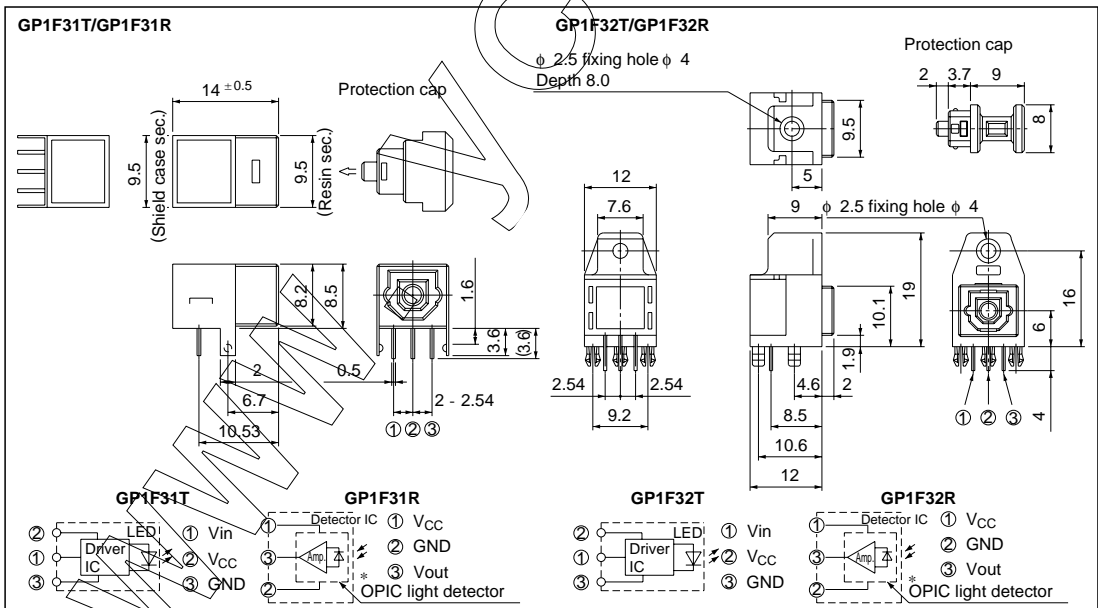

* OPIC is a trademark of Sharp and stands for Optical IC.

It has light detecting element and signal processing circuitry integrated single chip.

■ Outline Dimensions

(Unit : mm)

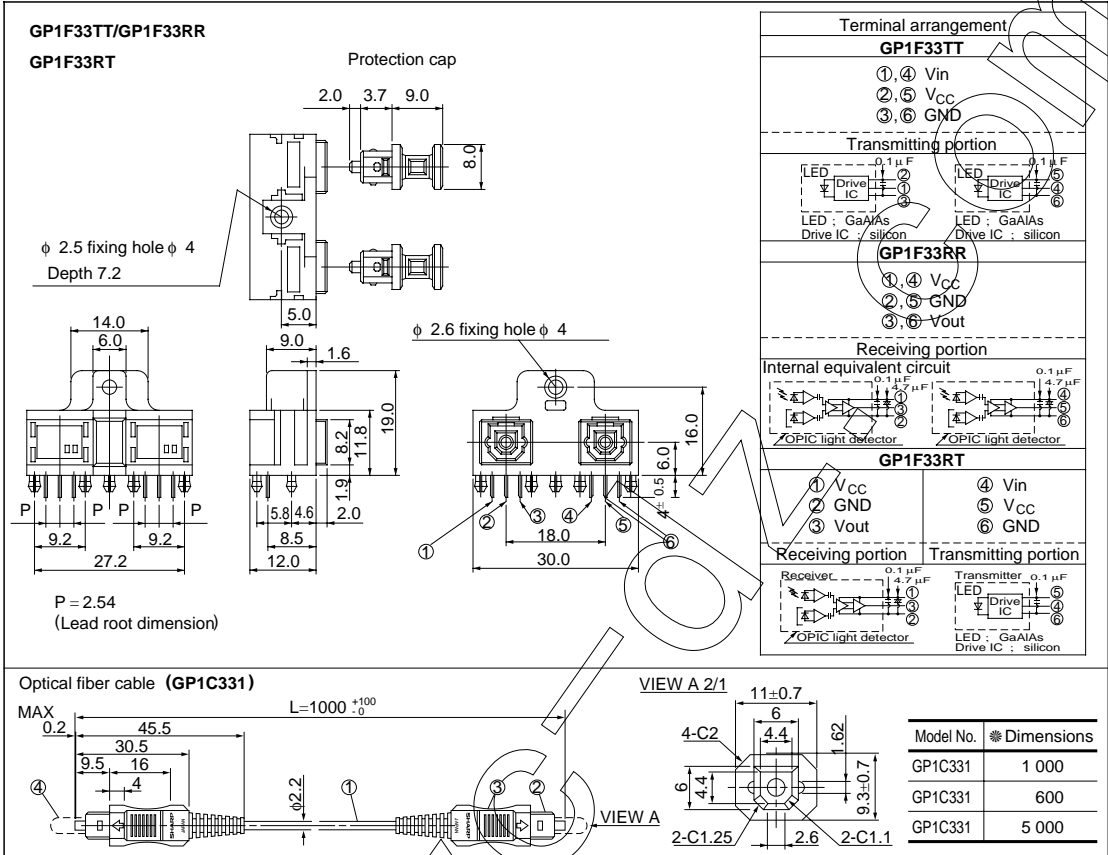

■ Absolute Maximum Ratings

(Ta = 25°C)

Parameter	Symbol	Rated	Unit
Supply voltage	V _{CC}	- 0.5 to + 7	V
Input voltage	*4 V _{in}	- 0.5 to V _{CC} + 0.5	V
Power dissipation	*4 P	125	mW
*1 High level output current	*5 I _{OH}	4	mA
*2 Low level output current	*5 I _{OL}	4	mA
Operating temperature	*6 T _{opr}	- 10 to + 60	°C
	*7	- 20 to + 70	°C
Storage temperature	T _{stg}	- 30 to + 80	°C
*3 Soldering temperature	T _{sol}	260	°C

*1 Source current

*3 5 seconds/time up to 2 times

*4 GP1F31T/GP1F32T/GP1F33TT/Transmitting portion of GP1F33RT

*5 GP1F31R/GP1F32R/GP1F33RR/Receiving portion of GP1F33RT

*6 GP1F31T/GP1F31R

*7 GP1F32T/GP1F32R/GP1F33TT, GP1F33RR, GP1F33RT

Fiber cable (GP1C331, GP1C331A, GP1C335)

Parameter	Symbol	Rating	Unit
Tension	Plug & optical fiber	T _{pf}	40 N
	Optical fiber	T _f	40 N
Bending radius	R	25 Min.	mm
Operating temperature	T _{opr}	- 30 to + 70	°C
Storage temperature	T _{stg}	- 30 to + 70	°C

Electro-optical Characteristics

(1) Transmitter

GP1F31T/GP1F32T/GP1F33TT/ Transmitting portion of GP1F33RT

 $(T_a = 25^\circ\text{C})$

Parameter	Symbol	Conditions	MIN.	TYP.	MAX.	Unit
Operating voltage	V_{CC}	-	4.75	5.00	5.25	V
Peak emission wavelength	λ_P	-	630	660	690	nm
Fiber coupling light output	P_C	*7	- 21	- 17	- 15	dBm
Dissipation current	I_{CC}	*8	-	4	10	mA
High level input voltage	V_{IH}	*8	2	-	-	V
Low level input voltage	V_{IL}	*8	-	-	0.8	V
“ Low→High ” propagation delay time	t_{PLH}	*9	-	-	100	ns
“ High→Low ” propagation delay time	t_{PHL}	*9	-	-	100	ns
Pulse width distortion	Δ_{tw}	*9	-25(-30)**	-	-25(-30)**	ns
Jitter	Δ_{tj}	*10	-	1	25(30)**	ns
Operating transfer rate	T	-	-	-	8	Mbps

** Value in parenthesis: GP1F31T

(2) Receiver

GP1F31R/GP1F32R/GP1F33RR/Receiving portion of GP1F33RT

 $(T_a = 25^\circ\text{C})$

Parameter	Symbol	Conditions	MIN.	TYP.	MAX.	Unit
Operating voltage	V_{CC}	-	4.75	5.00	5.25	V
Peak sensitivity wavelength	λ_P	-	-	700	-	nm
Maximum input optical power level for receiving unit	$P_{C_{MAX}}$	*11	- 14.5	-	-	dBm
Minimum input optical power level for receiving unit	$P_{C_{MIN}}$	*11	-	-	- 24	dBm
Dissipation current	I_{CC}	*12	-	15	40	mA
High level output voltage	V_{OH}	*13	2.7	3.5	-	V
Low level output voltage	V_{OL}	*13	-	0.2	0.4	V
Rise time	t_r	*13	-	12	30	ns
Fall time	t_f	*13	-	4	30	ns
“ Low→High ” propagation delay time	t_{PLH}	*13	-	-	100	ns
“ High→Low ” propagation delay time	t_{PHL}	*13	-	-	100	ns
Pulse width distortion	Δ_{pw}	*13	- 30	-	+ 30	ns
Jitter	Δ_{tj}	*14 $P_C = -15\text{dBm}$	-	1	30	ns
		*14 $P_C = -24\text{dBm}$	-	-	30	ns
Operating transfer rate	T	NRZ. duty 50% input	0.1	-	8	Mbps

*7 Measuring method of optical output coupling fiber

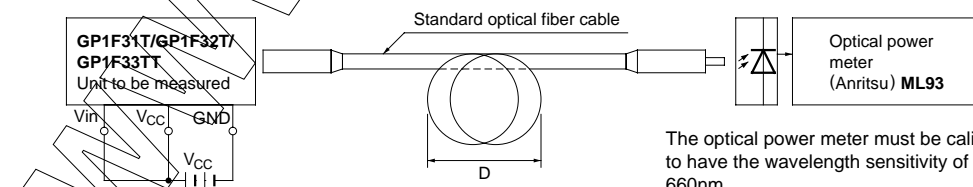

Note 1) $V_{CC} = 5.0 \pm 0.05\text{V}$ (Operating)

2) To bundle up the standard fiber cable, make it into a loop with the diameter (D) of 10cm or more.

The optical power meter must be calibrated to have the wavelength sensitivity of 660nm.
(0dBm = 1mW)

*8 Input voltage/power dissipation measuring method

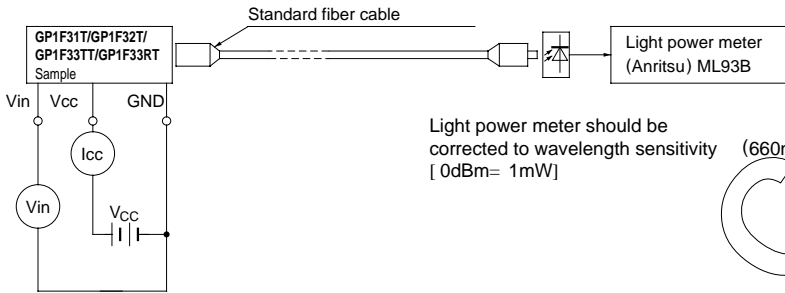

Input condition and measuring method

Input condition	Measuring method
$V_{in} = 2.0V$ or more	$-21 \leq P_c \leq -15dBm$, $I_{cc} = 10mA$ or less
$V_{in} = 0.8V$ or less	$P_c \leq -36dBm$, $I_{cc} = 10mA$ or less

Note (1) $V_{CC} = 5.0 \pm 0.05V$ (ON-State)

*9 Pulse response measuring method

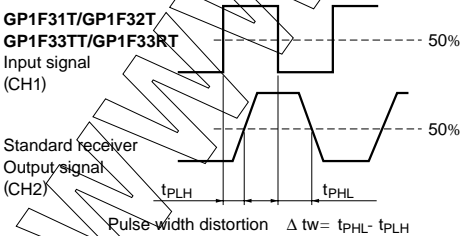
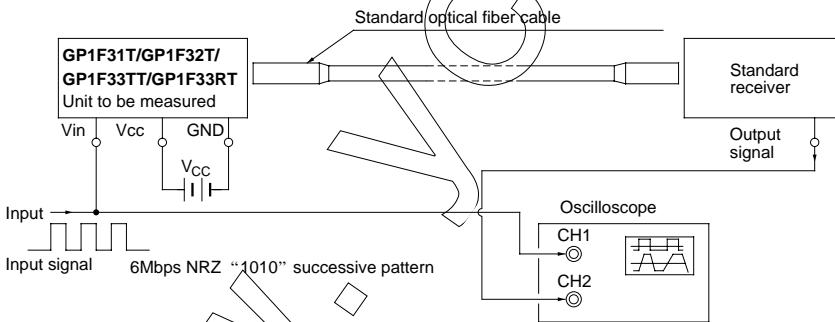

- Note 1) $V_{CC} = 5.0 \pm 0.05V$ (Operating)
- 2) The probe for the oscilloscope must be more than $1M\Omega$ and less than $10pF$.

*10 Jitter measuring method

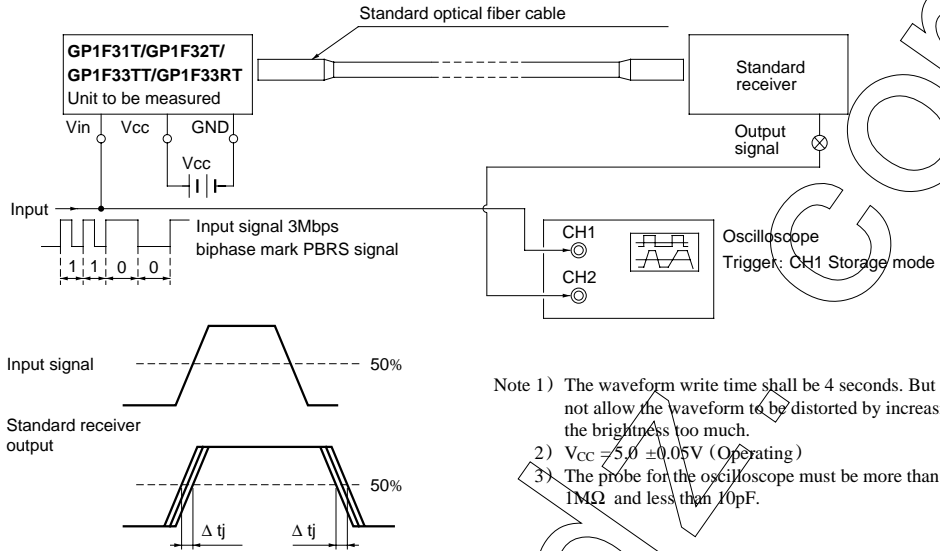

*11 Maximum input optical power level/Minimum input optical power level measuring method of receiving unit

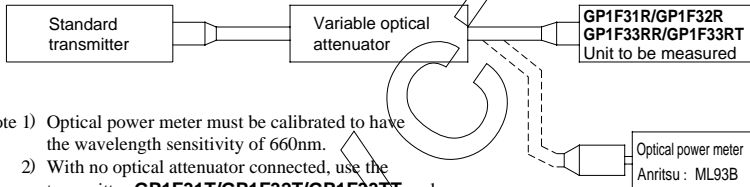

- Note 1) Optical power meter must be calibrated to have the wavelength sensitivity of 660nm.
2) With no optical attenuator connected, use the transmitter **GP1F31T/GP1F32T/GP1F33TT** and the optical fiber cable **GP1C331** with the fiber coupling light output set at -15dBm ~ -24dBm.

*12 Dissipation current measuring method

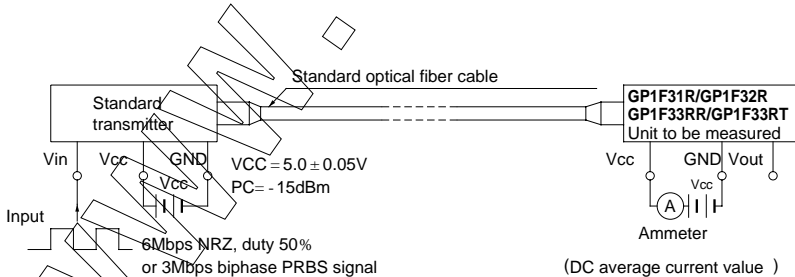

*13 Output voltage/Pulse response measuring method

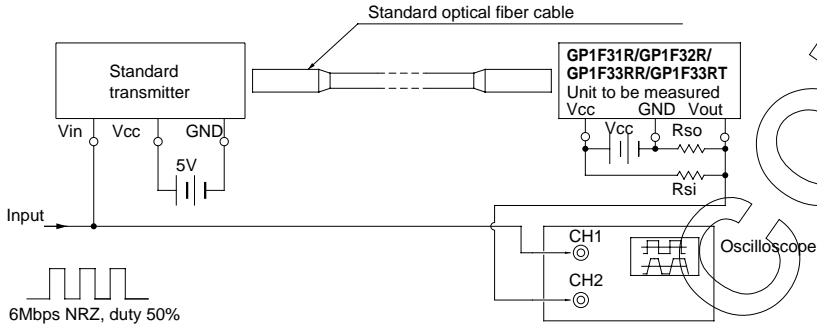

Standard transmitter
Input signal
(CH1)

GP1F31R/GP1F32R
GP1F33RR/GP1F33RT
Output signal
(CH2)

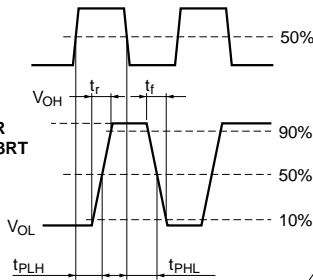

- Notes
- 1) $V_{CC} : 5.0 \pm 0.05V$ (Operating)
 - 2) The probe for the oscilloscope must be more than $1M\Omega$ and less than $10pF$.
 - 3) R_{si}, R_{so} : Standard load resistance ($R_{si} : 3.3k\Omega / R_{so} : 2.2k\Omega$)

*14 Jitter measuring method

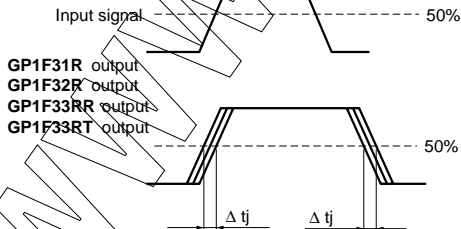
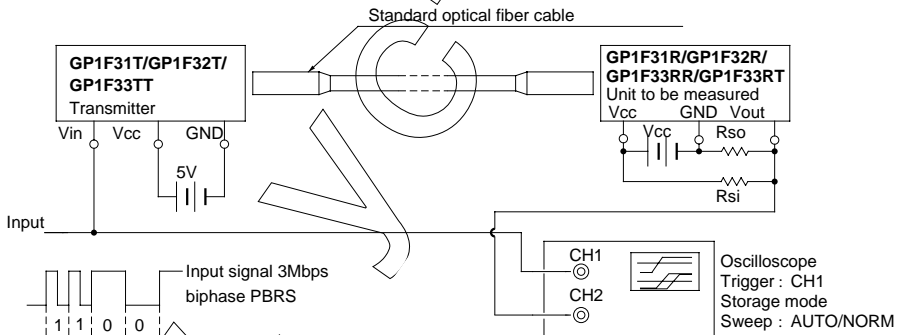

- Notes
- 1) R_{si}, R_{so} : Standard load resistance ($R_{si} : 3.3\Omega / R_{so} : 2.2k\Omega$)
 - 2) $V_{CC} = 5.0 \pm 0.05V$ (Operating)
 - 3) Set the oscilloscope to be storage mode and write time to 3 seconds. Do not allow the waveform to be distorted by increasing the brightness too much
 - 4) The probe for oscilloscope must be more than $1M\Omega$ and less than $10pF$.

(3) Optical Fiber Cable

Parameter	Symbol	MIN.	TYP.	MAX.	Unit
Optical output coupling fiber	Pc	- 17	-		dBm
Refracting ratio distribution	-	Step index			-

Measuring method for optical output coupling fiber

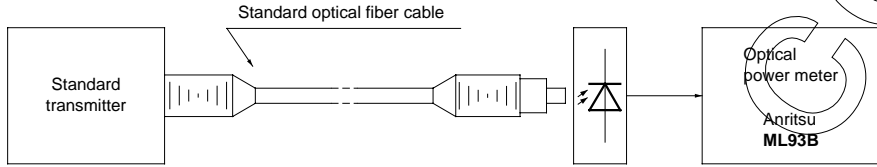

Standard light transmitter: Light transmitter that provides the fiber-end optical output of $-15\text{dBm} \pm 0.3\text{dBm}$ when the standard optical fiber cable is connected.

■ Mechanical Characteristics

Parameter	Symbol	Condition	MIN.	TYP.	MAX.	Unit
Inserting power disconnecting power	-	In compliance with EIAJ RC-5720 Initial value when a square connector is used.	6	-	40	N

■ System Configuration Example

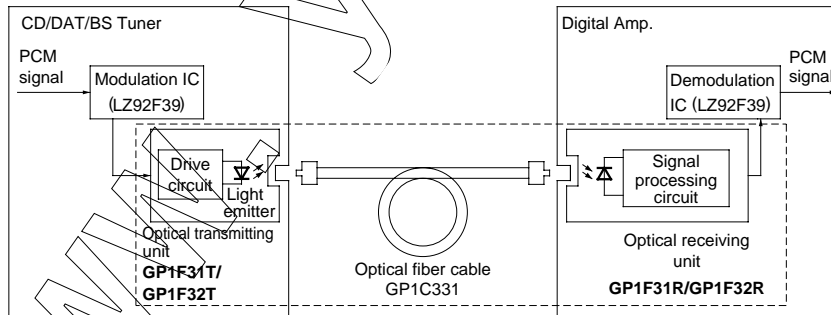

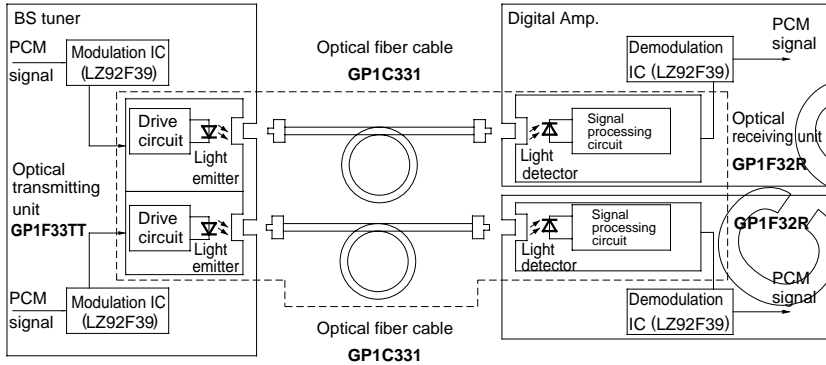

*LZ92F39 is Sharp's modulation/demodulation IC.

In addition, you can also choose the following system configuration according to your application.

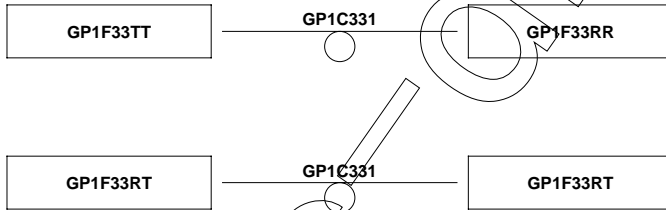

- Please refer to the chapter “Precautions for Use”

www.