

## Request For Quotation

Order the parts you need from our real-time inventory database. Simply complete a request for quotation form with your part information and a sales representative will respond to you with price and availability.

[Request For Quotation](#)

**Your free datasheet starts on the next page.**

More datasheets and data books are available from our homepage: <http://www.datasheetarchive.com>

# IrDA® Data 1.2 Compliant 115.2 Kb/s Infrared Transceiver

## Technical Data

### HSDL-3200

#### Features

- Fully Compliant to IrDA Data 1.2 Low Power Specifications
- Ultra Small Package
- Minimal Height: 2.5 mm
- 2.7 to 3.6 V<sub>CC</sub>
- Low Shutdown Current – 10 nA Typical
- Complete Shutdown – TXD, RXD, PIN Diode
- Three External Components
- Temperature Performance Guaranteed, -25°C to +85°C
- 25 mA LED Drive Current
- Integrated EMI Shield
- IEC825-1 Class 1 Eye Safe
- Edge Detection Input – Prevents the LED from Long Turn-On Time

#### Applications

- Mobile Telecom
  - Cellular Phones
  - Pagers
  - Smart Phones
- Data Communication
  - PDAs
  - Portable Printers
- Digital Imaging
  - Digital Cameras
  - Photo-Imaging Printers
- Electronic Wallet

#### Description

The HSDL-3200 is a new generation of low-cost Infrared (IR) transceiver module from Agilent Technologies. It features the smallest footprint in the industry at 2.5 H x 8.0 W x 3.0 D mm. The supply voltage can range from 2.7 V to 3.6 V. The LED drive current of 25 mA assures that link distances meet the IrDA Data 1.2 (low power) physical layer specification.

The HSDL-3200 meets the link distance of 20 cm to other low power devices, and 30 cm to standard 1 meter IrDA devices.

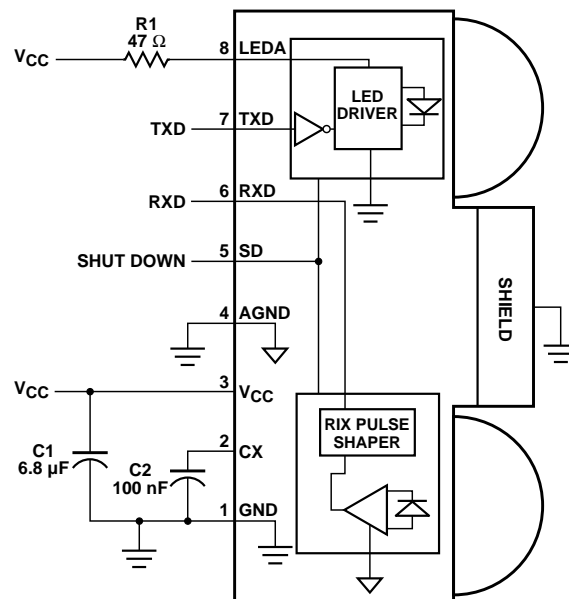
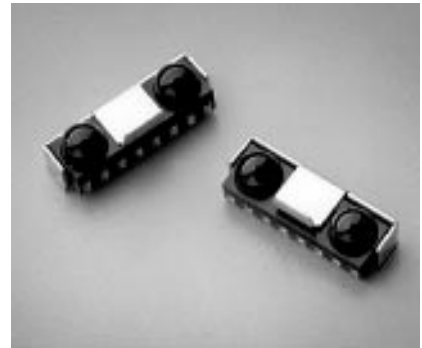

### I/O Pins Configuration Table

Pin	Description	Symbol	Active	Note
1	Ground	GND		
2	Pin Bypass Capacitor	CX		
3	Supply Voltage	V <sub>CC</sub>		
4	Analog Ground	AGND		
5	Shut Down	SD	High	1
6	Receiver Data Output	RXD	Low	
7	Transmitter Data Input	TXD	High	
8	LED Anode	LEDA		

**Note:**

1. The shutdown pin (SD) must be driven either high or low. Do NOT float the pin.

### Transceiver I/O Truth Table

Inputs			Outputs		Notes
TXD	Light Input to Receiver	SD	LED	RXD	
High	Don't Care	Low	On	Not Valid	
Low	High	Low	Off	Low	2, 3
Low	Low	Low	Off	High	
Don't Care	Don't Care	High	Off	High	

**Notes:**

2. In-Band IrDA signals and data rates  $\leq 115.2$  Kb/s.
3. RXD Logic Low is a pulsed response. The condition is maintained for a duration dependent on pattern and strength of the incident intensity.

### Recommended Application Circuit Components

Component	Recommended Value	Note
R1	47 $\Omega$ , $\pm 1\%$ , 0.125 Watt	
C1	6.8 $\mu$ F, $\pm 20\%$ , Tantalum	4
C2	100 nF, $\pm 20\%$ , X7R Ceramic	

**Note:**

4. C1 must be placed within 0.7 cm of the HSDL-3200 to obtain optimum noise immunity.

*Caution: The BiCMOS inherent to this design of this component increases the component's susceptibility to damage from electrostatic discharge (ESD). It is advised that normal static precautions be taken in handling and assembly of this component to prevent damage and/or degradation which may be induced by ESD.*

## Absolute Maximum Ratings

For implementations where case to ambient thermal resistance  $\leq 50^\circ\text{C/W}$ .

Parameter	Symbol	Min.	Max.	Units	Conditions
Storage Temperature	$T_S$	-40	100	$^\circ\text{C}$	
Operating Temperature	$T_A$	-25	85	$^\circ\text{C}$	
DC LED Current	$I_{\text{LED}}$ (DC)		20	mA	
Peak LED Current	$I_{\text{LED}}$ (PK)		80	mA	$\leq 90\ \mu\text{s}$ Pulse Width, $\leq 25\%$ Duty Cycle
LED Anode Voltage	$V_{\text{LEDA}}$	-0.5	7	V	
Supply Voltage	$V_{\text{CC}}$	0	7	V	
Input Voltage TXD, SD	$V_I$	0	$V_{\text{CC}} + 0.5$	V	
Output Voltage RXD	$V_O$	-0.5	$V_{\text{CC}} + 0.5$	V	

## Recommended Operating Conditions

Parameter	Symbol	Min.	Max.	Units	Conditions	Notes
Operating Temperature	$T_A$	-25	85	$^\circ\text{C}$		
Supply Voltage	$V_{\text{CC}}$	2.7	3.6	V		
Logic High Voltage TXD, SD	$V_{\text{IH}}$	$2/3 V_{\text{CC}}$	$V_{\text{CC}}$	V		
Logic Low Voltage TXD, SD	$V_{\text{IL}}$	0	$1/3 V_{\text{CC}}$	V		
Logic High Receiver Input Irradiance	$E_{\text{IH}}$	0.0081	500	$\text{mW}/\text{cm}^2$	For in-band signals.	5
Logic Low Receiver Input Irradiance	$E_{\text{IL}}$		0.3	$\mu\text{W}/\text{cm}^2$	For in-band signals.	5
LED Current Pulse Amplitude	$I_{\text{LEDA}}$	25	80	mA	Guaranteed at $25^\circ\text{C}$	
Receiver Signal Rate		2.4	115.2	Kb/s		
Ambient Light					See "Test Methods" on page 12 for details	

### Note:

- An in-band optical signal is a pulse/sequence where the peak wavelength,  $\lambda_p$ , is defined as  $850\ \text{nm} \leq \lambda_p \leq 900\ \text{nm}$ , and the pulse characteristics are compliant with the IrDA Serial Infrared Physical Layer Link Specification.

## Electrical and Optical Specifications

Specifications hold over the recommended operating conditions unless otherwise noted. Unspecified test conditions can be anywhere in their operating range. All typical values are at 25°C and 3.0 V unless otherwise noted.

Parameter		Symbol	Min.	Typ.	Max.	Units	Conditions	Note
<b>Receiver</b>								
RXD Output Voltage	Logic Low	$V_{OL}$	0		0.4	V	$I_{OL} = 200 \mu\text{A}$ , For in-band EI	6
	Logic High	$V_{OH}$	$V_{CC} - 0.2$		$V_{CC}$	V	$I_{OH} = -200 \mu\text{A}$ , For in-band EI $\leq 0.3 \mu\text{W}/\text{cm}^2$	
Viewing Angle		$2\phi_{1/2}$	30			°		
Peak Sensitivity Wavelength		$\lambda_p$		880		nm		
RXD Pulse Width		tpw	1.5	2.5	4.0	$\mu\text{s}$		6
RXD Rise and Fall Times		tr, tf		25	100	ns	tpw (EI) = 1.6 $\mu\text{s}$ , $C_L = 10 \text{ pF}$	
Receiver Latency Time		$t_L$		25	50	$\mu\text{s}$		6
Receiver Wake Up Time		tw		50	100	$\mu\text{s}$		7
<b>Transmitter</b>								
Radiant Intensity		$E_{IH}$	4	8	28.8	mW/Sr	$I_{LEDA} = 25 \text{ mA}$ , $T_A = 25^\circ\text{C}$ , $\theta_{1/2} \leq 15^\circ$	
Peak Wavelength		$\lambda_p$		875		nm		
Spectral Line Half Width		$\Delta\lambda_{1/2}$		35		nm		
Viewing Angle		$2\theta_{1/2}$	30		60	°		
Optical Pulse Width		tpw	1.5	1.6	2	$\mu\text{s}$	tpw (TXD) = 1.6 $\mu\text{s}$	
Optical Rise and Fall Times		tr (EI) tf (EI)			600	ns	tpw (TXD) = 1.6 $\mu\text{s}$	
Maximum Optical Pulse Width		tpw (max)		20	50	$\mu\text{s}$	TXD pin stuck high	
LED Anode On State Voltage		$V_{ON}$ (LEDA)			1.6	V	$I_{LEDA} = 25 \text{ mA}$ , $V_{IH}$ (TXD) = 2.7 V	
LED Anode Off State Leakage		$I_{LK}$ (LEDA)		0.01	1.0	$\mu\text{A}$	$V_{LEDA} = V_{CC} = 3.6 \text{ V}$ , $V_I$ (TXD) $\leq 1/3 V_{CC}$	
<b>Transceiver</b>								
TXD and SD Input Current	Logic Low	$I_L$	-1	-0.01	1	$\mu\text{A}$	$0 \leq V_I \leq 1/3 V_{CC}$	
	Logic High	$I_H$		0.01	1	$\mu\text{A}$	$V_I \geq 2/3 V_{CC}$	
Supply Current	Shutdown	$I_{CC1}$		10	200	nA	$V_{CC} = 3.6 \text{ V}$ , $V_{SD} \geq V_{CC} - 0.5$	
	Idle	$I_{CC2}$		2.5	4	mA	$V_{CC} = 3.6 \text{ V}$ , $V_I$ (TXD) $\leq 1/3 V_{CC}$ , EI = 0	
	Active Receiver	$I_{CC3}$		2.6	5	mA	$V_{CC} = 3.6 \text{ V}$ , $V_I$ (TXD) $\leq 1/3 V_{CC}$	8, 9

### Notes:

- For in-band signals  $\leq 115.2 \text{ Kb/s}$  where  $8.1 \mu\text{W}/\text{cm}^2 \leq EI \leq 500 \text{ mW}/\text{cm}^2$ .
- Wake up time is measured from SD pin high to low transition or  $V_{CC}$  power on to valid RXD output.
- Typical value is at EI = 10  $\text{mW}/\text{cm}^2$ .
- Maximum value is at EI = 500  $\text{mW}/\text{cm}^2$ .

### Package Outline with Dimensions for Recommended PC Board Pad Layout

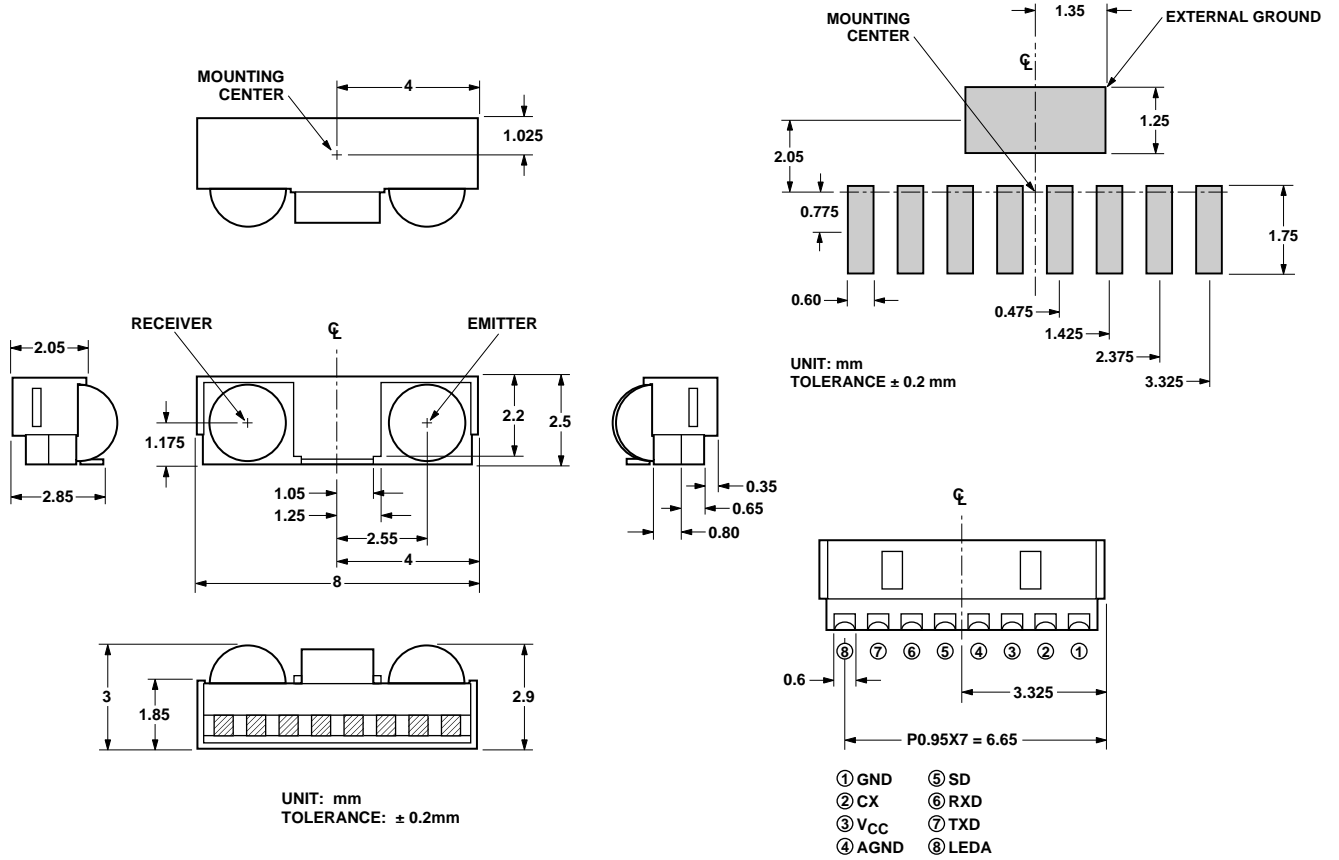

### Tape and Reel Dimensions

UNIT: mm

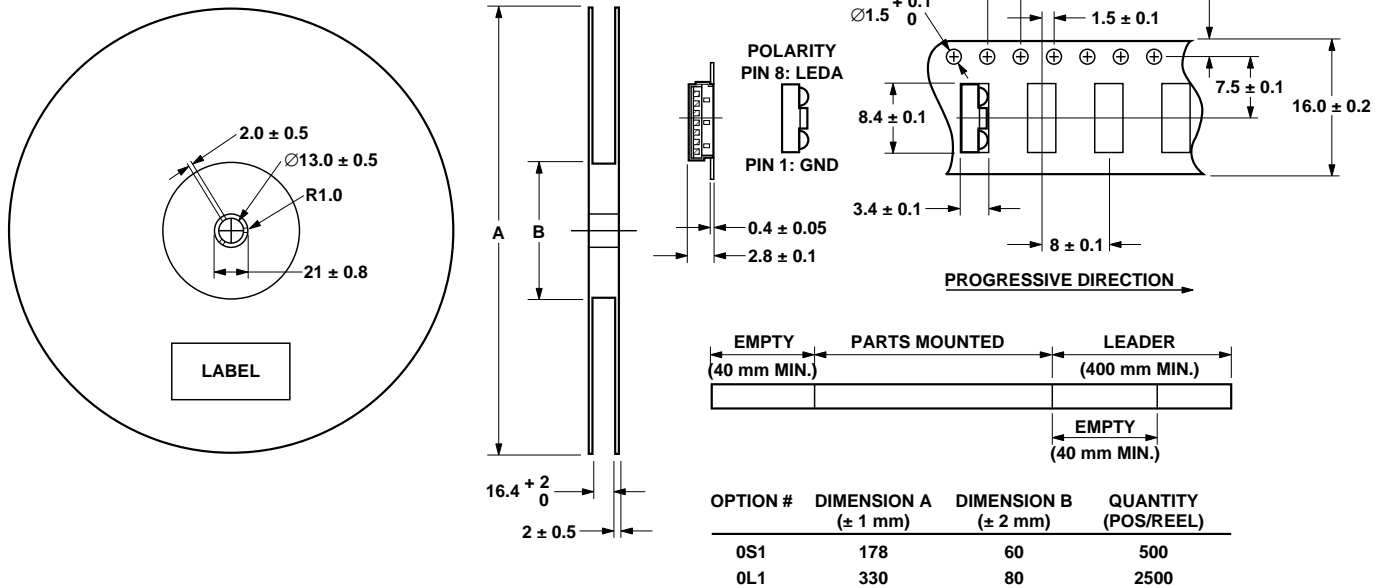

## Reflow Profile

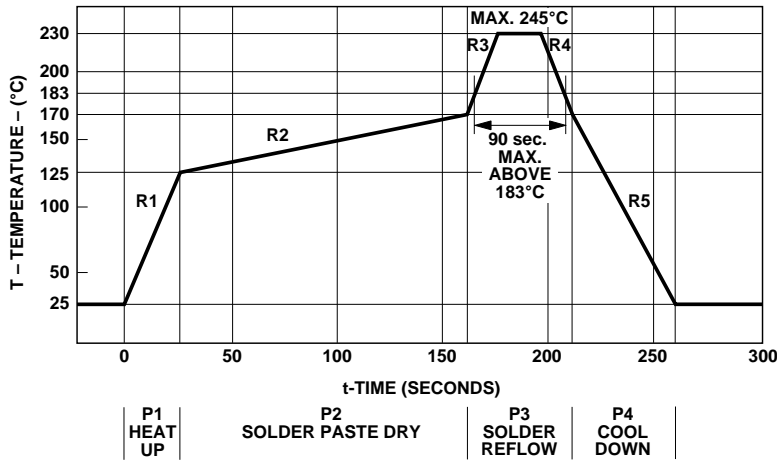

PROCESS ZONE	SYMBOL	$\Delta T$	MAXIMUM $\Delta T/\Delta TIME$
HEAT UP	P1, R1	25°C TO 125°C	4°C/s
SOLDER PASTE DRY	P2, R2	125°C TO 170°C	0.5°C/s
SOLDER REFLOW	P3, R3 P3, R4	170°C TO 230°C (245°C MAX.) 230°C TO 170°C	4°C/s -4°C/s
COOL DOWN	P4, R5	170°C TO 25°C	-3°C/s

The reflow profile is a straight line representation of a nominal temperature profile for a convective reflow solder process. The temperature profile is divided into four process zones, each with different  $\Delta T/\Delta time$  temperature change rates. The  $\Delta T/\Delta time$  rates are detailed in the above table. The temperatures are measured at the component to printed circuit board connections.

In **process zone P1**, the PC board and HSDL-3200 castellation I/O pins are heated to a temperature of 125°C to activate the flux in the solder paste. The temperature ramp up rate, R1, is limited to 4°C per second to allow for even heating of both the PC board and HSDL-3200 castellation I/O pins.

**Process zone P2** should be of sufficient time duration (> 60 seconds) to dry the solder paste. The temperature is raised to a level just below the liquidus point of the solder, usually 170°C (338°F).

**Process zone P3** is the solder reflow zone. In zone P3, the temperature is quickly raised above the liquidus point of solder to 230°C (446°F) for optimum results. The dwell time above the liquidus point of solder should be between 15 and 90 seconds. It usually takes about 15 seconds to assure proper coalescing of the solder balls into liquid solder and the formation of good solder connections. Beyond a dwell time of 90 seconds, the intermetallic growth within the solder

connections becomes excessive, resulting in the formation of weak and unreliable connections. The temperature is then rapidly reduced to a point below the solidus temperature of the solder, usually 170°C (338°F), to allow the solder within the connections to freeze solid.

**Process zone P4** is the cool down after solder freeze. The cool down rate, R5, from the liquidus point of the solder to 25°C (77°F) should not exceed 3°C per second maximum. This limitation is necessary to allow the PC board and HSDL-3200 castellation I/O pins to change dimensions evenly, putting minimal stresses on the HSDL-3200 transceiver.

### Moisture Proof Packaging

The HSDL-3200 is shipped in moisture proof packaging. Once opened, moisture absorption begins.

### Recommended Storage Conditions

Storage Temperature	10°C to 30°C
Relative Humidity	below 60%

### Time from Unsealing to Soldering

After removal from the bag, the parts should be soldered within 2 days if stored at the recommended storage conditions. If times longer than 2 days are needed, the parts must be stored in a dry box.

### Baking

If the parts are not stored in dry conditions, they must be baked before reflow to prevent damage to the parts.

In Reels	60°C, t ≥ 48 hours
In Bulk	100°C, t ≥ 4 hours
	125°C, T ≥ 2 hours
	150°C, T ≥ 1 hour

Baking should only be done once.

### Solder Pad, Mask and Metal Stencil

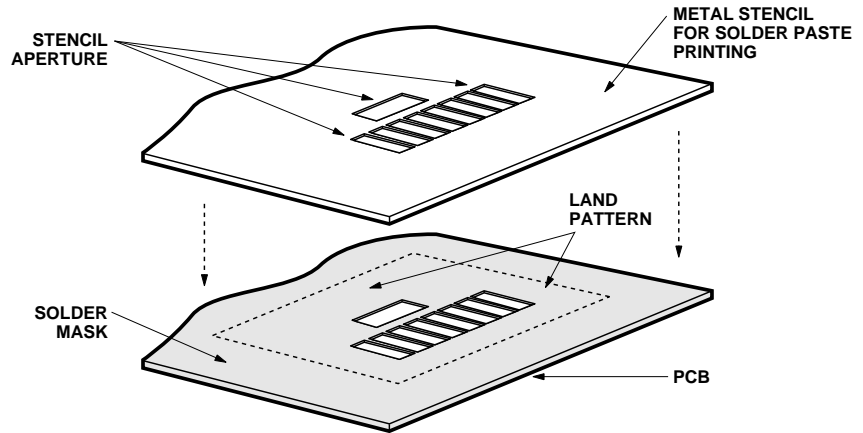

### Recommended Land Pattern

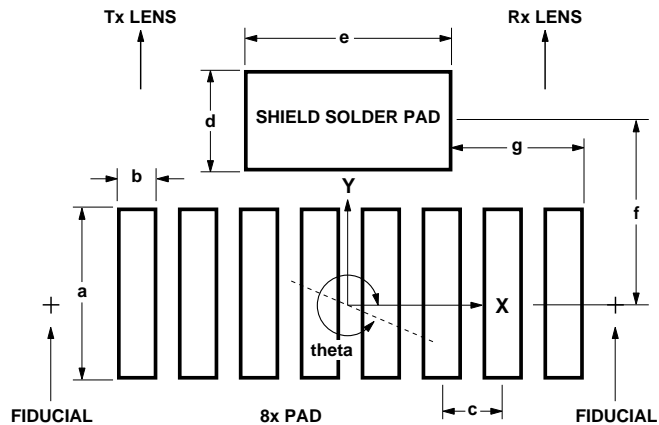

DIMENSION	mm	INCHES
a	1.75	0.069
b	0.60	0.024
c (PITCH)	0.95	0.037
d	1.25	0.049
e	2.70	0.106
f	2.20	0.087
g	2.28	0.089



## Recommended Metal Solder Stencil Aperture

It is recommended that only 0.152 mm (0.006 inches) or 0.127 mm (0.005 inches) thick stencil be used for solder paste printing. This is to ensure adequate printed solder paste volume and no shorting. The following combination of metal stencil aperture and metal stencil thickness should be used:

w, the width of aperture is fixed at 0.55 mm (0.022 inches).

Aperture opening for shield pad is 2.7 mm x 1.25 mm as per land.

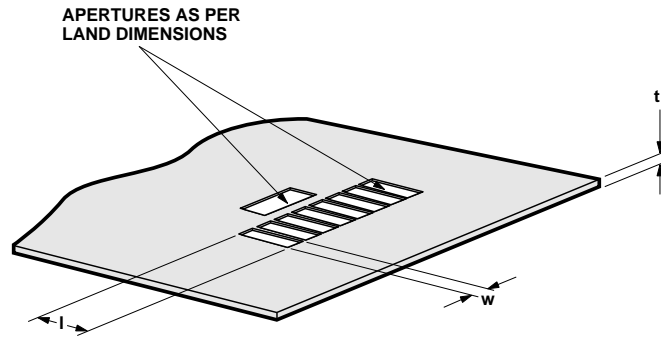

t, nominal stencil thickness		l, length of aperture	
mm	inches	mm	inches
0.152	0.006	2.60 ± 0.05	0.102 ± 0.002
0.127	0.005	3.00 ± 0.05	0.118 ± 0.002

## Adjacent Land Keepout and Solder Mask Areas

Adjacent land keep-out is the **maximum space** occupied by the unit relative to the land pattern. There should be no other SMD components within this area.

“h” is the minimum solder resist strip width required to avoid solder bridging adjacent pads.

It is recommended that two fiducial crosses be placed at mid-length of the pads for unit alignment.

**Note:** Wet/Liquid Photo-Imageable solder resist/mask is recommended.

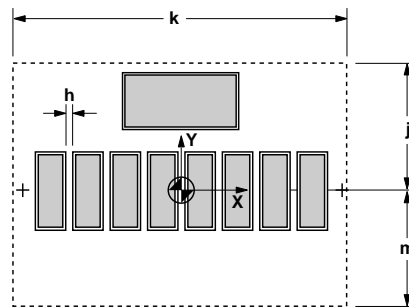

DIMENSION	mm	INCHES
h	MIN. 0.2	MIN. 0.008
k	8.2	0.323
j	2.6	0.102
m	3.0	0.118

## Recommended Solder Paste/Cream Volume for Castellations Joints

Based on calculation and experiment, the printed solder paste volume required per castellation pad is **0.22 cubic mm** (based on either no-clean or aqueous solder cream types with typically 60% to 65% solid content by volume). Using the recommended stencil will result in this volume of solder paste.

### Pick and Place Misalignment Tolerance and Self-Alignment after Solder Reflow

If the printed solder paste volume is adequate, the **HSDL-3200 will self-align** after solder reflow. Units should be properly reflowed in IR/Hot Air convection oven using the recommended reflow profile. The direction of board travel does not matter.

### Allowable Misalignment

Direction	Tolerance
<b>x</b>	$\leq 0.2$ mm (0.008 inches)
<b>Theta</b>	$\pm 3$ degrees

### Tolerance for X-Axis Alignment of Castellations

Misalignment of castellations to the land pad should not exceed 0.2 mm (0.008 in.), or about one half the width of the castellations during placement of the unit. The castellations will self-align to the pads during solder reflow.

### Tolerance for Rotational (Theta) Misalignment

Units when mounted should not be rotated more than  $\pm 3$  degrees with reference to center X-Y as shown in the recommended land pattern. Units with rotational misalignment of more than  $\pm 3$  degrees will not completely self-align after reflow. Units with less than a  $\pm 3$  degree misalignment will self-align after solder reflow.

### Y-Axis Misalignment of Castellations

In the Y direction, the HSDL-3200 does not self-align after solder reflow. It is recommended that it be placed in line with the fiducial mark (mid-length of land pad). This will enable sufficient land length (minimum of 1/2 land length) to form a good joint. See the drawing below.

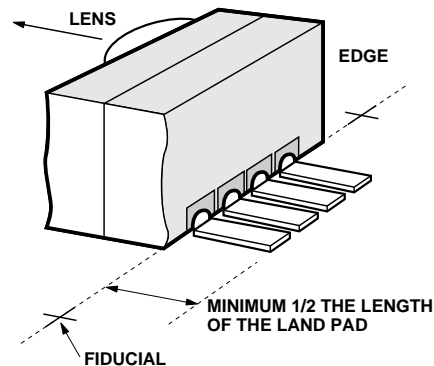

### Marking Information

The unit is marked with the datecode "YYWW" on the shield. YY is the year, and WW is the workweek.

### Ordering Information

Specify the part number followed by an option number.

HSDL-3200 #XXX

There are three options available:

<b>011</b>	Taped in a short strip (no reel), 10 per strip
<b>001</b>	Taped and 7" Reel packaging, 500 per reel
<b>021</b>	Taped and 13" Reel Packaging, 2500 per reel

## Window Design

To insure IrDA compliance, there are some constraints on the height and width of the optical window. The minimum dimensions ensure that the IrDA cone angles are met, and there is no vignetting, and the maximum dimensions ensure that the effects of stray light are minimized. The minimum size corresponds to a cone angle of 30 degrees, the maximum to a cone angle of 60 degrees.

The drawing below shows the module positioned in front of a window.

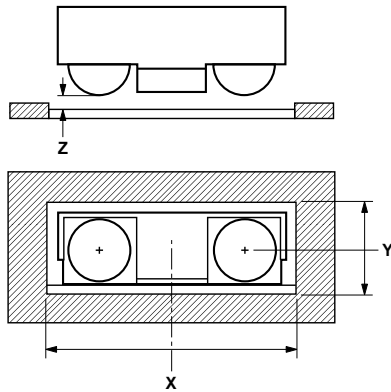

X is the width of the window, Y is the height of the window, and Z is the distance from the HSDL-3200 to the back of the window.

The distance from the center of the LED lens to the center of the photodiode lens is 5.1 mm.

The equations that determine the size of the window are as follows:

$$X = 5.1 + 2(Z + D) \tan \theta$$

$$Y = 2(Z + D) \tan \theta$$

Where  $\theta$  is the required half angle for viewing. For the IrDA minimum, it is 15 degrees, for the IrDA maximum it is 30 degrees. (D is the depth of the LED image inside the part, 3.17 mm.) These equations result in the following tables and graphs:

## Minimum and Maximum Window Sizes

Dimensions are in mm.

Depth (Z)	Y Min.	X Min.	Y Max.	X Max.
0	1.70	6.80	3.66	8.76
1	2.23	7.33	4.82	9.92
2	2.77	7.87	5.97	11.07
3	3.31	8.41	7.12	12.22
4	3.84	8.94	8.28	13.38
5	4.38	9.48	9.43	14.53
6	4.91	10.01	10.59	15.69
7	5.45	10.55	11.74	16.84
8	5.99	11.09	12.90	18.00
9	6.52	11.62	14.05	19.15
10	7.06	12.16	15.21	20.31

## Window Height Y vs. Module Depth Z

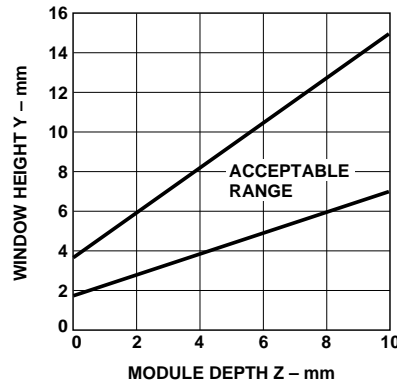

## Window Width X vs. Module Depth Z

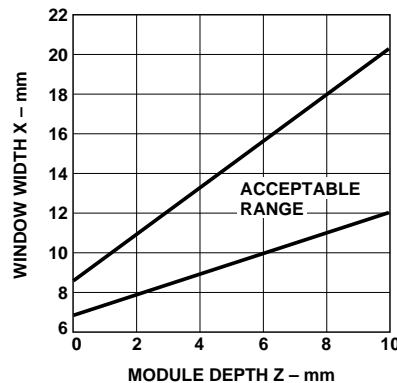

### Shape of the Window

From an optics standpoint, the window should be flat. This ensures that the window will not alter either the radiation pattern of the LED, or the receive pattern of the photodiode.

If the window must be curved for mechanical design reasons, place a curve on the back side of the window that has the same radius as the front side. While this will not completely eliminate the lens effect of the front curved surface, it will reduce the effects. The amount of change in the radiation pattern is dependent upon the material chosen for the window, the radius of the front and back curves, and the distance from the back surface to the transceiver. Once these items are known, a lens design can be made which will eliminate the effect of the front surface curve.

The following drawings show the effects of a curved window on the radiation pattern. In all cases, the center thickness of the window is 1.5 mm, the window is made of polycarbonate plastic, and the distance from the transceiver to the back surface of the window is 3 mm.

### Flat Window

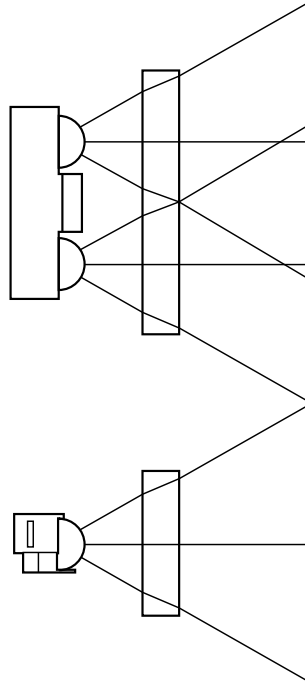

### Curved Front and Back

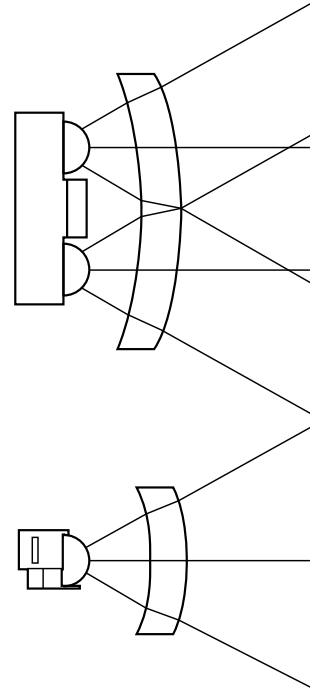

### Curved Front, Flat Back

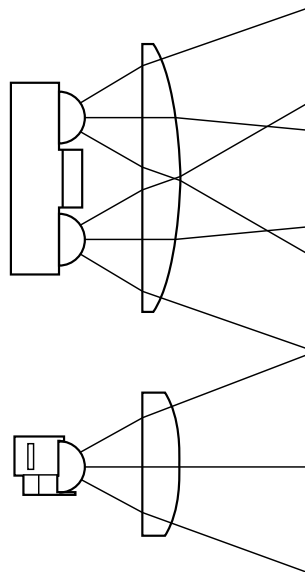

## Test Methods

### Background Light and Electromagnetic Field

There are four ambient interference conditions in which the receiver is to operate correctly. The conditions are to be applied separately:

1. Electromagnetic field:  
3 V/m maximum (please refer to IEC 801-3, severity level 3 for details).
2. Sunlight:  
10 kilolux maximum at the optical port. This is simulated with an IR source having a peak wavelength within the range of 850 nm to 900 nm and a spectral width of less than 50 nm biased to provide  $490 \mu\text{W}/\text{cm}^2$  (with no modulation) at the optical port. The light source faces the optical port.

This simulates sunlight within the IrDA spectral range. The effect of longer wavelength radiation is covered by the incandescent condition.

3. Incandescent Lighting:  
1000 lux maximum. This is produced with general service, tungsten-filament, gas-filled, inside frosted lamps in the 60 Watt to 100 Watt range to generate 1000 lux over the horizontal surface on which the equipment under test rests. The light sources are above the test area. The source is expected to have a filament temperature in the 2700 to 3050 Kelvin range and a spectral peak in the 850 to 1050 nm range.
4. Fluorescent Lighting:  
1000 lux maximum. This is simulated with an IR source having a peak wavelength within the range of 850 nm to 900 nm and a spectral width of less than 50 nm biased and modulated to provide an optical square wave signal ( $0 \mu\text{W}/\text{cm}^2$  minimum and  $0.3 \mu\text{W}/\text{cm}^2$  peak amplitude with 10% to 90% rise and fall times less than or equal to 100 ns) over the horizontal

surface on which the equipment under test rests. The light sources are above the test area. The frequency of the optical signal is swept over the frequency range from 20 kHz to 200 kHz.

Due to the variety of fluorescent lamps and the range of IR emissions, this condition is not expected to cover all circumstances. It will provide a common floor for IrDA operation.