

Description

The MIM-5xxBK2 is miniaturized infrared receivers for remote control and other applications requiring improved ambient light rejection. The separate PIN diode and preamplifier IC are assembled on a single leadframe. The epoxy package contains a special IR filter. This module has excellent performance even in disturbed ambient light applications and provides protection against uncontrolled output pulses.

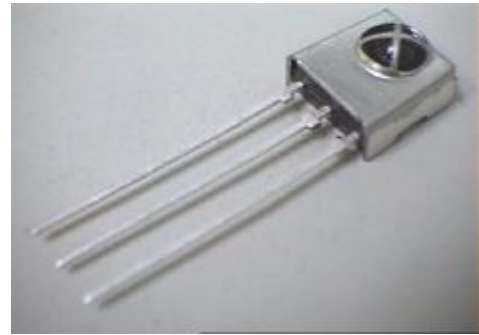

Features

- Photo detector and preamplifier in one package
- Internal filter for PCM frequency
- High immunity against ambient light
- Improved shielding against electric field disturbance
- 5.0-Volt supply voltage; low power consumption
- TTL and CMOS compatibility

MIM-5xxBK2 Series Models

- MIM-530BK2 30.0KHz
- MIM-533BK2 33.0KHz
- MIM-536BK2 36.0KHz
- MIM-537BK2 36.7KHz
- MIM-538BK2 38.0KHz
- MIM-540BK2 40.0KHz
- MIM-544BK2 44.0KHz
- MIM-556BK2 56.0KHz

BLOCK DIAGRAM

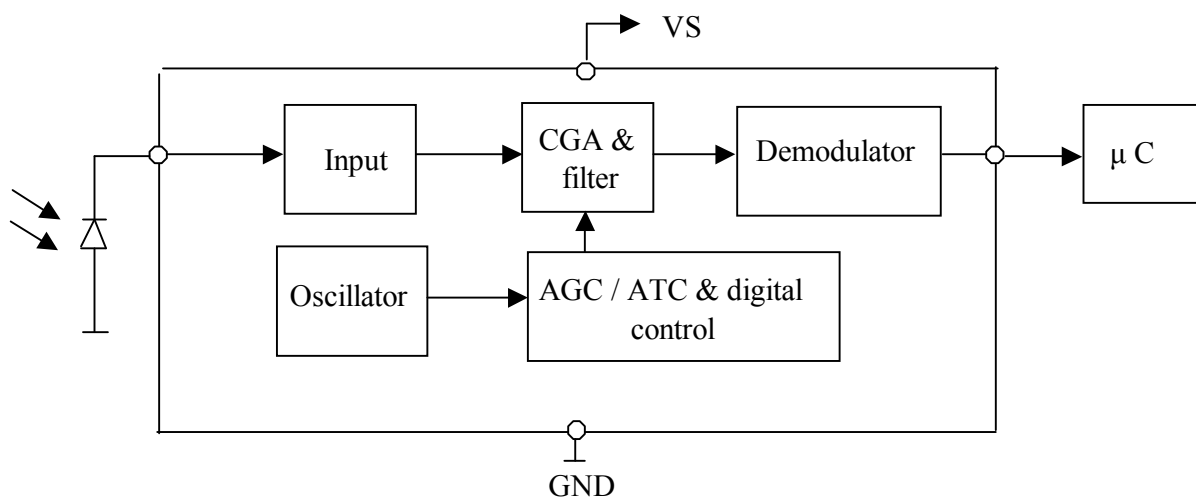

Absolute Maximum Ratings

@ Ta=25°C

Item	Symbol	Ratings	Unit	Remark
Supply voltage	V _{CC}	-0.3 ~ 6.0	V	
Supply Current	I _s	5.0	mA	
Operating temperature	T _{opr}	-25 ~ + 85	°C	
Storage temperature	T _{stg}	-25 ~ + 85	°C	
Soldering temperature	T _{sd}	260	°C	t ≤ 5 s, 1mm from case
Power dissipation at Ta=25oC	P _{tot}	30	mW	

Electro-optical characteristics (V_{CC}=5.0V)

Parameter	Symbol	Min.	Typ.	Max.	Unit	Remarks
Supply Voltage	V _s	4.5	5.0	5.5	V	
Current consumption	I _{cc}		1.4	2.0	mA	Under no signal
Response wavelength	λ _p		940		nm	
Output form	----- active low output -----					
H level output voltage	V _{oh}	4.2			V	
L level output voltage	V _{ol}			0.5	V	
H level output pulse width	T _{wh}	400		800	μs	
L level output pulse width	T _{wl}	400		800	μs	
Distance between emitter & detector	L ₁	10.0			m	Note 1
Half angle	Δθ		±45		deg	Horizontal direction

Test Method

A. Standard Transmitter

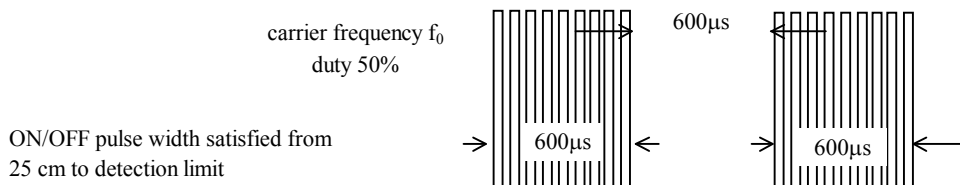

Fig 1. Burst Wave

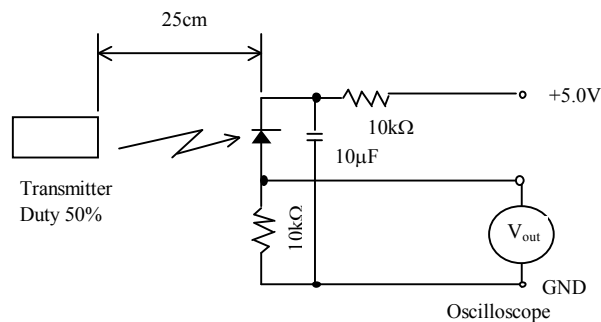
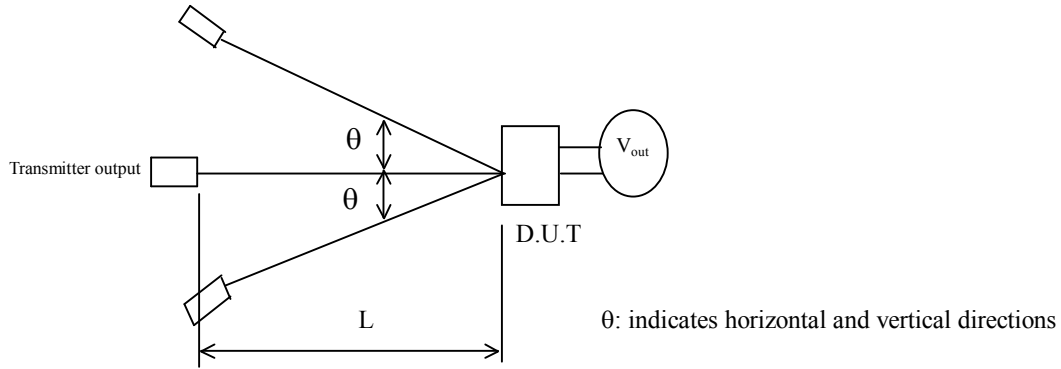
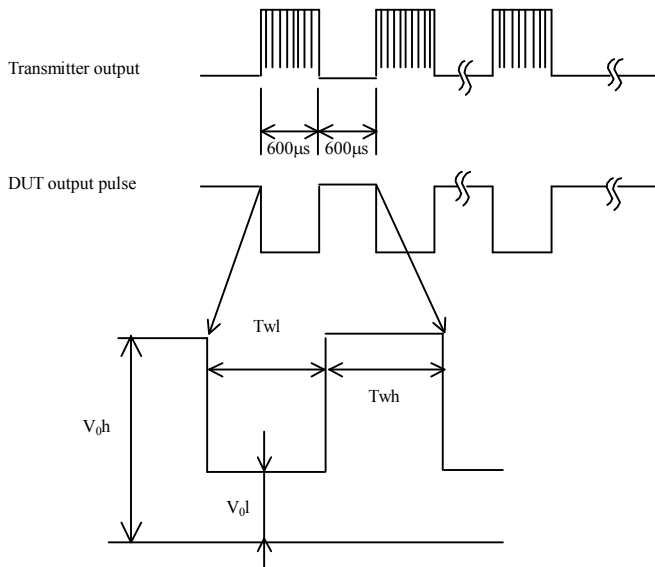

Fig 2. Standard Transmitter Measurement circuit

B. Detection Length Test



C . Pulse Width Test



Application Circuit

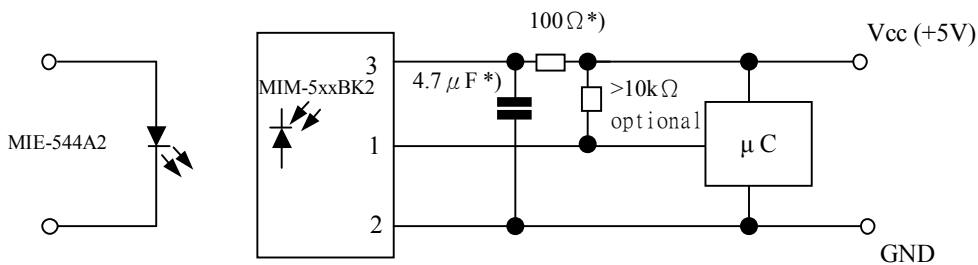

*) recommended to suppress power supply disturbances

Dimensions in mm

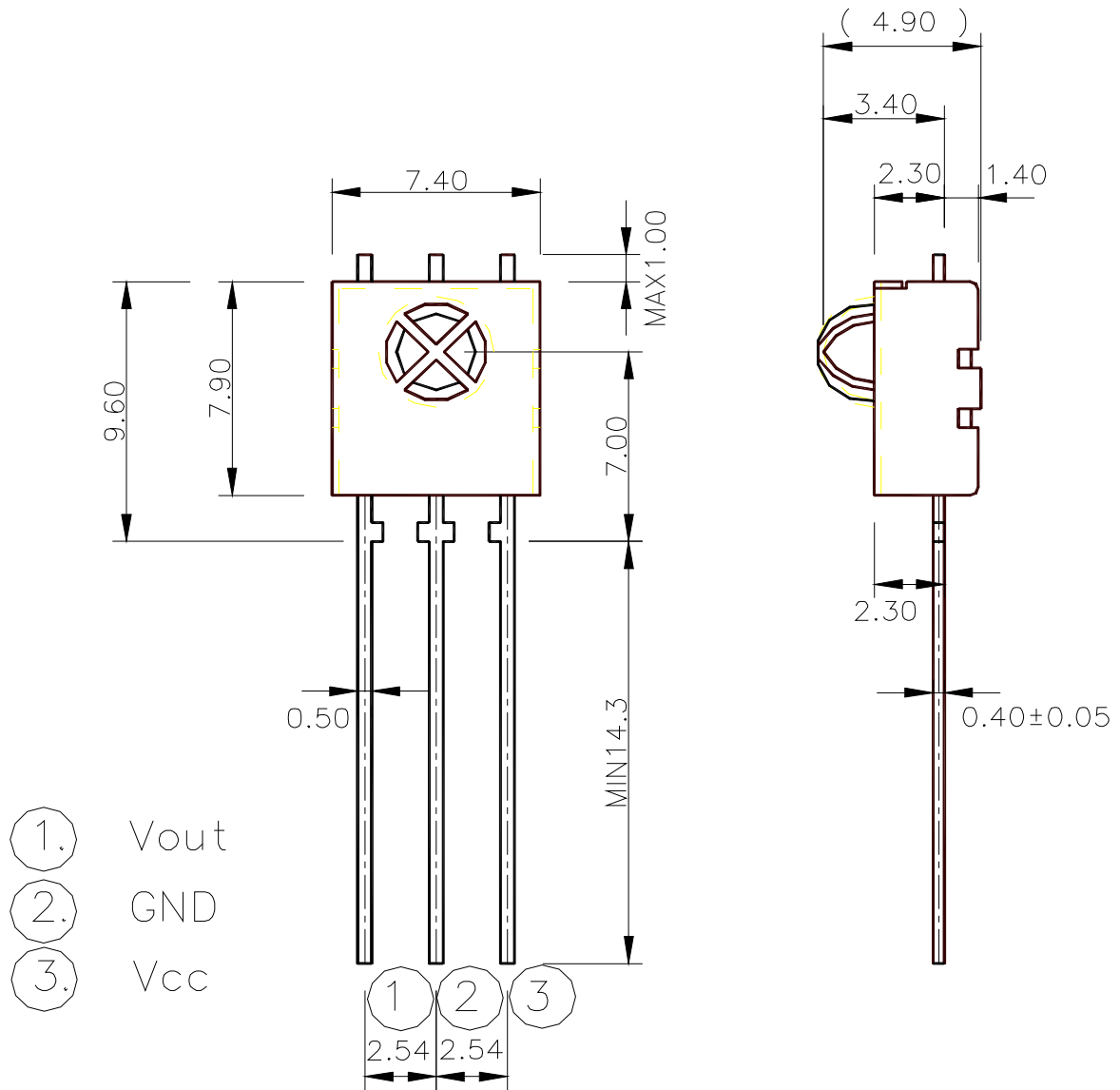

Ps 1. TOLERANCE : ±0.30 UNLESS OTHERWISE SPECIFIED

CHARACTERISTIC CURVES (T_A=25°C)

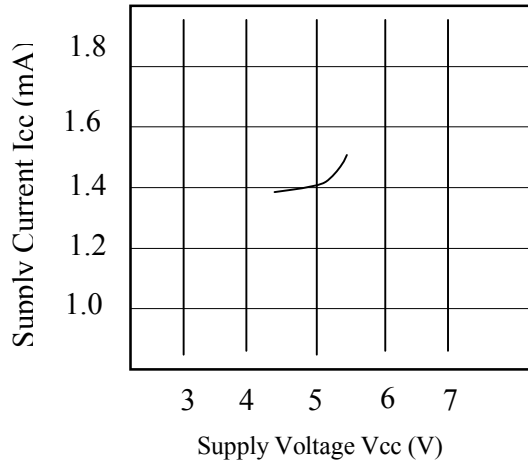

SUPPLY VOLTAGE vs. SUPPLY CURRENT

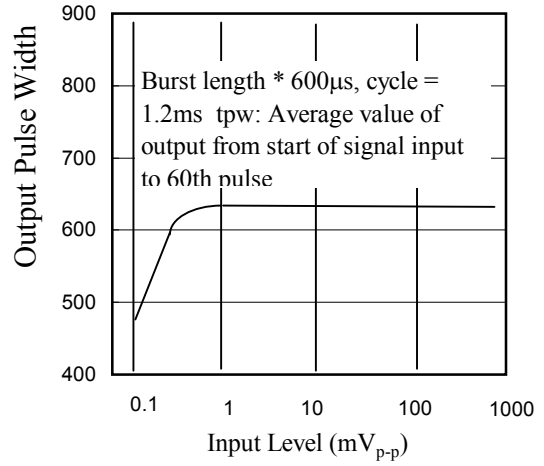

INPUT LEVEL vs. OUTPUT PULSE WIDTH

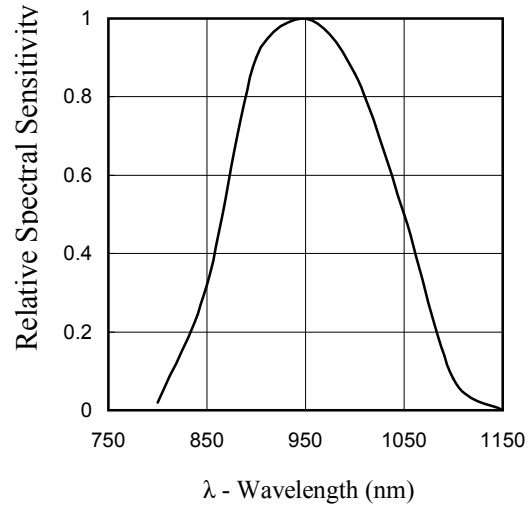
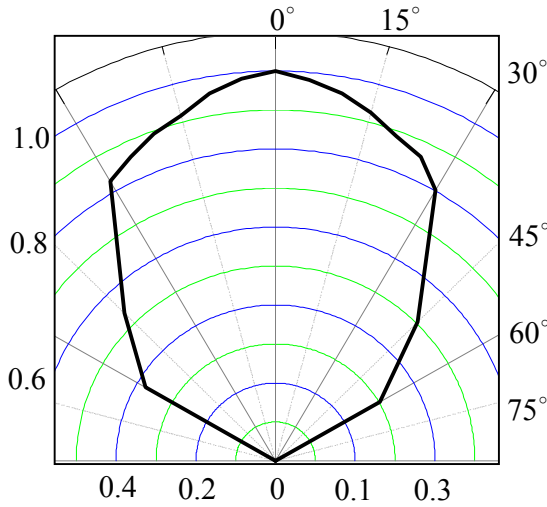

RELATIVE SPECTRAL SENSITIVITY vs WAVELENGTH

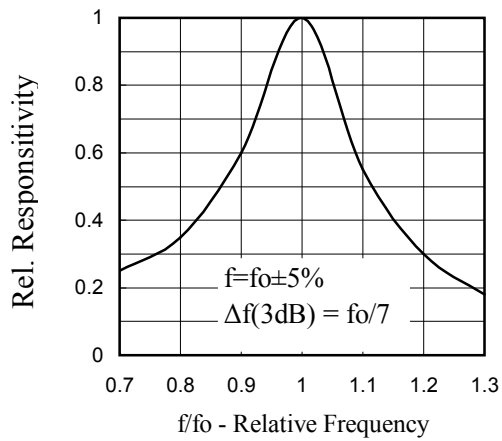

FREQUENCY DEPENDENCE OF RESPONSIVITY

Reliability

Test item	Test condition	Standard
High temperature	Ta=+80°C t=240H	Note 2.
High temp. & high humi.	Ta=+40°C 90%RH t=240H	Note 2.
Low temperature	Ta= -30°C t=240H	Note 2.
Temperature cycle	-30°C(0.5H) ~ +80°C(0.5H) 20cycle	Note 2.
Dropping	Test devices shall be dropped 3 times naturally onto hard wooden board from a 75cm height position.	Note 3.

NOTE 1. Distance between emitter & detector specifies maximum distance that output wave form satisfies the standard under the conditions below against the standard transmitter.

- (1) Measuring placeIndoor without extreme reflection of light.
- (2) Ambient light source... Detecting surface illumination shall be 200±50Lux under ordinary hite fluorescense lamp of no high frequency lighting.
- (3) Standard transmitter ... Burst wave indicated in Fig 1. of standard transmitter shall be arranged to 50mVp-p under the measuring circuit specified in Fig 2.

NOTE 2. (electro-optical characteristics) shall be satisfied after leaving 2 hours in the normal temperature .

NOTE 3. (electro-optical characteristics) shall be satisfied and no conoid deforms and destructions of appearance .(excepting deforms of terminals)

Inspection standard

1. Among electrical characteristics , total number shall be inspected on items blow.
 - 1-1 front distance between emitter & detector
 - 1-2 Current consumption
 - 1-3 H level output voltage
 - 1-4 L level output voltage
2. Items except above mentioned are not inspected particularly , but shall fully satisfy

CAUTION (When use and storage of this device)

1. Store and use where there is no force causing transformation or change in quality .
2. Store and use where there is no corrosive gas or sea(salt) breeze .
3. Store and use where there is no extreme humidity .
4. Solder the lead-pin within the condition of ratings. After soldering do not add extra force .
5. Do not wash this device . Wipe the stains of diode side with a soft cloth. You can use the solvent , ethylalcohol or methylalcohol or isopropylene only .
6. To prevent static electricity damage to the Pre-AMP make sure that the human body , the soldering iron is connected to ground before using .
7. Put decoupling device between Vcc and GND for reduce the noise from power supply line .
8. The performance of remote-control system depends on environments condition and ability of periferal parts. Customer should evaluate the performance as total system in those conditions after system up with components such as commander , micon and this receiver module .

Others

1. This device is not design to endure radiative rays and heavily charged particles .
2. In case where any trouble or questions arise, both parties agree to make full discussion covering the said problem .