



Technical Data Sheet

Infrared Data Transceiver Module

Preliminary

TM3201/TR2

Features

- Excellent Fluorescent noise immunity and very high EMI immunity
- Wide Operating Voltage Range from 2.0 to 5.5 Volts
- IrED Operating Voltage Range from 2.0 to $V_{cc}+4$ Volts
- Ultra Small Surface Mount Package:
 - L8.0mm * W3.0mm * H2.5mm
- 2.4kbps to 115.2kbps data rates IrDA compliant
- Programmable current limit transmitter:
 - Low 30mA & 50us pulse width limiting
- Few External Components Required



Descriptions

The TM3201/TR2 is a new generation of low cost, multi-mode IrDA module in ultra small surface mount package. The operating voltage can range from 2.0 to 5.5 Volts and independent IrED supply voltage can arrive $V_{cc}+4$ Volts. This module supports data rates speed up to 115.2kbps and compliant to the IrDA 1.3. At low power mode, a V_{cc} bypass capacitor is the only external component required.

Applications

- Cellular Phones, Pagers, Smart Phones
- PDA, Printers
- Digital Still and Video Cameras
- PCs

Device NO:DTM-321-001

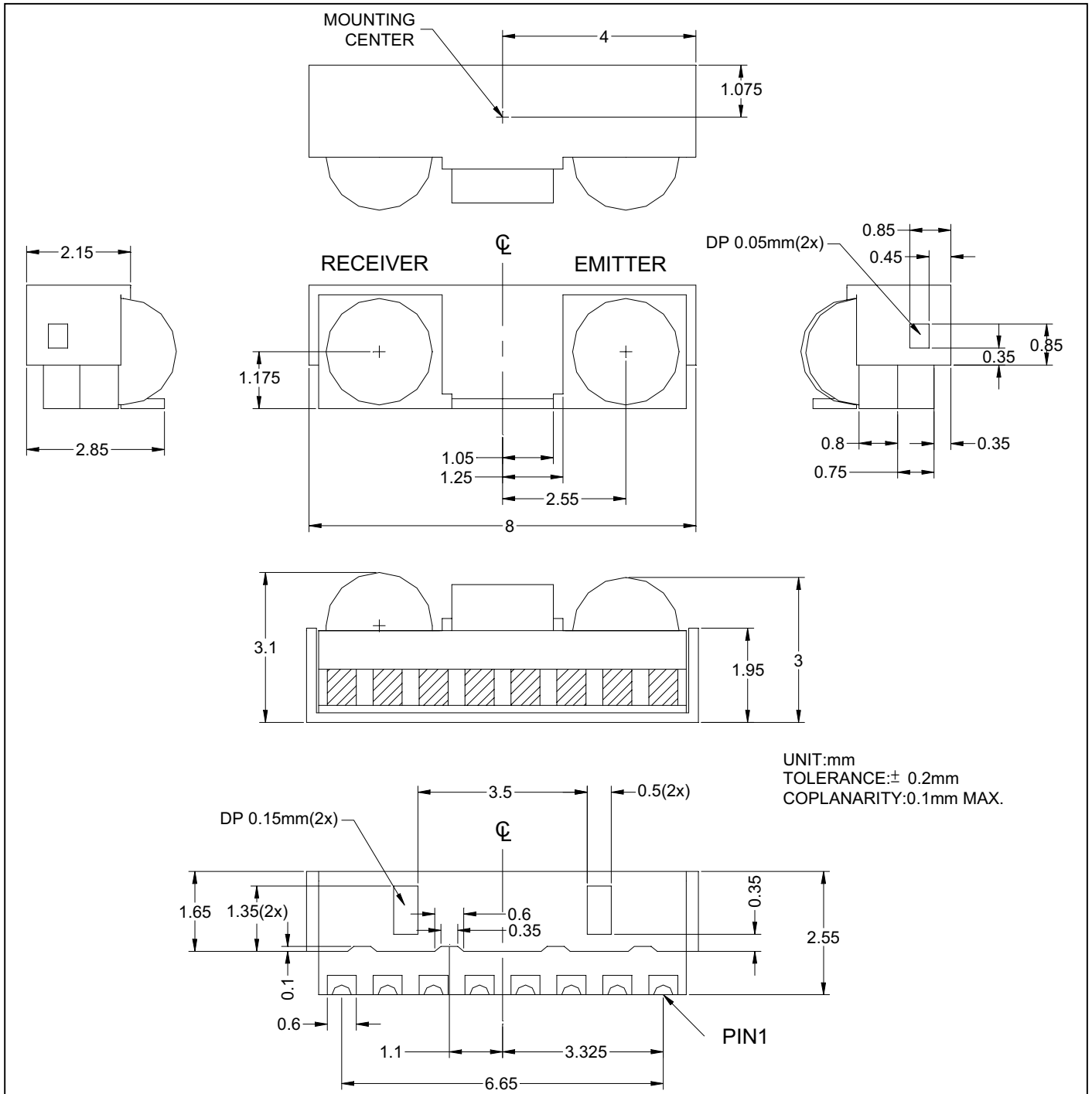
Package Dimensions

Device Selection Guide

Mode	Low Power		Standard		λ p	Operating Voltage (Vcc)	Data Rate
	Link Distance	Angle 2θ 1/2	Link Distance	Angle 2θ 1/2			
Low Power TM3201/TR2	>20cm	+/-15 +/-30	>30cm	+/-15 +/-30	850~900 nm	2.0~5.5 Volts	2.4~115.2 kbps

Functional Block Diagram

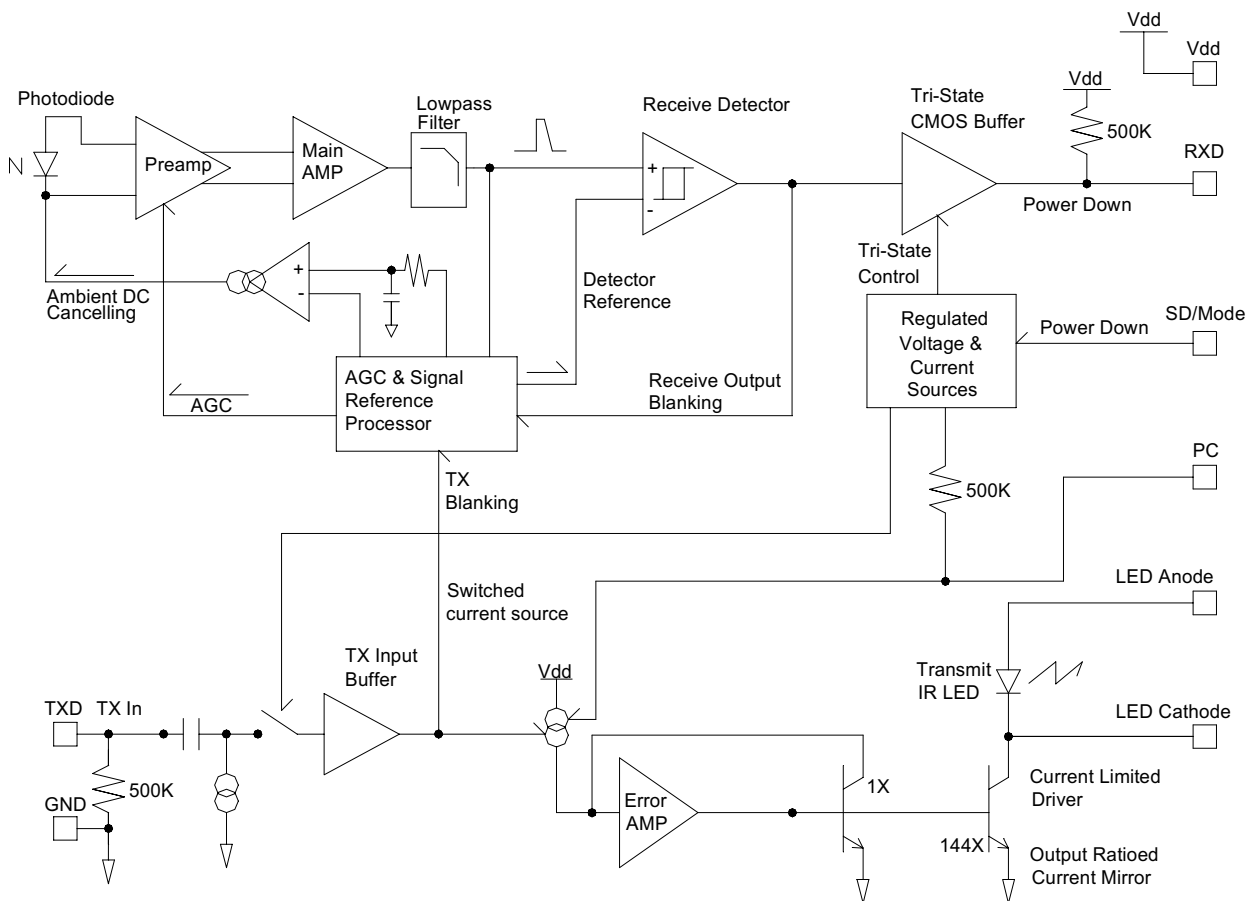

Pin Descriptions

Pin	Symbol	Function	Description	I/O	Active
1	GND	Ground	Connect to system ground		
2	NC	No Connect			
3	Vcc	Supply Voltage	Supply Voltage from 2.0 to 5.5 Volts. *Note 1		
4	AGND	Analog Ground	Connect to a “quiet” ground.		
5	SD	Shut Down	Must be driven either high or low. *Note 2		
6	RXD	Receiver Data Output	Output is a low pulse when a light pulse is seen. *Note 3	O	Low
7	TXD	Transmitter Data Input	Logic High turn on the IrED. *Note 4	I	High
8	V _{LEDA}	IrED Supply Voltage	IrED Supply Voltage from 2.0 to Vcc+4 Volts. *Note 5		

Note 1: Receives power supply from 2.0 to 5.5 Volts. This pin provides power for the receiver and transmitter drive section. Power supply noise in 100KHz to 2MHz range must have a dv/dt of less than 50mV/us in receive mode.

Note 2: Asserting this pin above 1.4V causes the device to shut down, disabling transmitter and tri-stating the receiver output; however, it must be driven above Vdd-0.7V for shutdown current consumption to be less 1uA. Power up receiver latency (time to come to full sensitivity) is < 100us. Enabling this pin (asserting logic low) will also clock the TXI input into the TX power mode control D flip flop.

Note 3: Normally high goes low for duration of receive pulse. Output is a CMOS driver providing rail to rail operation. RXD may go low continuously if the DC ambient exceeds input capacity. During shutdown RXD output tri-states with a weak (500K) pull up.

Note 4: Asserting this pin above 1.4V turns on transmitter. This input is gated by the shutdown function and AC coupled. Maximum transmit pulse width is ~50usec. Input has 500K pull down which is active even during shutdown.

Note 5: V_{LEDA}=9.0V(Max.) in standby mode

Absolute Maximum Ratings (Ta=25°C) reference point Pin GND unless otherwise noted.

Typical values are for DESIGN AID ONLY, not guaranteed nor subject to production testing.

Parameters	Test Conditions	Symbol	Min.	Typ.	Max.	Unit
Supply Voltage	All States	V _{cc}	-0.5		7	V
IrED Supply Voltage	SD=0, TXD=V _{cc}	V _{LEDA}	-0.5		V _{cc} +4	V
	V _{cc} =0~7V, TXD=0	V _{LEDA}	-0.5		9	V
Receiver Data Output	All States	RXD	-0.5		V _{cc} +0.5	V
Transmitter Data Input	All States	TXD	-0.5		V _{cc} +0.5	V
Shut Down	All States	SD	-0.5		V _{cc} +0.5	V
Operating Temperature Range		T _{amb}	-25		+85	°C
Storage Temperature Range		T _{stg}	-40		+85	°C
Soldering Temperature	See Recommended Solder Profile			-	245	°C
Average IrED Current		I _{IrED} (DC)			100	mA
Repetitive Pulsed IrED Current	t<50 μs, t _{on} <20%	I _{IrED} (RP)			400	mA

Electrical Characteristics

T_{amb}=25°C, V_{cc}=2.0V to 5.5V unless otherwise noted.

Typical values are for DESIGN AID ONLY, not guaranteed nor subject to production testing.

Parameters	Test Conditions / Pins	Symbol	Min.	Typ.	Max.	Unit
Transceiver						
Supply Voltage	Receive Mode Transmit Mode, R2=3.9Ω	V _{cc}	2.0		5.5	V
Supply Current Pin V _{cc} (Reecive Mode)	V _{cc} =2 to 5.5V	I _{cc} (Rx)		145		uA
Supply Current Pin V _{cc} (avg) (Transmit Mode)	I _{IrED} =400mA (at IrED Anode Pin) V _{cc} =5V	I _{cc1} (Tx)		12		mA
Shut Down Current Pin SD	SD=V _{cc} =2 to 5.5V	I _{SD}		0.01	1	uA
Transmit Receiver Latency		T _{TRL}		50	100	uA
Transceiver Power On Setting Time		T _{PON}		100	150	us

Device NO:DTM-321-001



TM3201/TR2

Opto-electronic Characteristics

Tamb=25°C, Vcc=2.0V to 5.5V unless otherwise noted.

Typical values are for DESIGN AID ONLY, not guaranteed nor subject to production testing.

Parameters	Test Conditions	Symbol	Min.	Typ.	Max.	Unit
Receiver						
Minimum Detection Threshold Irradiance	SIR Mode, Vcc=5V	Ee	-	-	4	uW/cm ²
	SIR Mode, Vcc=3V	Ee	-	-	10	uW/m ²
Maximum Detection Threshold Irradiance	SIR Mode, Vcc=5V	Ee	-	500		uW/cm ²
	SIR Mode, Vcc=3V	Ee	-	1000		uW/cm ²
Logic LOW Receiver Input Irradiance		Ee			0.4	uW/cm ²
Output Voltage -Active	Vcc=5V, Iol=8mA	V _{OL}	-	0.22		V
	Vcc=2V, Iol=2mA	V _{OL}	-	0.17		V
Output Voltage -Non active	Vcc=5V, Iol=8mA	V _{OH}		4.6	-	V
	Vcc=2V, Iol=2mA	V _{OH}		1.7	-	V
RXD short circuit	Vcc=5V, RXD=0, RXD=Vcc		-	40	-	mA
	Vcc=2V, RXD=0, RXD=Vcc		-	8	-	mA
Rise/Fall Time-RXD	Vcc=5V, C=15pF	t _r /t _f (RXD)		30		ns
	Vcc=2V, C=15pF	t _r /t _f (RXD)		63		ns
Transmitter						
IrED Operating Current	Low Power Mode Vcc=2 to 5.0V	I _{IrED}		30	45	mA
Logic LOW Transmitter Input Voltage		V _{IL}	0		0.8	V
Logic HIGH Transmitter Input Voltage		V _{IH}	2.0		Vcc+0.5	V
Output Radiant Intensity	Vcc=5.0V	I _e	-	50	500	mW/sr
	TXD Logic LOW Level	I _e			0.04	mW/sr
Angle of Half Intensity		2θ _{1/2}	30			°
Peak Wavelength of Emission		λ _p	850	870	900	nm
Half-Width of Emission Spectrum		Δλ		40		nm
Optical Rise/Fall Time,		t _r /t _f		200	600	ns
Optical Overshoot					25	%

Device NO:DTM-321-001

Recommended Circuit Diagram

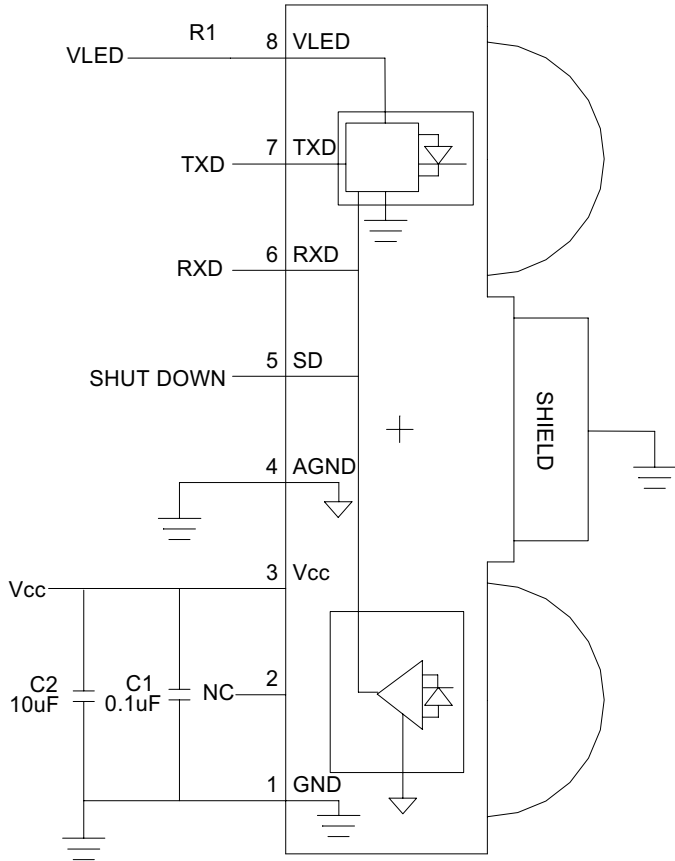

Note: Outlined components are optional depending on the quality of the power supply.

Component	Recommended Value
C1	0.1uF, Ceramic
C2	10uF, Electrolytic

C2 is optional for the same supply voltage of Vcc and V_{LEDA}

Recommended SMD Pad Layout

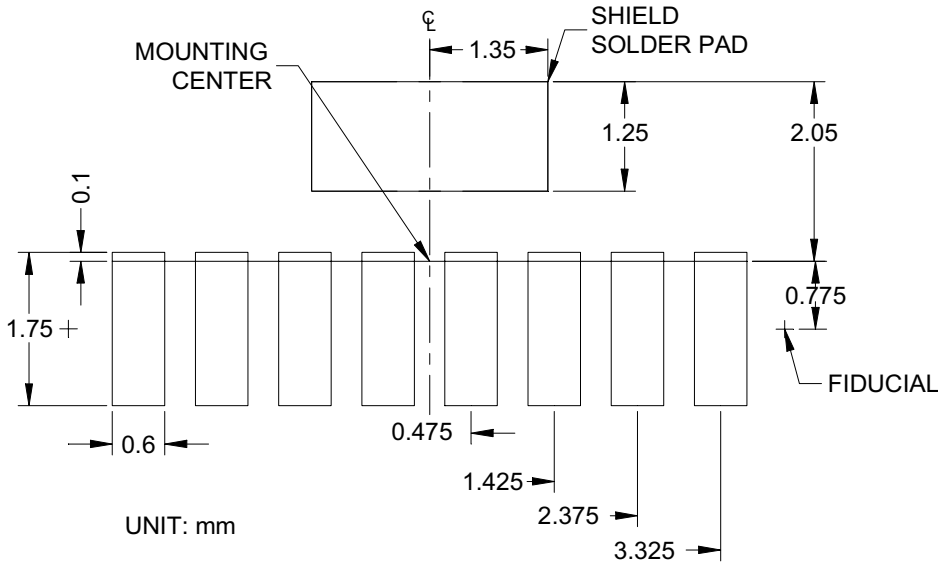

Recommended Solder Profile

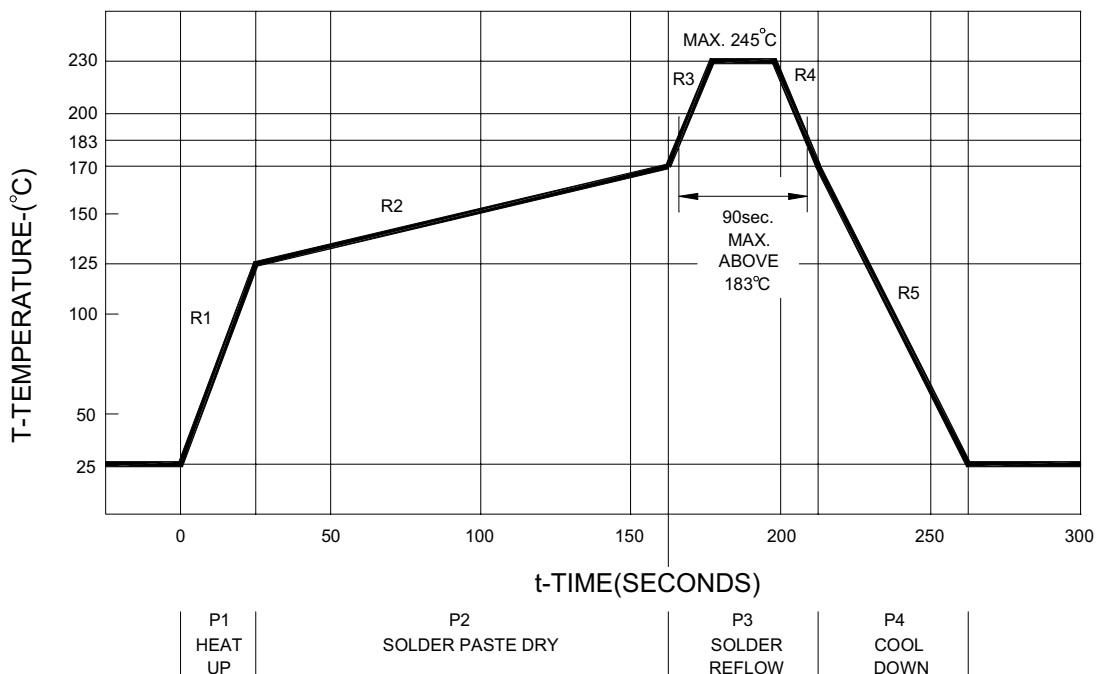

EVERLIGHT ELECTRONICS CO., LTD.
 Office: No 25, Lane 76, Sec 3, Chung Yang Rd,
 Tucheng, Taipei 236, Taiwan, R.O.C

Tel: 886-2-2267-2000, 2267-9936
 Fax: 886-2267-6244, 2267-6189, 2267-6306
<http://www.everlight.com>

Device NO:DTM-321-001