INTELLIGENTE ANZEIGEN

INTELLIGENT DISPLAYS



INTELLIGENTE ANZEIGEN

EIGENSCHAFTEN

Einzelbausteine

Intelligente Anzeigen sind alphanumerische LED Displays mit eingebautem CMOS-Schaltkreis. Sie sind völlig unabhängige, anwenderfreundliche Peripheriebausteine, die eine große Vielfalt von Gestaltungsmöglichkeiten zulassen, Entwicklungszeit einsparen und -kosten reduzieren.

- ASCII-Zeichensatz für 128 und 256 Zeichen, oder
- Frei programmierbarer Zeichensatz
- Helle, kontraststarke LED-Technologie
- CMOS-Logik, TTL-kompatibel mit
 - Speicher
 - Multiplexer
- Betrieb mit einer einzigen 5 V Versorgungsspannung
- Keine meßbare Degradation, sehr hohe Lebenserwartung
- Kompatibel zu 8-bit-Microcomputer-Systemen
- Zugriffszeit von 525 ns bis 45 ns
- Direkter, unabhängiger Zugriff auf jede Stelle
- Sehr kompakte, flache Gehäuse
- Einfach aneinanderreihbar für erweiterte Textlängen
- Helligkeitscode für gleichmäßig leuchtende Anzeige

EINBAUHINWEISE

Handhabung

ESD-Vorsichtsmaßnahmen sind zu beachten

- Vermeiden Sie, Anschlüsse zu berühren. Fassen Sie nur am Gehäuse an.
- Transportieren Sie die Bausteine nur in antistatischen Schienen oder auf leitendem Material.
- Die Arbeitsumgebung muß leitend geerdet sein (leitender Fußboden, leitende Arbeitstische, individuelle Handgelenk-Ableitbänder, usw.)

Löten

- Max. Löttemperatur: 260 °C
- Max. Lötzeit: 5 s
- Min. Lötabstand: > 1,59 mm

Bei Wellenlötbadern darf die Gehäusetemperatur die max. Betriebstemperatur nicht überschreiten.

Es muß wasserlösliches bzw. alkoholfreies Flußmittel verwendet werden.

Lösungsmittel

Zum Reinigen der Platinen keine alkoholhaltigen Lösungsmittel benutzen.

INTELLIGENT DISPLAYS

FEATURES

Display devices

Intelligent displays are alphanumeric LED displays with built-in CMOS circuits. They are totally self-contained peripherals which allow a wide variety of design configurations, minimize design time and reduce design costs.

- ASCII character set for 128 and 256 characters, or
- User definable characters
- Bright, high-contrast LED technology
- CMOS logic, TTL-compatible with
 - memory
 - multiplexer
- Single 5 V operation
- No noticeable degradation, a very high life expectancy
- Compatible with 8-bit microprocessor systems
- Access time from 525 ns up to 45 ns
- Independent access to each digit
- Highly compact, flat packages
- Easily stackable for longer message lengths
- Intensity coded for display uniformity

MOUNTING INSTRUCTIONS

Handling

Observe ESD precautions

- Avoid touching the pins; handle the body only.
- Keep the devices in anti-static tubes or conductive material when transporting
- Use a conductive and grounded work area (conductive flooring, conductive work benches, individual wrist straps, etc.)

Soldering

- Max. soldering temperature: 260 °C
- Max. soldering time: 5 s
- Min. solder distance: > 1.59 mm

In case of wave soldering, the package temperature of intelligent displays is not allowed to exceed the max. operating temperature.

It is necessary to use water soluble or alcohol-free soldering flux.

Solvents

Do not use any cleaning solvents containing alcohol.



EINZELBAUSTEINE

DISPLAY DEVICES

Package	Type	No. of characters	Character height [mm]	Viewing angle x-/y-axis Operating temperature No. of dots per character	Max. current consumption, conditions at 25 °C	Characteristics and applications	Ordering code	Fig.
---------	------	-------------------	-----------------------	---	---	----------------------------------	---------------	------



Punktmatrix-Anzeigen mit 96-ASCII-Zeichen

Dot Matrix with 96 ASCII characters

	DLO 7135 HER**	1	17.3	±75 deg. -40 ... +85 °C 5 x 7 dots	$I_{CC} = 140 \text{ mA}$ $V_{CC} = 5 \text{ V}$ 20 dots on (100% brightness)	<ul style="list-style-type: none"> • Display blank • 3 brightness levels • Industrial controllers • Instrumentation • Control units 	Q68000-A7157	7
	DLG 7137 green						Q68000-A7159	
	DLO 4135 HER**	1	10.9	±75 deg. -40 ... +85 °C 5 x 7 dots	$I_{CC} = 140 \text{ mA}$ $V_{CC} = 5 \text{ V}$	<ul style="list-style-type: none"> • Display blank • 3 brightness levels • Industrial controllers • Instrumentation • Control units 	Q68000-A4297	11
	DLG 4137 green						Q68000-A4299	

Programmierbare Anzeigen mit 128-ASCII-Zeichen

Programmable displays with 128 ASCII characters

	PD 2435 HER**	4	5.1	±55/ ±65 deg. -40 ... +85 °C 5 x 7 dots	$I_{CC} = 130 \text{ mA}$ $V_{CC} = 5 \text{ V}$ 80 dots on (100% brightness)	<ul style="list-style-type: none"> • Software-controlled features • Read and write capability • Machine and robot controllers • Control units • Medical equipment 	Q68000-A3561	8
	PD 2436 red						Q68000-A8366	
	PD 2437 green						Q68000-A3562	
	PD 3535 HER**	4	6.86	±55/ ±65 deg. -40 ... +85 °C 5 x 7 dots	$I_{CC} = 165 \text{ mA}$ $V_{CC} = 5 \text{ V}$ 80 dots on (100% brightness)	<ul style="list-style-type: none"> • Software-controlled features • Read and write capability • Machine and robot controllers 	Q68000-A7964	9
	PD 3536 red						Q68000-A8365	
	PD 3537 green						Q68000-A7965	
	PD 4435 HER**	4	11.43	±55/ ±65 deg. -40 ... +85 °C 5 x 7 dots	$I_{CC} = 170 \text{ mA}$ $V_{CC} = 5 \text{ V}$ 80 dots on (100% brightness)	<ul style="list-style-type: none"> • Control units • Medical equipment • Aeronautics 	Q68000-A8367	12
	PD 4436 red						Q68000-A8368	
	PD 4437 green						Q68000-A8369	

8-stellige 5 x 7-Punktmatrix

8 digit 5 x 7 dot matrix

	PDSP 2110 red	8	5.1	±55/ ±65 deg. 5 x 7 dots	$I_{CC} = 370 \text{ mA}$ $V_{CC} = 5 \text{ V}$ 160 dots on (100% brightness)	<ul style="list-style-type: none"> • Built-in 2 page character ROM • Software-controlled features • Machine and robot controllers • Medical equipment • Avionics and navigational equipment • Instrumentation 	Q68000-A8474	14
	PDSP 2111 yellow						Q68000-A8503	
	PDSP 2112 HER**						Q68000-A8504	
	PDSP 2113 green						Q68000-A8505	
	PDSP 2114 HEG*						Q68000-A8533	

* HEG = High Efficiency Green

** HER = High-Efficiency Red

INTELLIGENTE ANZEIGEN

INTELLIGENT DISPLAYS

Package	Type	No. of characters	Character height [mm]	Viewing angle x-/y-axis No. of dots per character	Max. current consumption, conditions at 25 °C	Characteristics and applications	Ordering code	Fig.
---------	------	-------------------	-----------------------	--	---	----------------------------------	---------------	------

8-stellige 5 x 7-Punktmatrix

8 digit 5 x 7 dot matrix (cont'd)

	HDSP 2110S red	8	5.1	±55/ ±65 deg. 5 x 7 dots	$I_{CC} = 370 \text{ mA}$ $V_{CC} = 5 \text{ V}$ 160 dots on (100% brightness)	<ul style="list-style-type: none"> • 128 special ASCII characters (English plus 5 other languages) • 16 free programmable characters • Software-controlled features • Machine and robot controllers • Medical equipment • Avionics and navigational equipment • Instrumentation 	Q68000-A8560	14
	HDSP 2111S yellow						Q68000-A8561	
	HDSP 2112S HER**						Q68000-A8562	
	HDSP 2113S green						Q68000-A8563	
	HDSP 2114S HEG*						Q68000-A8564	
	HDSP 2115S orange						Q68000-A8907	

8-stellige 5 x 5-Punktmatrix

8 digit 5 x 5 dot matrix



	PLCD 5580 red	8	3.68	±50/ ±65 deg. 5 x 5 dots	$I_{CC} = 290 \text{ mA}$ $V_{CC} = 5 \text{ V}$ 128 dots on (100% brightness)	<ul style="list-style-type: none"> • Built-in 2 page 256 character ROM • Programmable features: individual flashing character, full display blinking, multi-level dimming and blanking • Clear function • Lamp test • Low power 	Q68000-A8895	1
	PLCD 5581 yellow						Q68000-A8896	
	PLCD 5582 HER**						Q68000-A8897	
	PLCD 5583 green						Q68000-A8898	
	PLCD 5584 HEG*						Q68000-A8899	

DOMINO SERIE

Punktmatrix-Anzeigen

DOMINO SERIES

Dot matrix displays



	DLR 1414 red	4	3.7	±50/ ±75 deg. 5 x 7 dots	$I_{CC} = 105 \text{ mA}$ $V_{CC} = 5 \text{ V}$ 80 dots on	<ul style="list-style-type: none"> • Dot matrix drop-in replacement for DL 1414T. • 128 special ASCII characters English plus 5 other languages. • Access time 110 ns. • For portable applications; telecommunications equipment. 	Q68000-A8091	10 (DLX 1414)
	DLO 1414 HER**						Q68000-A8092	
	DLG 1414 green						Q68000-A8093	
	DLR 2416 red	4	5	±50/ ±75 deg. 5 x 7 dots	$I_{CC} = 130 \text{ mA}$ $V_{CC} = 5 \text{ V}$ 80 dots on	<ul style="list-style-type: none"> • Dot matrix drop-in replacement for DL 2416T. • 128 special ASCII characters English plus 5 other languages. • Access time 110 ns. • For instrumentation equipment. 	Q68000-A8094	5 (DLX 2416)
	DLO 2416 HER**						Q68000-A8095	
	DLG 2416 green						Q68000-A8096	
	DLR 3416 red	4	6.9	±50/ ±75 deg. 5 x 7 dots	$I_{CC} = 165 \text{ mA}$ $V_{CC} = 5 \text{ V}$ 80 dots on	<ul style="list-style-type: none"> • Dot matrix drop-in replacement for DL 3416T. • 128 special ASCII characters English plus 5 other languages. • Access time 110 ns. • For instrumentation equipment. 	Q68000-A8097	6 (DLX 3416)
	DLO 3416 HER**						Q68000-A8098	
	DLG 3416 green						Q68000-A8099	

* HEG = High Efficiency Green

** HER = High-Efficiency Red

INTELLIGENTE ANZEIGEN

INTELLIGENT DISPLAYS

Package	Type	No. of characters	Character height [mm]	Viewing angle x-/y-axis No. of dots per character	Max. current consumption, conditions at 25 °C	Characteristics and applications	Ordering code	Fig.
7 mm Punktmatrix-Anzeigen ROM-freie serielle Eingabe, Einzelpunkte adressierbar				7 mm Dot matrix displays ROM-less serial input, dot addressable				
	SCF 5740 red	4	6.86	±55/ ±55 deg. 5 x 7 dots	$I_{CC} = 186 \text{ mA}$ $V_{CC} = 5 \text{ V}$ 80 dots on	<ul style="list-style-type: none"> Attributes - 140 bit RAM for user defined characters - Eight dimming levels - Power down mode - Hardware/software clear functions - Internal or external clock 	Q68000-A8848	2
	SCF 5741 yellow						Q68000-A8900	
	SCF 5742 HER**						Q68000-A8901	
	SCF 5743 green						Q68000-A8902	
	SCF 5744 HEG*						Q68000-A8903	
	SCF 5781 yellow	8	6.86	±55/ ±55 deg. 5 x 7 dots	$I_{CC} = 300 \text{ mA}$ $V_{CC} = 5 \text{ V}$ 160 dots on	<ul style="list-style-type: none"> Attributes - 280 bit RAM for user defined characters - 16 dimming levels - Power down mode (<250 µW) - Hardware/software clear functions - Internal clock 	Q68100-A1414	25
	SCF 5782 HER**						Q68100-A1415	
	SCF 5783 green						Q68100-A1416	
	SCF 5784 HEG*						Q68100-A1359	
	SCF 5785 orange						Q68100-A1417	

* HEG = High Efficiency Green

** HER = High-Efficiency Red

SAMSAN SERIE

Mit der langjährigen Erfahrung, die OSRAM OS im Bereich CMOS-Anzeigen erworben hat, konnte eine Alternative zu den energieschluckenden, in Bipolar-Technologie aufgebauten Small Alphanumeric Displays entwickelt werden. Diese neue Familie von vier 5 x 7-Punktmatrixzeichen hat zwei 14-bit-CMOS-Schieberegister für serielle Eingabe und einen integrierten CMOS-Zeilentreiber. Zusätzlich zu den hermetisch dichten Glas- und Keramikgehäusen läßt der niedrige Energiebedarf kostengünstigere Plastikgehäuse für gewerbliche Anwendungen zu. Die neuen Anzeigen sind mit 3,7 mm und 4,9 mm Zeilenhöhe in den vier Farben - rot, HER**, grün, gelb - lieferbar. Eine Lesbarkeit bei Sonnenlicht ist gewährleistet.

OSRAM OS-Vorteile gegenüber Konkurrenzprodukten:

- Intelligente CMOS IC ermöglichen:
 - Niedrige Verlustleistung bei gleicher Helligkeit
 - 25 x geringerer Ruhestrom
 - 30% durchschnittliche Energieeinsparung
- Großer Betriebstemperaturbereich
 - militärische, hermetisch dichte Keramikgehäuse (MSD/ISD-Version)
 - 55 °C...+100 °C gegenüber -40 °C...+85 °C
- Große Gehäusevielfalt
 - Plastikgehäuse für allgemeine Anforderungen
 - Keramikgehäuse für sehr hohe industrielle und militärische Anforderungen

SAMSAN SERIES

OSRAM OS has used its long experience in CMOS display modules to offer a superior CMOS alternative to existing Small Alphanumeric Displays with power-hungry bipolar technology. This new family of 4-character, 5 x 7 dot matrix LED display modules has on board serial input shift registers and row driver CMOS ICs. In addition to the hermetic ceramic packages, the lower power consumption permits the introduction of lower cost plastic packages for commercial applications. These displays are available in .15" and .20" character heights, in four colours - red, HER**, green and yellow - and in sunlight-viewable versions.

OSRAM OS advantages over competitors' products:

- On-board CMOS ICs result in:
 - Lower power dissipation with equal brightness
 - 25 x less quiescent current
 - 30% average power savings
- Wider operating temperature ranges
 - Military hermetic ceramic package (MSD/ISD-version)
 - 55 °C...+100 °C versus -40 °C...+85 °C
- Wider package choice
 - New plastic packages for commercial applications
 - Ceramic packages for hi-grade industrial and military uses

INTELLIGENTE ANZEIGEN

INTELLIGENT DISPLAYS

SAMSAN SERIE

SAMSAN SERIES

Package	Type/ Color	No. of characters	Character height [mm]	Viewing angle x-/y-axis	No. of dots per character	Temperature range	Features/ Applications	Ordering code	Fig.
---------	----------------	----------------------	-----------------------------	----------------------------	------------------------------	----------------------	---------------------------	---------------	------

Kompakte alphanumerische Anzeigen

Commercial small alphanumeric displays (cont'd)

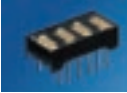
	HDSP 2000 LP red	4	3.7	±50/ ±75 deg.	35 (5 x 7)	Operating -40 ... +85 °C Storage -40 ... +100 °C	<ul style="list-style-type: none"> Plastic package Serial input/parallel output, low power on-board CMOS shift registers, constant current LED row drivers. External column strobing gives full ASCII and customized fonts. Easily cascaded for multiple displays. 	Q68000-A8131	13 (HDSP 200XLP)
	HDSP 2001 LP yellow							Q68000-A8304	
	HDSP 2002 LP HER**							Q68000-A8132	
	HDSP 2003 LP bright green							Q68000-A8133	

SLIMLINE SERIE

SLIMLINE SERIES

5 x 7-Punktmatrix

5 x 7 dot matrix

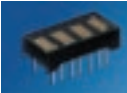

	SLR 2016 red	4	4.72	±50/ ±75 deg.	35 (5 x 7)	Operating -40 ... +85 °C Storage -40 ... +100 °C	<ul style="list-style-type: none"> Optimum display surface efficiency Very close multi-line spacing, 0.4" centers. 128 special ASCII characters (English plus 5 other languages) Clear function that clears character memory True blanking for intensity dimming applications 	Q68000-A8640	15
	SLO 2016 HER**							Q68000-A8641	
	SLG 2016 green							Q68000-A8642	
	SLY 2016 yellow							Q68000-A8643	

5 x 5-Punktmatrix

5 x 5 dot matrix

ROM-freie serielle Eingabe, Einzelpunkte adressierbar

ROM-less, serial input, dot addressable

	SCD 5580A red	8	3.68	±50/ ±65 deg.	25 (5 x 5)	Operating -40 ... +85 °C Storage -40 ... +100 °C	<ul style="list-style-type: none"> Optimum display surface efficiency Lower power - 30% less power dissipation than 5 x 7 format High speed data input rate - 5 MHz Readable from 6 feet (1.8 meters) Attributes <ul style="list-style-type: none"> - 200/250 bit RAM for user defined characters - Eight dimming levels - Power down mode (<250 µW) - Hardware/software clear function - Lamp test Internal or external clock 	Q68100-A0994	16
	SCD 5581A yellow							Q68100-A0996	
	SCD 5582A HER**							Q68100-A0997	
	SCD 5583A green							Q68100-A0998	
	SCD 5584A HEG*							Q68100-A1000	
	SCD 55100 red	10	3.68	±50/ ±65 deg.	25 (5 x 5)	Operating -40 ... +85 °C Storage -40 ... +100 °C	<ul style="list-style-type: none"> Internal or external clock 	Q68000-A8635	17
	SCD 55101 yellow							Q68000-A8636	
	SCD 55102 HER**							Q68000-A8637	
	SCD 55103 green							Q68000-A8638	
	SCD 55104 HEG*							Q68000-A8639	

* HEG = High Efficiency Green

** HER = High-Efficiency Red

INTELLIGENTE ANZEIGEN

INTELLIGENT DISPLAYS



Package	Type/ Color	No. of characters	Character height [mm]	Viewing angle x-/y-axis	No. of dots per character	Temperature range	Features/ Applications	Ordering code	Fig.
---------	----------------	----------------------	-----------------------------	----------------------------	------------------------------	----------------------	---------------------------	---------------	------

5 x 5-Punktmatrix

ROM-freie serielle Eingabe, Einzelpunkte adressierbar

5 x 5 dot matrix

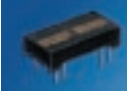
ROM-less, serial input, dot addressable (cont'd)

	SCDV 5540 red	4	3.2	±55/ ±55 deg.	25 (5 x 5)	Operating -40 ... +85 °C Storage -40 ... +100 °C	Vertical format	Q68000-A8890	3
	SCDV 5541 yellow							Q68000-A8891	
	SCDV 5542 HER**							Q68000-A8892	
	SCDV 5543 green							Q68000-A8893	
	SCDV 5544 HEG*							Q68000-A8894	
	SCE 5740 red	4	4.7	±55/ ±65 deg.	25 (5 x 5)	Operating -40 ... +85 °C Storage -40 ... +100 °C	Programmable features: • Clear function • Eight dimming levels • Peak current select • prescaler function • Internal or external clock	Q68100-A1369	24
	SCE 5741 yellow							Q68100-A1370	
	SCE 5742 HER**							Q68100-A1371	
	SCE 5743 green							Q68100-A1372	
	SCE 5744 HEG*							Q68100-A1373	
	SCE 5745 orange							Q68100-A1374	
	SCE 5780 red	8	4.7	±55/ ±65 deg.	25 (5 x 5)	Operating -40 ... +85 °C Storage -40 ... +100 °C	Programmable features: • Clear function • Eight dimming levels • Peak current select • prescaler function • Internal or external clock	Q68000-A9100	4
	SCE 5781 yellow							Q68000-A9101	
	SCE 5782 HER**							Q68000-A9102	
	SCE 5783 green							Q68000-A9103	
	SCE 5784 HEG*							Q68000-A9104	

5 x 7 Punktmatrix

Parallel input

5 x 7 Dot matrix

Parallel input

	PDSP 1880 red	8	4.7	±55/ ±65 deg.	35 (5 x 7)	Operating -40 ... +85 °C Storage -40 ... +100 °C	• Plastic package • External column strobing gives full ASCII and customized fonts. • Easily cascaded for multiple displays.	Q68000-A9105	18
	PDSP 1881 yellow							Q68000-A9106	
	PDSP 1882 HER**							Q68000-A9107	
	PDSP 1883 green							Q68000-A9108	
	PDSP 1884 HEG*							Q68000-A9109	

* HEG = High Efficiency Green

** HER = High-Efficiency Red

INTELLIGENTE ANZEIGEN

INTELLIGENT DISPLAYS

Package	Type/ Color	No. of characters	Character height [mm]	Viewing angle x-/y-axis	No. of dots per character	Temperature range	Features/ Applications	Ordering code	Fig.
---------	----------------	----------------------	-----------------------------	----------------------------	------------------------------	----------------------	---------------------------	---------------	------

Hi rel
Alphanumerische programmierbare Anzeigen

Hi rel
Alphanumeric Programmable Displays

	IPD 2131 yellow	8	4.85	-	35 (5 x 7)	-55 ... +100 °C	<ul style="list-style-type: none"> Programmable Display Devices Eight 5 x 7 dot matrix characters. Built-in CMOS ASCII decoder, multiplexer, memory, and driver. 128 character ASCII character set. Rugged ceramic package, hermetically sealed flat glass lens. 	Q68000-A8903	19
	IPD 2132 HER**							Q68000-A8836	
	IPD 2133 HEG*							Q68000-A8906	



Hi rel
5 x 7 Punktmatrix
Alphanumerische programmierbare
Anzeigen mit CMOS Kontrollfunktion

Hi rel
5 x 7 Dot-Matrix
Alphanumeric Programmable
Displays with CMOS Control Functions

	IPD 2545 A HER**	4	6.4	-	35 (5 x 7)	-55 ... +100 °C	<ul style="list-style-type: none"> Programmable Display Devices Four 5 x 7 dot matrix characters. Built-in CMOS ASCII decoder, multiplexer, memory, and driver. 128 character ASCII character set. Rugged ceramic package, hermetically sealed flat glass lens. 	Q68000-A9883	20
	IPD 2547 A green							Q68000-A9884	

Hi rel
5 x 7 Punktmatrix mit seriellem Dateneingang

Hi rel
5 x 7 Dot-Matrix with Serial Input

	ISD 2010 red	4	3.7	-	35 (5 x 7)	-55 ... +100 °C	<ul style="list-style-type: none"> Small Alphanumeric Displays Four 5 x 7 dot matrix characters. Rugged ceramic package, hermetically sealed flat glass lens. Serial input. Easily cascaded for multiple displays. Low power, on-board CMOS shift register and constant current LED row drivers. External column strobing allows use of full ASCII and customized fonts. 	Q68000-A8134	21
	ISD 2011 yellow							Q68000-A8135	
	ISD 2012 HER**							Q68000-A8136	
	ISD 2013 HEG*							Q68000-A8137	
	ISD 2310 red	4	4.88	-	35 (5 x 7)	-55 ... +100 °C	<ul style="list-style-type: none"> Small Alphanumeric Displays Four 5 x 7 dot matrix characters. Rugged ceramic package, hermetically sealed flat glass lens. Serial input. Easily cascaded for multiple displays. Low power, on-board CMOS shift register and constant current LED row drivers. External column strobing allows use of full ASCII and customized fonts. 	Q68000-A8138	22
	ISD 2311 yellow							Q68000-A8139	
	ISD 2312 HER**							Q68000-A8140	
	ISD 2313 HEG*							Q68000-A8141	

* HEG = High Efficiency Green

** HER = High-Efficiency Red

INTELLIGENTE ANZEIGEN

INTELLIGENT DISPLAYS

Package	Type/ Color	No. of characters	Character height [mm]	Viewing angle x-/y-axis	No. of dots per character	Temperature range	Features/ Applications	Ordering code	Fig.
---------	----------------	----------------------	-----------------------------	----------------------------	------------------------------	----------------------	---------------------------	---------------	------

Hi rel
5 x 7 Punktmatrix mit seriellem Dateneingang

Hi rel
5 x 7 Dot-Matrix with Serial Input

	ISD 2351 yellow	4	4.88	-	35* (5 x 7)	-55 ... +100 °C	<ul style="list-style-type: none"> • Small Alphanumeric Displays • Sunlight viewable. • Four 5 x 7 dot matrix characters. • Rugged ceramic package, hermetically sealed flat glass lens. • Serial input. Easily cascaded for multiple displays. Low power on-board CMOS shift register and constant current LED row drivers. • External column strobing allows use of full ASCII and customized fonts. 	Q68000-A8142	23
	ISD 2352 HER**							Q68000-A8143	
	ISD 2353 HEG*							Q68000-A8144	

* HEG = High Efficiency Green

** HER = High-Efficiency Red

Maßbilder in inch (mm)

Outline drawings dimensions in inch (mm)

Figure 1 PLCD 558X

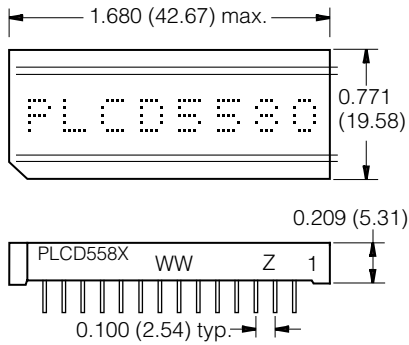

Figure 2 SCF 574X

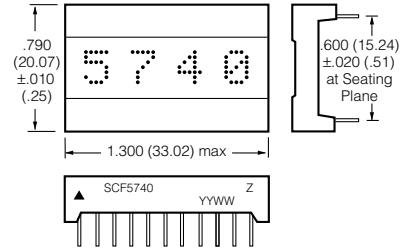

Figure 3 SCDV 554X

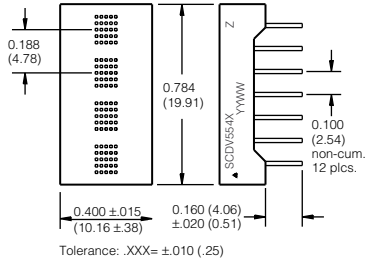

Figure 4 SCE 578X

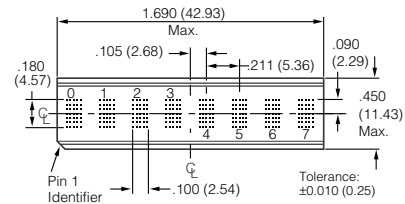

Figure 5 DLX 2416

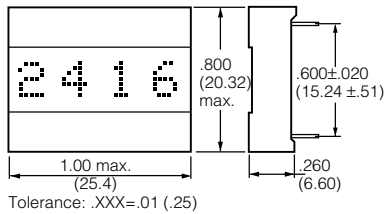

Figure 6 DLX 3416

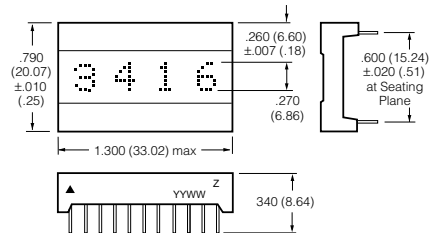

Figure 7 DLO 7135, DLG 7137

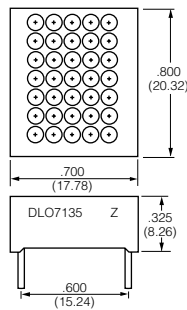
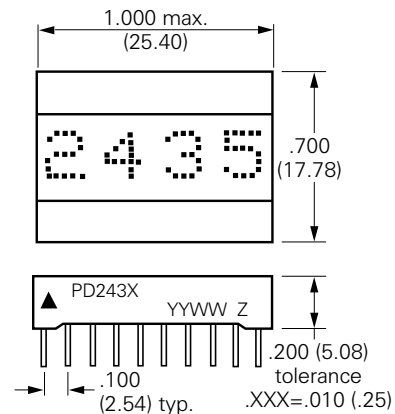

Figure 8 PD 2435, PD 2436, PD 2437



Maßbilder in inch (mm)

Outline drawings dimensions in inch (mm)

Figure 9 PD 3535, PD 3536, PD 3537

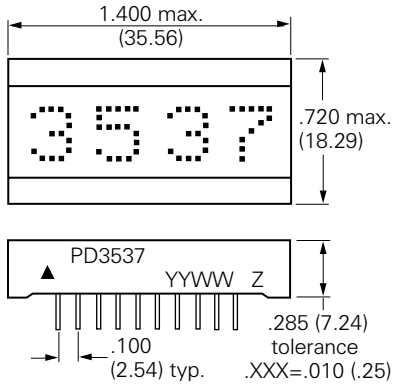

Figure 10 DLX 1414

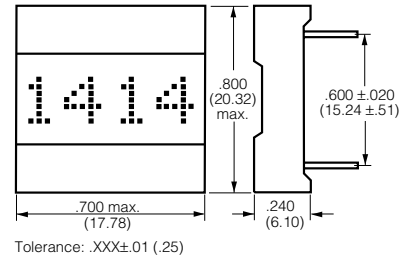

Figure 11 DLO 4135, DLG 4137

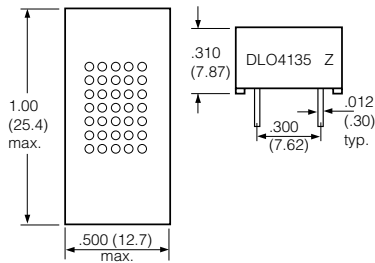

Figure 12 PD 4435, PD 4436, PD 4437

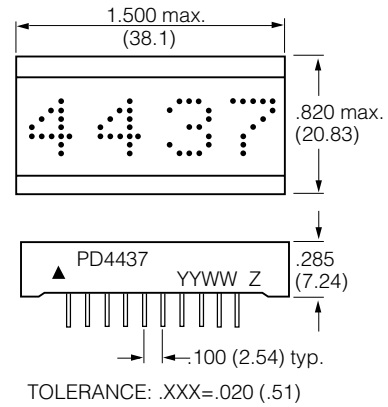

Figure 13 HDSP 200X LP

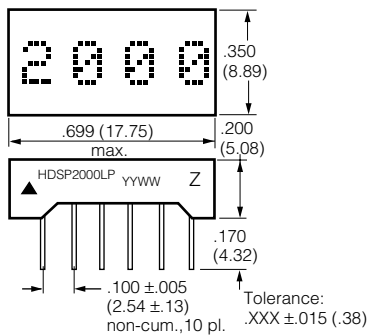
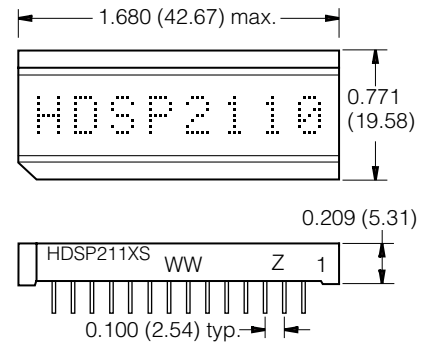

Figure 14 PDSP 211X, HDSP 211X



Maßbilder in inch (mm)

Outline drawings dimensions in inch (mm)

Figure 15 SLX 2016

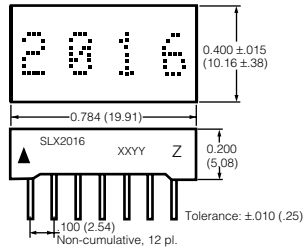

Figure 16 SCD 558xA

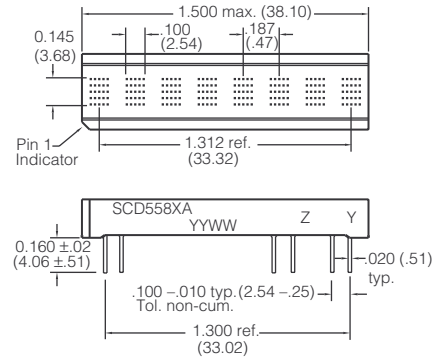

Figure 17 SCD 5510X

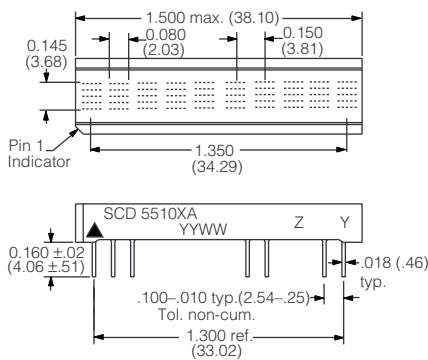

Figure 18 PDSP 188X

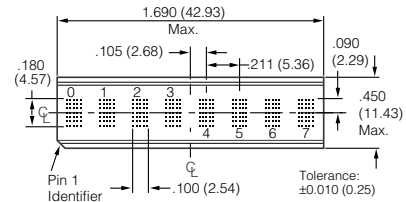

Figure 19 IPD 213X

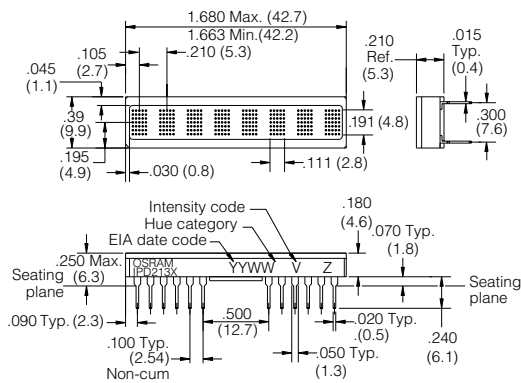
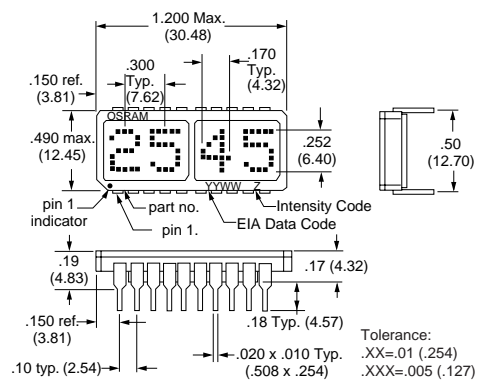

Figure 20 IPD 2545 A, IPD 2547 A



Maßbilder in inch (mm)

Outline drawings dimensions in inch (mm)

Figure 21 ISD 201X

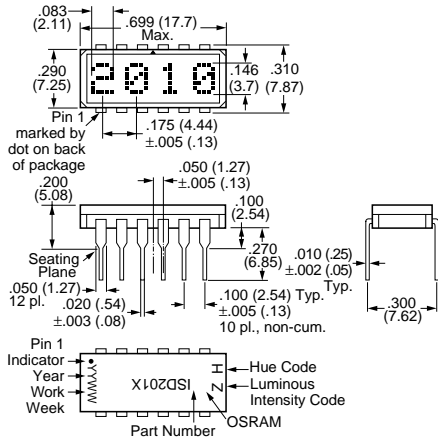

Figure 22 ISD 231X

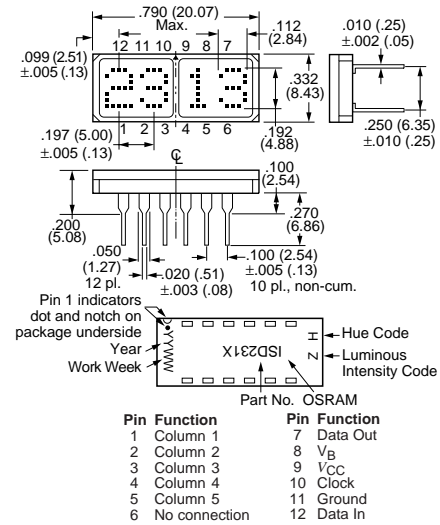

Figure 23 ISD 235X

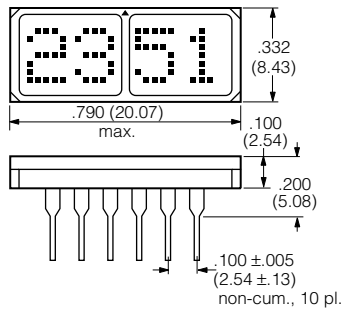

Figure 24 SCE 574X

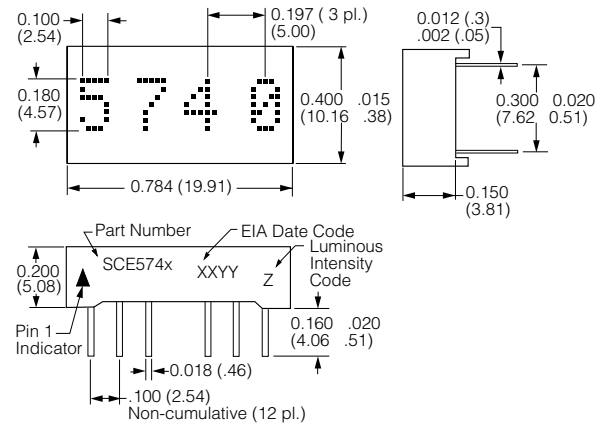
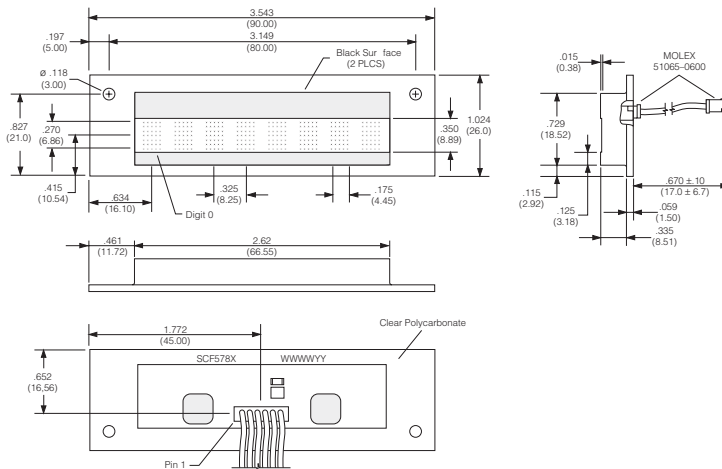

Figure 25 SCF 578X



Tolerance: x.xx ±.005 (x.xx ±.13)

INTELLIGENTE GRAPHIK ANZEIGEN

INTELLIGENT GRAPHIC DISPLAYS

Intelligente Grafikanzeigen sind 16 x 16 Punktmatrix-Anzeigen mit 3 mm große LED Punkten im Abstand von 4 mm. Diese jeweils 64 mm x 64 mm großen Module sind in X- und Y-Richtung zusammensteckbar und erlauben dem Benutzer eine beliebig dimensionierbare Vollfarbgrafikanzeige für Innen- und Semiaußenanwendungen aufzubauen. Die integrierten ICs ermöglichen eine Ansteuerung über die serielle Schnittstelle. Für den Treiber kann ein interner oder externer Multiplexmode mit 32 Helligkeitsstufen und einem Kontrastverhältnis von 1 : 8 ausgewählt werden. Standard-Produkte mit Typenbezeichnungen wie unten angegeben werden aus InGaAIP (rot), InGaN (grün) und GaN (blau) LEDs gefertigt. Konfigurationen für bicolor oder monochrom sind ebenso erhältlich. Einzelne auf das PCB aufgedruckte Linsen ermöglichen eine gute Lesbarkeit und einen sehr großen Sichtwinkel.

Intelligent Graphic Displays are 16 x 16 dot matrix displays with 3 mm diameter dot size and 4 mm pixel pitch. These 64 x 64 mm boards are X- and Y- cascadable and allow the user to build up displays of arbitrary size for indoor and semi-outdoor applications. On-board ICs provide drive and control functions via serial interface. An internal or external multiplex mode can be selected for the on-board driver with 32 levels of global brightness control and a multiplex ratio of 1 : 8. Standard products, with part numbers indicated below, have RGB pixels made from high brightness InGaAIP red, InGaN green and GaN blue LEDs. Special configurations with other RGB, bicolor and monochrome LEDs are available as well. Printed lenses on the PCB form pixels that achieve excellent readability and very wide-angle viewing.

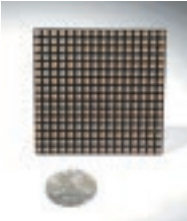
Package	Type	Color	Wavelength (dominant) nm	Brightness (typical) cd/m ²	Ordering code	Fig.
	IG4M1616A1	red	625	50	on request	26
		green	572	220	on request	
		blue	430	50	on request	
		white (balanced)		275	on request	
		R+G+B (total)		320	on request	
	IG4M1616A3	red	625	390	on request	
		green	525	600	on request	
		blue	430	100	on request	
		white (balanced)		900	on request	
		R+G+B (total)		1090	on request	

Pixel brightness matching $\pm 30\%$ for each color within a module.

Maßbild in inch (mm)

Outline drawing dimensions in inch (mm)

