

Photo IC for encoder

S4506

Photo IC for photointerrupters with encoder functions



S4506 incorporates a 4-element photodiode array that provides 2-phase digital output in response to the input light status. Photointerrupters with encoder functions can be easily configured by using S4506.

Features

- 2-phase (phases A and B) digital output
- Integrated with 4-element photodiode (pitch: 0.39 mm)
- Direct TTL connection
- Miniature plastic package

Applications

- Encoders for office machine, robots, and NC machines

■ Absolute maximum ratings (Ta=25 °C)

Parameter	Symbol	Value	Unit
Supply voltage	Vcc	-0.5 to +7	V
Output current	Io	20	mA
Power dissipation *1	Po	250	mW
Operating temperature	Topr	-30 to +80	°C
Storage temperature	Tstg	-40 to +85	°C
Soldering	-	230 °C, 5 s, at least 1.8 mm away from package surface	

*1: Derate power dissipation at a rate of 3.3 mW/°C above Ta=25 °C

■ Electrical and optical characteristics (Ta =25 °C, Vcc=5 V, unless otherwise noted)

Parameter	Symbol	Condition	Min.	Typ.	Max.	Unit	
Supply voltage	Vcc		4.5	-	5.5	V	
Low level output voltage	VoL	IoL=8 mA	-	0.1	0.4	V	
High level output voltage	VoH	IoH=0 mA	4.5	-	-	V	
Current consumption	ICCL	VOA=VOB= "L"	-	6	12	mA	
	ICCH	VOA=VOB= "H"	-	3	12	mA	
Peak sensitivity wavelength	λp		-	870	-	nm	
Slit movement speed	Vp	Ev=200 lx *2 *3	-	-	10,000	slit/s	
Transfer characteristics	Duty ratio *4	DA	Ev=200 lx *2	35	50	65	%
		DB	f=2.5 kHz				
	Phase difference	θAB	f=2.5 kHz, Ev=200~700 lx *2	60	90	120	deg
Threshold illuminance *5	EVD	"A" light source, f=2.5 kHz	-	30	120	lx	

*2: Ev is illuminance emitted from a CIE standard "A" light source (tungsten lamp).

*3: A collimated light source and a recommended slit moving at a constant speed are used.

[Delay time between the instant that the slit passes through the output transition position and the actual output transition should be less than 1/8 of the slit cycle.]

*4: See next page.

*5: Minimum illuminance from an "A" light source when the duty ratio of phases A and B is between 35 and 65 %.

■ Block diagram

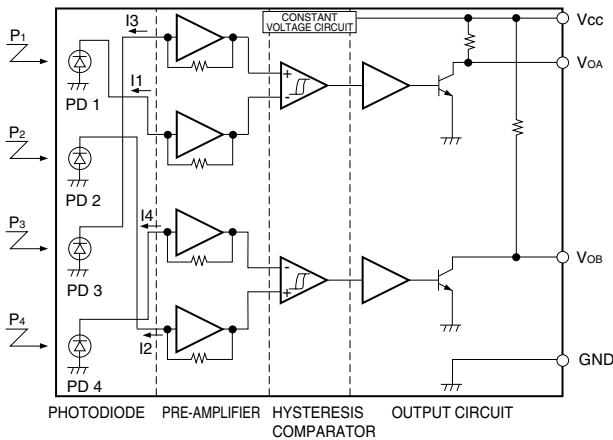

INPUT		OUTPUT	
		V _{OA}	V _{OB}
P ₁ < P ₃	P ₂ > P ₄	L	L
P ₁ < P ₃	P ₂ < P ₄	L	H
P ₁ > P ₃	P ₂ > P ₄	H	L
P ₁ > P ₃	P ₂ < P ₄	H	H

■ Dimensional outline (unit: mm)

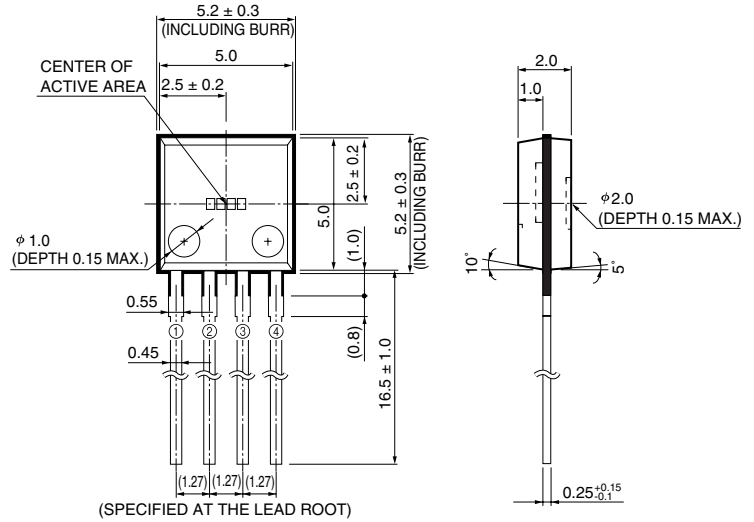

KPIC0012EC

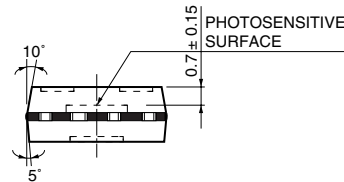

- ① V_{OA}
- ② V_{CC}
- ③ GND
- ④ V_{OB}

Tolerance unless otherwise noted: ±0.1, ±2°
Shaded area indicates burr.
Values in parentheses are not guaranteed, but for reference

KPICA0016EB

■ Details of photodiodes (unit: mm)

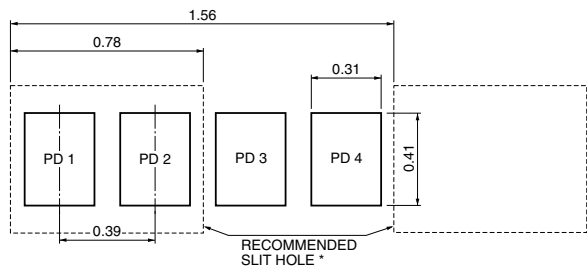

* Recommended slit holes for uniform collimated light

KPIC0013ED

■ Recommended slit (unit: mm)

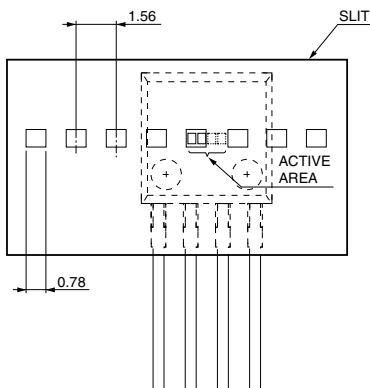

LIGHT SOURCE: COLLIMATED LIGHT LED

KPIC0014EB

■ Operation timing diagram

Outputs V_{OA} and V_{OB} change as shown when the slit is moved to the right at a constant speed from the position shown on the left figure.

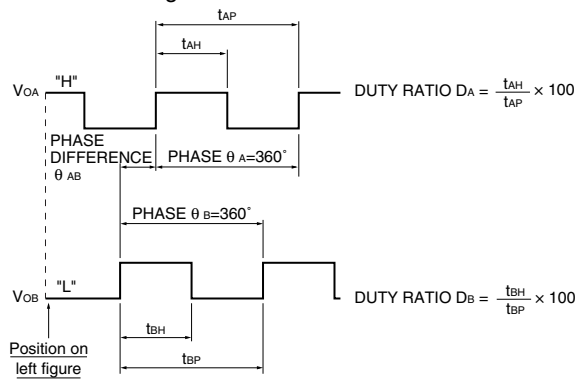

KPIC0015EC