

TOSHIBA Photo-IC Silicon Epitaxial Planar

# TPS853

Mobile Phones, PHS  
 Notebook PCs, PDAs  
 Video cameras, Digital Still Cameras  
 Other Equipment Requiring Luminosity Adjustment

The TPS853 is an ultra-compact surface-mount photo-IC for illuminance sensors which incorporates a photodiode and current amp circuit in a single chip.

The sensitivity is superior to that of a phototransistor, and exhibits little variation.

It has spectral sensitivity closer to luminous efficiency and excellent output linearity.

This photo-IC can be used as the power-saving control for domestic appliances or for backlighting for displays in cellular phones.

This device includes stand-by function which can reduce the power consumption of the system.

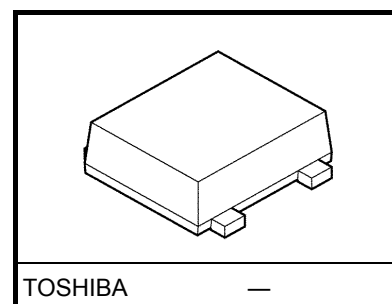

Weight: 0.0054 g (typ.)

- Ultra-compact and light surface-mount package:  $2.0 \times 2.1 \times 0.7$  mm
- Excellent output linearity of illuminance
- Little fluctuation in light current and high level of sensitivity
  - :  $I_L = 37 \mu\text{A}$  to  $74 \mu\text{A}$  @EV = 100 lx using fluorescent light
  - : Light current variation width:  $\times 1.67$  (when light current classification is specified.)
  - : Little temperature fluctuation in light current
- Built-in luminous-efficiency correction function, reduced sensitivity variations due to various light sources
  - :  $I_L$  (using incandescent light)/ $I_L$  (using fluorescent light) = 1.2 (typ.)
- Low supply voltage, making device suitable for battery-powered equipment:  $V_{CC} = 2.2$  V to 5.5 V
- Lead(Pb)-Free

## Absolute Maximum Ratings (Ta = 25°C)

Characteristics	Symbol	Rating	Unit
Supply voltage	$V_{CC}$	-0.5 to 7	V
Output voltage	$V_{OUT}$	$\leq V_{CC}$	V
Stand-by voltage	$V_{stb}$	$\leq V_{CC}$	V
Light current	$I_L$	5	mA
Permissible power dissipation	P	35	mW
Operating temperature range	$T_{opr}$	-30 to 85	°C
Storage temperature range	$T_{stg}$	-40 to 100	°C
Soldering temperature range (Note 1)	$T_{sol}$	260	°C

Note: Using continuously under heavy loads (e.g. the application of high temperature/current/voltage and the significant change in temperature, etc.) may cause this product to decrease in the reliability significantly even if the operating conditions (i.e. operating temperature/current/voltage, etc.) are within the absolute maximum ratings and the operating ranges.

Please design the appropriate reliability upon reviewing the Toshiba Semiconductor Reliability Handbook ("Handling Precautions"/"Derating Concept and Methods") and individual reliability data (i.e. reliability test report and estimated failure rate, etc).

Note 1: The reflow time and the recommended temperature profile are shown in the section entitled Handling Precautions.

## Operating Ranges

Characteristics	Symbol	Min	Typ.	Max	Unit
Supply voltage	$V_{CC}$	2.2	—	5.5	V
Stand-by voltage	$V_{stb}$	2.2	—	$V_{CC}$	V

## Electrical and Optical Characteristics (Ta = 25°C)

Characteristics	Symbol	Test Condition	Min	Typ.	Max	Unit
Supply voltage	V <sub>CC</sub>	—	2.2	—	5.5	ϕ
Supply current (1)	I <sub>CC</sub> +I <sub>stb</sub> (1) (Note 6)	V <sub>CC</sub> = 3 V, V <sub>stb</sub> = 3 V, E <sub>V</sub> = 1000 lx R <sub>L</sub> = 1 kΩ (Note 2)	—	624	—	μA
Supply current (2)	I <sub>CC</sub> +I <sub>stb</sub> (2) (Note 6)	V <sub>CC</sub> = 3 V, V <sub>stb</sub> = 0.3 V, E <sub>V</sub> = 1000 lx R <sub>L</sub> = 1 kΩ (Note 2)	—	4.2	—	μA
Light current (1)	I <sub>L</sub> (1)	V <sub>CC</sub> = 3 V, V <sub>stb</sub> = 3 V, E <sub>V</sub> = 100 lx (Note 2), (Note 4)	—	62	—	μA
Light current (2)	I <sub>L</sub> (2)	V <sub>CC</sub> = 3 V, V <sub>stb</sub> = 3 V, E <sub>V</sub> = 10 lx (Note 3), (Note 4)	3.7	5.2	7.4	μA
Light current (3)	I <sub>L</sub> (3)	V <sub>CC</sub> = 3 V, V <sub>stb</sub> = 3 V, E <sub>V</sub> = 100 lx (Note 3), (Note 4)	37	52	74	μA
Light current ratio	$\frac{I_L (1)}{I_L (3)}$	—	—	1.2	1.7	
Dark current	I <sub>LEAK</sub>	V <sub>CC</sub> = 3.3 V, V <sub>stb</sub> = 3.3V, E <sub>V</sub> = 0	—	—	0.1	μA
Saturation output voltage	V <sub>O</sub>	V <sub>CC</sub> = 3 V, V <sub>stb</sub> = 3 V, R <sub>L</sub> = 150 kΩ, E <sub>V</sub> = 100 lx (Note 3)	2.2	2.35	—	V
Peak sensitivity wavelength	λ <sub>p</sub>	—	—	600	—	nm
Switching time	Rise time	V <sub>CC</sub> = 3 V, V <sub>stb</sub> = 3 V, R <sub>L</sub> = 5 kΩ  (Note 5)	—	0.07	1	ms
	Fall time		—	0.4	2	

Note 2: CIE standard A light source is used (color temperature = 2856K, approximated incandescence light).

Note 3: Fluorescence light is used as light source. However, white LED is substituted in a mass-production process.  
I<sub>L</sub> classification I<sub>L</sub> (3) → A: 39 μA to 65 μA

Note 4: Light current measurement circuit

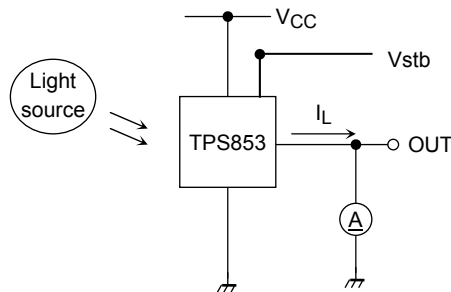

Note 5: Rise time/fall time time measurement method

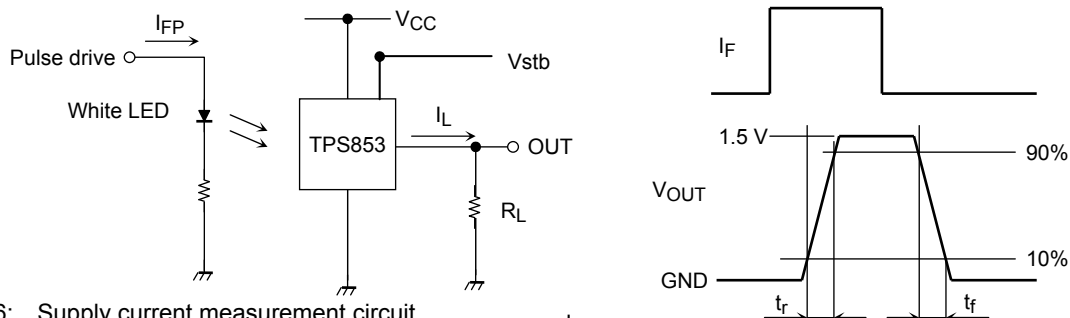

Note 6: Supply current measurement circuit

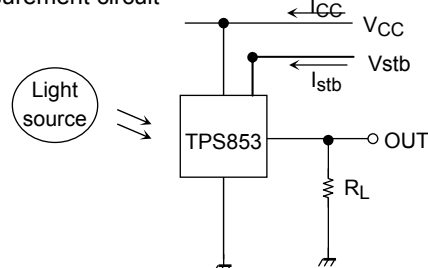



**Handling Precautions**

Insert a bypass condenser of up to 0.1μF between Vcc and GND near the device to stabilize the power supply line. When Vcc is turned on it takes at least 100 ms for the internal circuit to stabilize. During this time the output signal is unstable. Please do not use the unstable signal as the output signal.

**Moisture-Proof Packing**

- (1) To avoid moisture absorption by the resin, the product is packed in an aluminum envelope with silica gel.
- (2) Since the optical characteristics of the device can be affected during soldering by vaporization resulting from prior absorption of moisture and they should therefore be stored under the following conditions:  
 Temperature: 5°C to 30°C, Relative humidity: 70% (max), Time: 168 h (max)
- (3) Baking is required if the devices have been store unopened for more than six months or if the aluminum envelope has been opened for more than 168 h.  
 These devices are packed on tapes; hence, please avoid baking at high temperature.  
 Recommended baking conditions: 60°C for 12 h or longer

**Mounting Precautions**

TPS853 uses a clear resin, and delicate handling is necessary for it. The characteristic change or the product might be damaged by the handling method of mounting. Please note the following and handle the product.

- (1) Do not apply stress to the resin at high temperature.  
 Time until the product returns at the normal temperature after mounting of the reflow is different according to the mounting substrate and the environment.  
 Please do not give the stress with heat remained in the product.
- (2) The resin part is easily scratched, so avoid friction with hard materials.
- (3) When installing the assembly board in equipment, ensure that this product does not come into contact with other components.
- (4) Please confirm the heat contraction of the substrate of the reflow mounting doesn't influence the product. The load is given to the product by mounting that the heat contraction is large on the substrate and the installation position of the substrate. Please note that the characteristic changes or the product might be damaged.

**Mounting Methods**

- (1) Example of reflow soldering

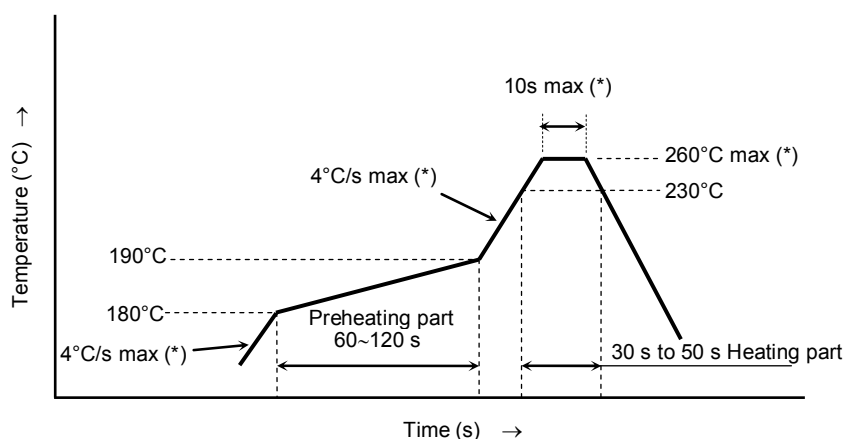

(\*)The product is evaluated using above reflow soldering conditions. No additional test is performed exceed the condition (i.e. the condition more than MAX values) as an evaluation. Please perform reflow soldering under the above conditions. Perform reflow soldering no more than twice.

- Please perform the first reflow soldering within 168 h after opening the package with reference to the above temperature profile.

- Second reflow soldering  
 In case of second reflow soldering, it should be performed within 168 h after first reflow under the above conditions.  
 Storage conditions before second reflow soldering: 30°C, 70% RH or lower
- Do not perform flow soldering.
- Make any necessary soldering correction manually.  
 (do not do this more than once for any given pin.)  
 Temperature: no more than 350°C (25 W for soldering iron)  
 Time: within 5 s

(2) Recommended soldering pattern

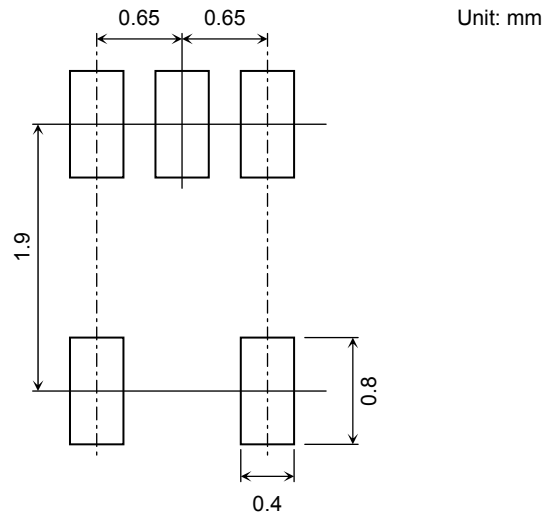

(3) Cleaning conditions

- When cleaning is required after soldering
  - Chemicals: AK225 alcohol
  - Temperature and time: 50°C × 30 s or 30°C × 3 minutes
  - Ultrasonic cleaning: 300 W or less

**Packing Specification**

(1) Packing quantity

Reel (minimum packing quantity)	3,000 devices
Carton	5 reels (15,000 devices)

(2) Packing format

An aluminum envelope containing silica gel and reels is deaerated and sealed.  
 Pack shock-absorbent materials around the aluminum envelopes in the cartons to cushion them.

- Carton specification

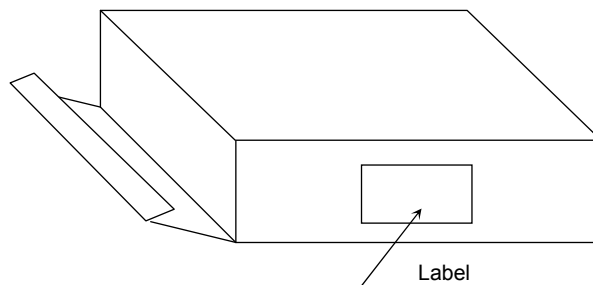

Carton dimensions  
 (W) 81 mm × (L) 280 mm × (H) 280 mm

## Tape Packing Specifications

(1) Reel dimensions

Reel material: Plastic

Unit: mm

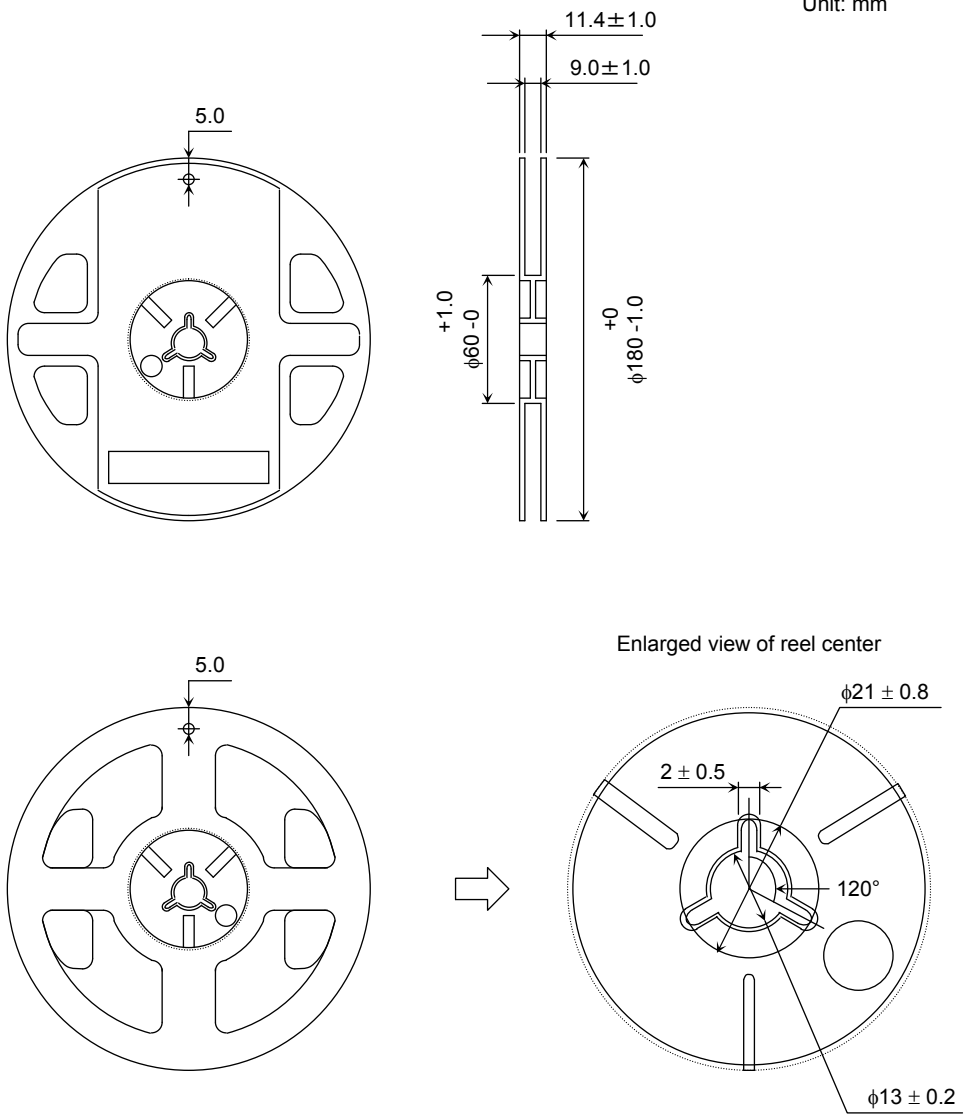

(2) Tape dimensions  
Tape material: Plastic (anti-electrostatic)

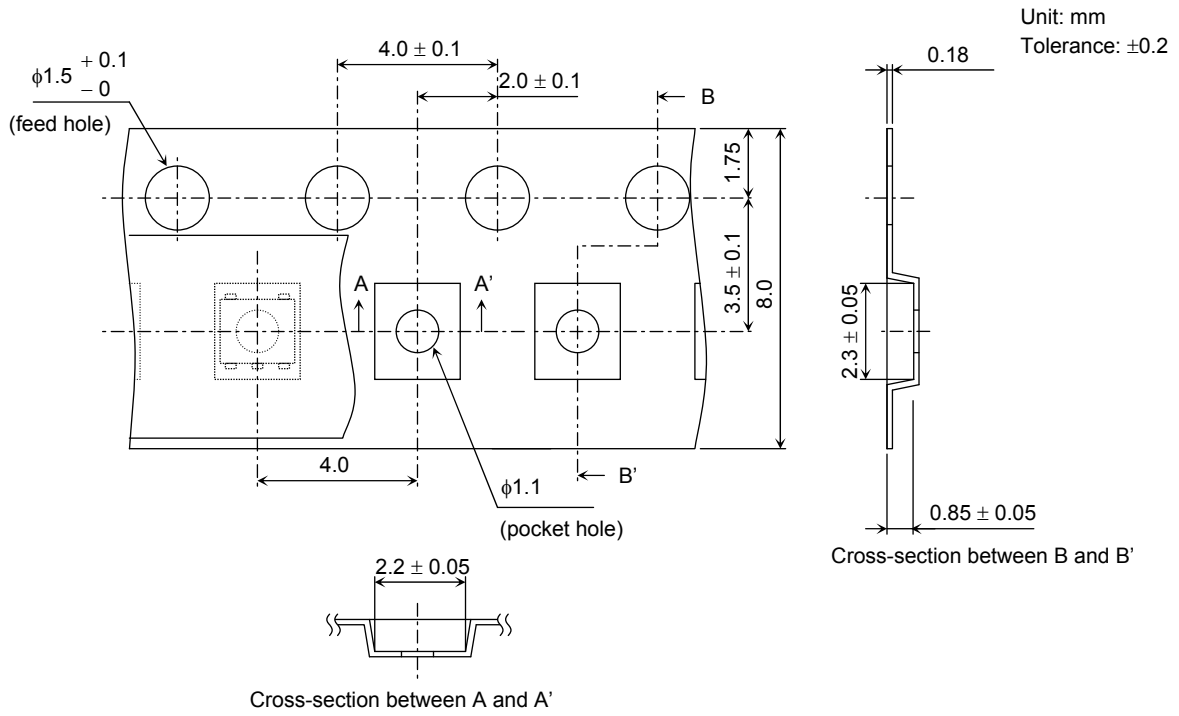

**Reel Label**

The label markings may include product number, tape type and quantity.

P/N

TYPE	TPS853		
ADDC		Q'TY	3,000 pcs.
NOTE			

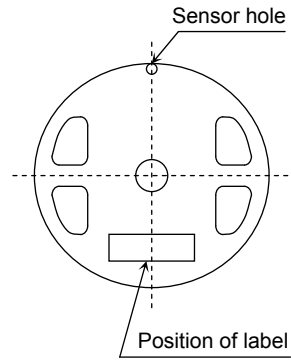

**Leader and Trailer Sections of Tape**

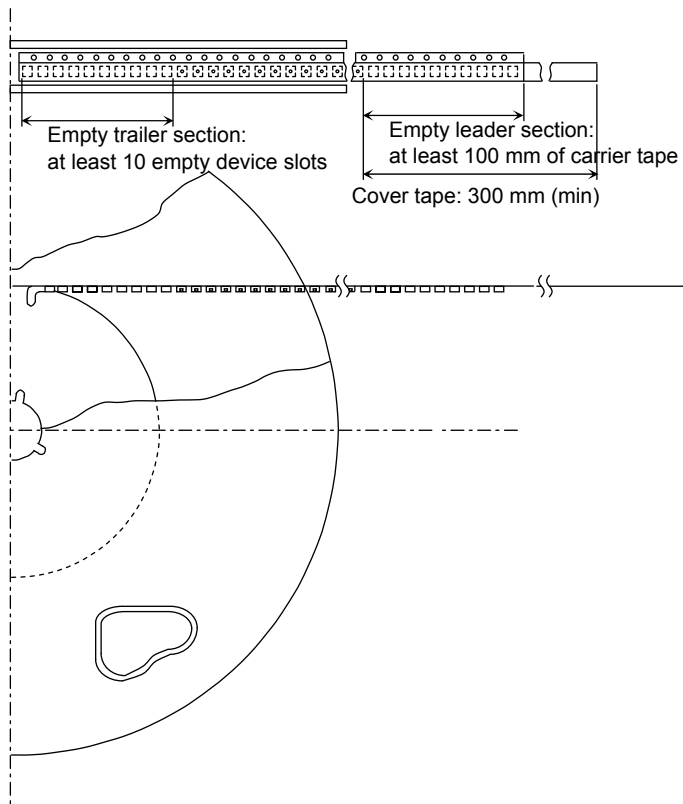



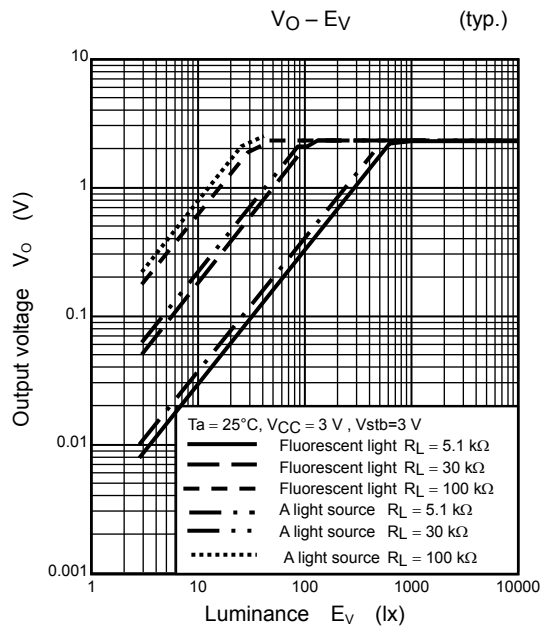
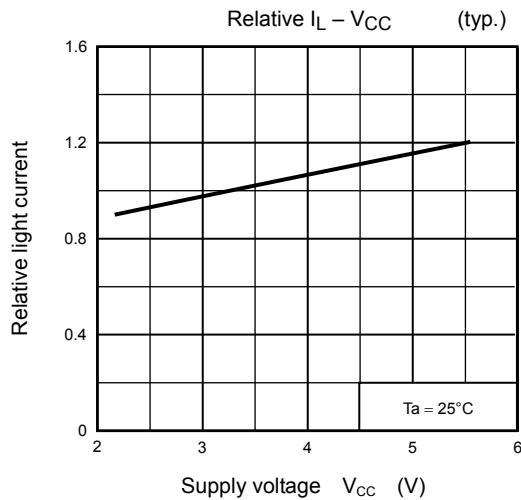
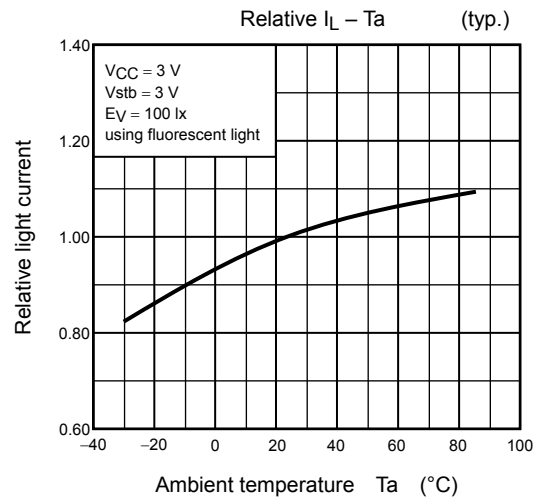
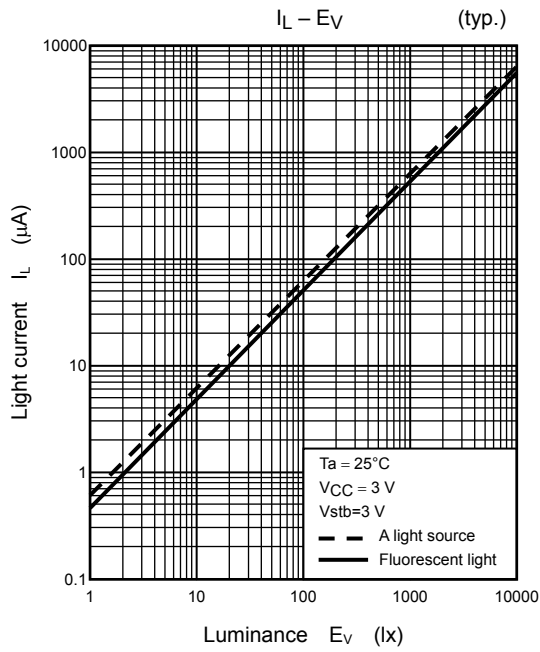
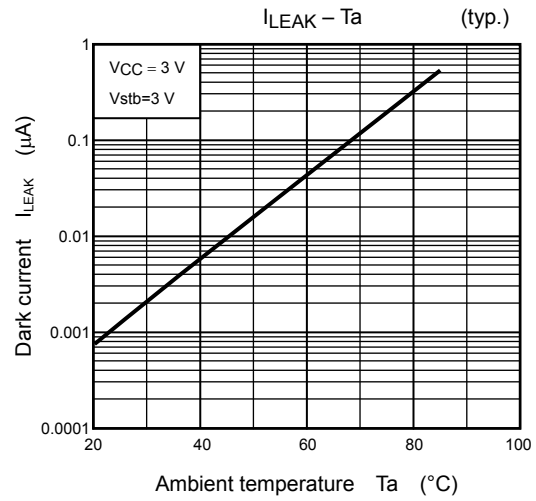
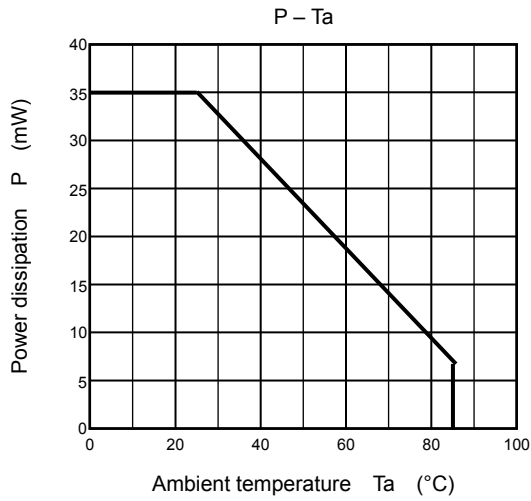

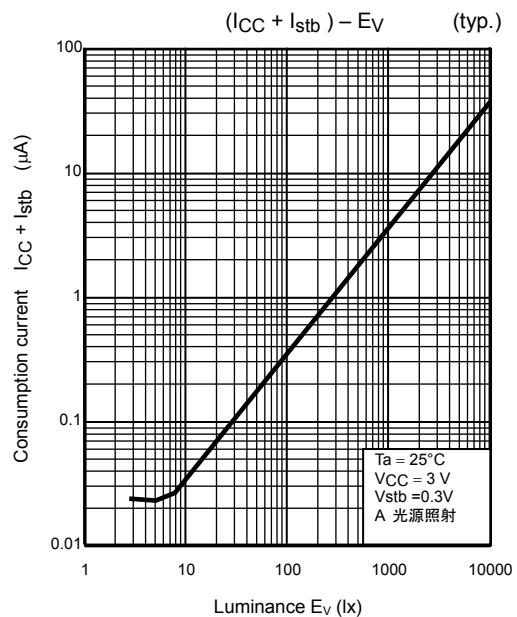
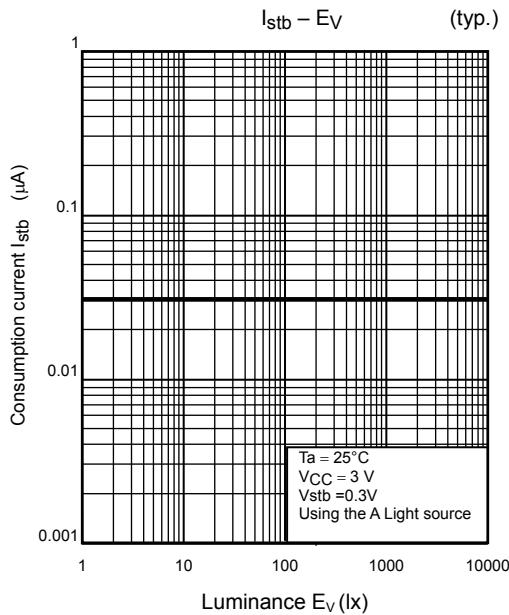
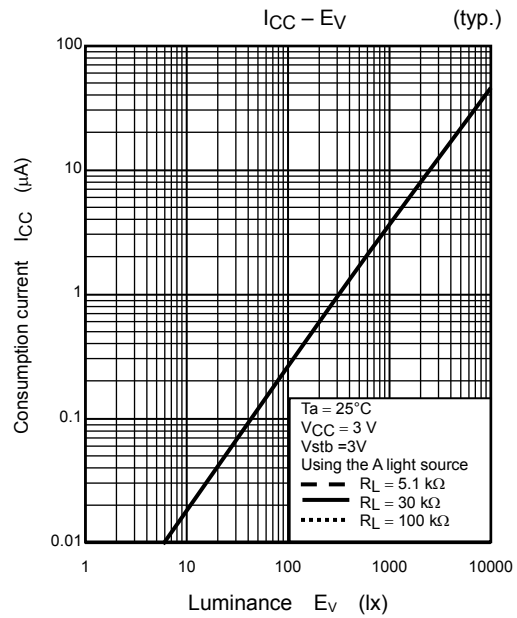
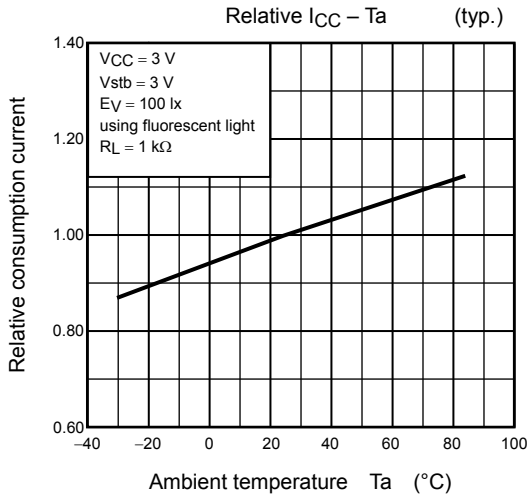
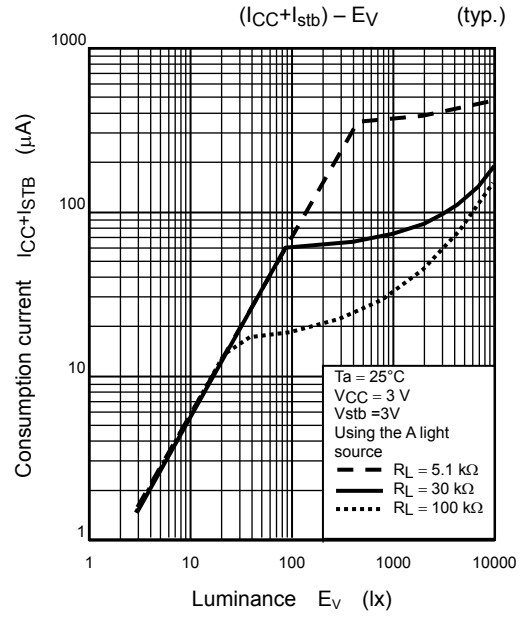
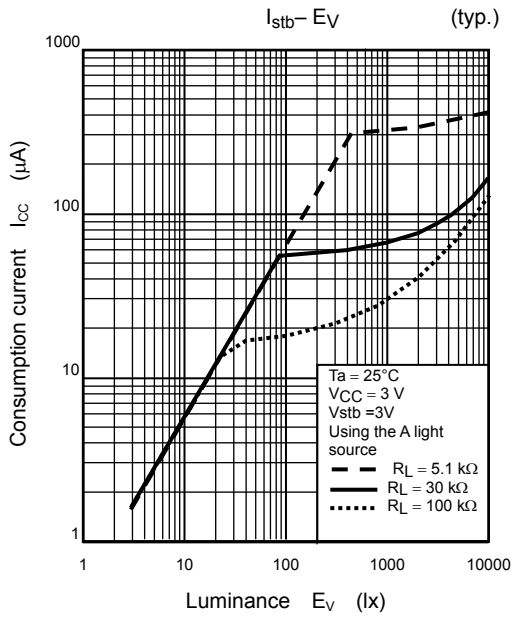

Switching Characteristics  
(non-saturating operation)

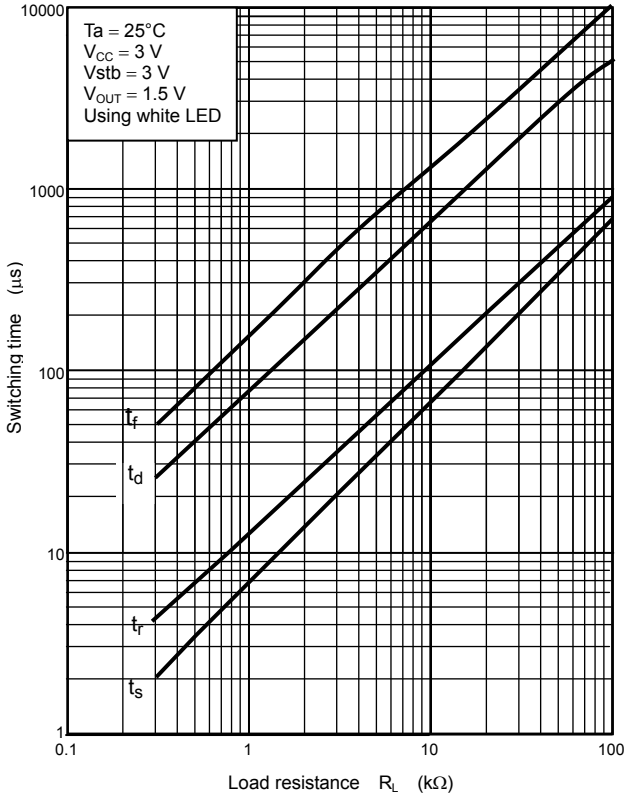

Switching Characteristics  
(saturating operation)

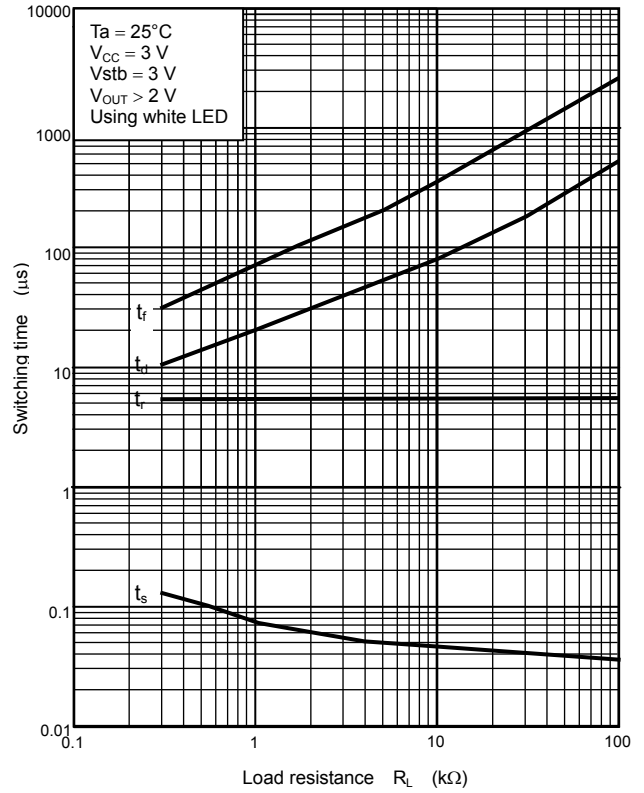

Spectral Response (typ.)

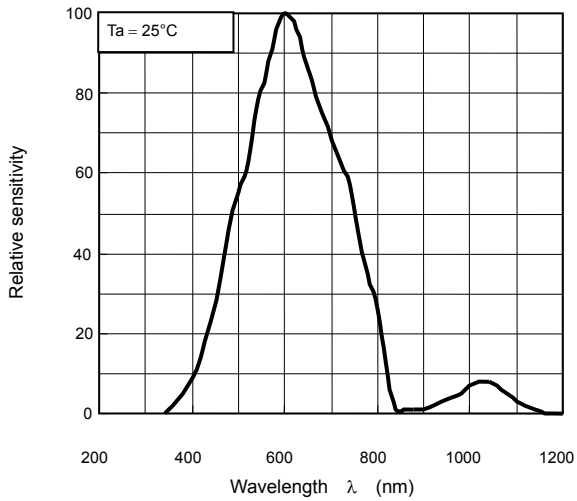

Radiation Pattern (typ.)  
 $T_a = 25^\circ\text{C}$

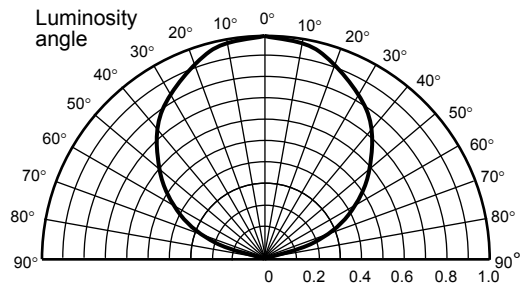

**RESTRICTIONS ON PRODUCT USE**

20070701-EN GENERAL

- The information contained herein is subject to change without notice.
- TOSHIBA is continually working to improve the quality and reliability of its products. Nevertheless, semiconductor devices in general can malfunction or fail due to their inherent electrical sensitivity and vulnerability to physical stress. It is the responsibility of the buyer, when utilizing TOSHIBA products, to comply with the standards of safety in making a safe design for the entire system, and to avoid situations in which a malfunction or failure of such TOSHIBA products could cause loss of human life, bodily injury or damage to property.  
In developing your designs, please ensure that TOSHIBA products are used within specified operating ranges as set forth in the most recent TOSHIBA products specifications. Also, please keep in mind the precautions and conditions set forth in the "Handling Guide for Semiconductor Devices," or "TOSHIBA Semiconductor Reliability Handbook" etc.
- The TOSHIBA products listed in this document are intended for usage in general electronics applications (computer, personal equipment, office equipment, measuring equipment, industrial robotics, domestic appliances, etc.). These TOSHIBA products are neither intended nor warranted for usage in equipment that requires extraordinarily high quality and/or reliability or a malfunction or failure of which may cause loss of human life or bodily injury ("Unintended Usage"). Unintended Usage include atomic energy control instruments, airplane or spaceship instruments, transportation instruments, traffic signal instruments, combustion control instruments, medical instruments, all types of safety devices, etc.. Unintended Usage of TOSHIBA products listed in this document shall be made at the customer's own risk.
- The products described in this document shall not be used or embedded to any downstream products of which manufacture, use and/or sale are prohibited under any applicable laws and regulations.
- The information contained herein is presented only as a guide for the applications of our products. No responsibility is assumed by TOSHIBA for any infringements of patents or other rights of the third parties which may result from its use. No license is granted by implication or otherwise under any patents or other rights of TOSHIBA or the third parties.
- Please contact your sales representative for product-by-product details in this document regarding RoHS compatibility. Please use these products in this document in compliance with all applicable laws and regulations that regulate the inclusion or use of controlled substances. Toshiba assumes no liability for damage or losses occurring as a result of noncompliance with applicable laws and regulations.