

COMPENSATED AND CALIBRATED LOW PRESSURE SENSOR



**SILICON
MICROSTRUCTURES**
INCORPORATED
Member of the ELMOS Group

Product Number: SM5652

HIGHLIGHTS

- Low pressures for sensitive applications
- Constant voltage driven
- Dual inline package (DIP)
- Fully temperature compensated and calibrated

TYPICAL APPLICATIONS

- Medical equipment
- Respiration
- HVAC
- Level detection
- Flow measurement
- Industrial control

TECHNICAL FEATURES

- 0.15, 0.3, 0.8, 1.5 PSI / 1.0, 2.1, 5.5, 10.3 kPa
- Easy-to-use dual inline package (DIP)
- Zero offset calibration
- High-performance, stable, packaged silicon chip
- Wide 0-60°C compensated temperature range



DESCRIPTION

The SM5600 Series of OEM pressure sensors are laser trimmed for enhanced performance, temperature-compensated, low-pressure sensors in dual in-line packages for printed circuit board mounting. These sensors offer improved performance, as well as the option for constant voltage excitation. With the ability to detect pressure ranges as low as 0.15 PSI, the SM5652 is ideal for applications requiring extreme sensitivity from respiration to air filter obstructions.

The SM5600 Series pressure sensors are constructed by attaching a highly stable piezoresistive pressure sensor chip to a ceramic substrate. Thick film resistors on the ceramic are laser trimmed during manufacturing to provide zero offset calibration, temperature compensation for zero offset, and temperature compensation for sensitivity.

Various pressure port configurations are available for flexibility in matching this product to specific applications.



Product Number: SM5652

ABSOLUTE MAXIMUM RATING TABLE FOR SM5652

All parameters are specified at $V_{SUPPLY} = 10.00\text{ V DC}$ supply at room temperature, unless otherwise noted.

No.	Characteristic	Symbol	Minimum	Typical	Maximum	Units
1	Excitation Voltage	V_{SUPPLY}	0	10	20	V
2	Proof Pressure ^(d)	P_{PROOF}	10x			P_{RANGE}
3	Burst Pressure ^(d)	P_{BURST}	15x			P_{RANGE}
4	Operating Temperature ^(d)	T_{OP}	-40		+125	°C
5	Storage Temperature ^(d)	T_{STG}	-40		+125	°C
6	Media Compatibility ^(d)					

OPERATING CHARACTERISTICS FOR SM5652 - SPECIFICATIONS

All parameters are specified at $V_{SUPPLY} = 10.00\text{ V DC}$ supply at room temperature, unless otherwise noted.

All Pressures	No.	Characteristic	Symbol	Minimum	Typical	Maximum	Units
	7	Zero Offset	V_{ZERO}	-2.0	+0.2	+2.0	mV
	8	Pressure Hysteresis ^(d)	$H_{P,ZERO}$	-0.30	0.05	0.30	%FS
	9	Resistance Input	R_B	4.5	8.0	25.0	k Ω
	10	Resistance Output	$R_{B,OUT}$	2.0	2.5	3.8	k Ω
	11	Compensated Temp. Range ^(c)	T_{COMP}	0		60	°C

0.15 PSI / 1.0 kPa	No.	Characteristic	Symbol	Minimum	Typical	Maximum	Units
	12	Span (FS p_{RANGE}) ^{(a),(b)}	V_{SPAN}	23.75	25.0	26.25	mV
	13	Thermal Accuracy - Span ^(c)	TCS	-2.0	0.2	2.0	% FS
	14	Thermal Accuracy - Zero Offset ^(c)	TCZ	-2.0	0.2	2.0	% FS
	15	Temperature Hysteresis ^(d)	H_T	-0.65	0.05	0.65	%FS
	16	Linearity ^(d)	NL	-2.50	0.05	2.50	%FS
17	Repeatability ^(d)	REP	-0.30	0.05	0.30	%FS	

0.3 PSI / 2.1 kPa	No.	Characteristic	Symbol	Minimum	Typical	Maximum	Units
	18	Span (FS p_{RANGE}) ^{(a),(b)}	V_{SPAN}	24.5	25.0	25.5	mV
	19	Thermal Accuracy - Span ^(c)	TCS	-0.75	0.2	0.75	% FS
	20	Thermal Accuracy - Zero Offset ^(c)	TCZ	-1.0	0.2	1.0	% FS
	21	Temperature Hysteresis ^(d)	H_T	-0.45	0.05	0.45	%FS
	22	Linearity ^(d)	NL	-0.50	0.05	0.50	%FS
23	Repeatability ^(d)	REP	-0.30	0.05	0.30	%FS	

Product Number: SM5652

0.8 PSI / 5.5 kPa & 1.5 PSI / 10.3kPa

No.	Characteristic	Symbol	Minimum	Typical	Maximum	Units
24	Span (FS p_{RANGE}) ^{(a),(b)}	V_{SPAN}	24.5	25.0	25.5	mV
25	Thermal Accuracy - Span ^(c)	TCS	-0.65	0.2	0.65	% FS
26	Thermal Accuracy - Zero Offset ^(c)	TCZ	-1.0	0.2	1.0	% FS
27	Temperature Hysteresis ^(d)	H_T	-0.30	0.05	0.30	%FS
28	Linearity ^(d)	NL	-0.30	0.05	0.30	%FS
29	Repeatability ^(d)	REP	-0.30	0.05	0.30	%FS

NOTES:

- (a) Positive Pressure is defined as entry on the bottom side of the die; gain, during factory calibration, is set using negative pressure.
- (b) Values given for top side.
- (c) Measured over a temperature range of 22°C to 58°C.
- (d) Tested on a sample basis.

QUALIFICATION STANDARDS

→ For qualification specifications, please contact Sales at sales@si-micro.com

Product Number: SM5652

Package Dimensions & Pin-Out

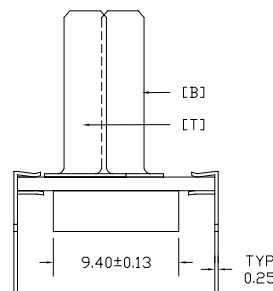
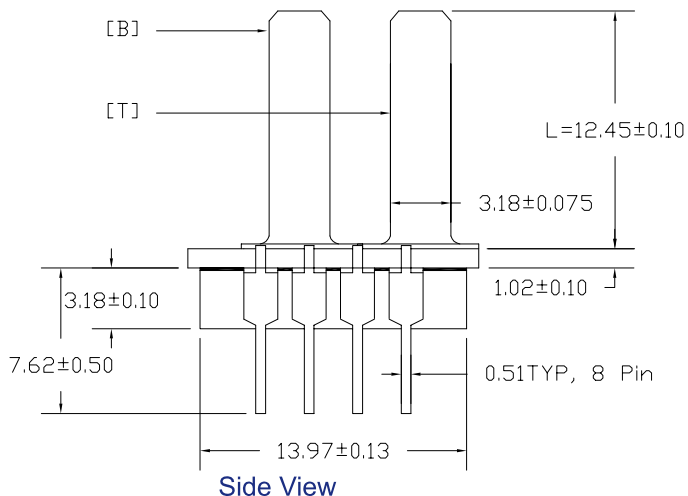

PIN	DESCRIPTION
1	Sig-
2	-Vexc
3	Sig+
4	+Vexc
5	NC
6	NC
7	NC
8	NC

All dimensions are shown in millimeters

NOTES:

- Do not connect to NC pins.
- External connections to NC pins will cause part malfunction.
- Tolerance on all dimensions ± 0.13 mm unless otherwise specified.
- [B] is tube connected to bottom side of sensor die.
- [T] is tube connected to top side of sensor die.
- Tube [B] is used for positive differential pressure.

Pin Configuration

- Pins opposite direction of tube

Tube Length

- L: Long (12.45 mm \pm 0.10 mm)
- S: Short (8.25 mm \pm 0.10 mm)

Pressure Type

- D: Differential (2 Tubes)
- G: Gauge (1 Tube, [B] tube only)

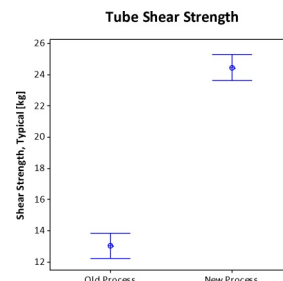
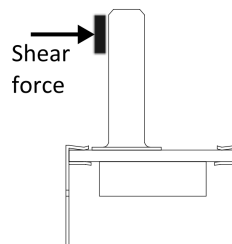
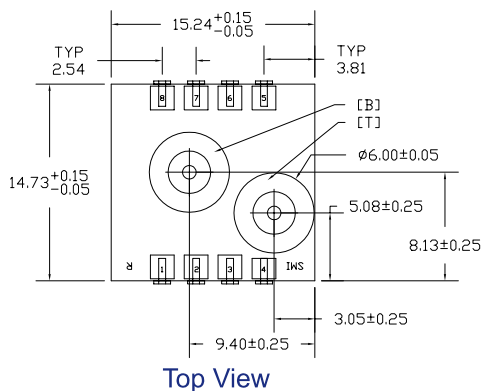

Ordering information

Order Code	Pressure Type	Full-Scale Pressure Range	Tube Length
5652-001-D-3-LR	Differential	0.15 PSI / 1.0 kPa	Long
5652-001-D-3-SR	Differential	0.15 PSI / 1.0 kPa	Short
5652-003-D-3-LR	Differential	0.3 PSI / 2.1 kPa	Long
5652-003-D-3-SR	Differential	0.3 PSI / 2.1 kPa	Short
5652-003-G-3-SR	Gauge	0.3 PSI / 2.1 kPa	Short
5652-008-G-3-SR	Gauge	0.8 PSI / 5.5 kPa	Short
5652-015-D-3-LR	Differential	1.5 PSI / 10.3 kPa	Long
5652-015-D-3-SR	Differential	1.5 PSI / 10.3 kPa	Short

For samples, please contact sales@si-micro.com.

Product Number: SM5652

Silicon Microstructures Warranty and Disclaimer:

Silicon Microstructures, Inc. reserves the right to make changes without further notice to any products herein and to amend the contents of this data sheet at any time and at its sole discretion.

Information in this document is provided solely to enable software and system implementers to use Silicon Microstructures, Inc. products and/or services. No express or implied copyright licenses are granted hereunder to design or fabricate any silicon-based microstructures based on the information in this document.

Silicon Microstructures, Inc. makes no warranty, representation, or guarantee regarding the suitability of its products for any particular purpose, nor does Silicon Microstructures, Inc. assume any liability arising out of the application or use of any product or silicon-based microstructure, and specifically disclaims any and all liability, including without limitation consequential or incidental damages. "Typical" parameters which may be provided in Silicon Microstructure's data sheets and/or specifications can and do vary in different applications and actual performance may vary over time. All operating parameters, including "Typicals", must be validated for each customer application by customer's technical experts. Silicon Microstructures, Inc. does not convey any license under its patent rights nor the rights of others. Silicon Microstructures, Inc. makes no representation that the circuits are free of patent infringement. Silicon Microstructures, Inc. products are not designed, intended, or authorized for use as components in systems intended for surgical implant into the body, or other applications intended to support or sustain life, or for any other application in which the failure of the Silicon Microstructures, Inc. product could create a situation where personal injury or death may occur. Should Buyer purchase or use Silicon Microstructures, Inc. products for any such unintended or unauthorized application, Buyer shall indemnify and hold Silicon Microstructures, Inc. and its officers, employees, subsidiaries, affiliates, and distributors harmless against all claims, costs, damages, and expenses, and reasonable attorney fees arising out of, directly or indirectly, any claim of personal injury or death associated with such unintended or unauthorized use, even if such claim alleges that Silicon Microstructures, Inc. was negligent regarding the design or manufacture of the part.

Silicon Microstructures, Inc. warrants goods of its manufacture as being free of defective materials and faulty workmanship. Silicon Microstructures, Inc. standard product warranty applies unless agreed to otherwise by Silicon Microstructures, Inc. in writing; please refer to your order acknowledgement or contact Silicon Microstructures, Inc. directly for specific warranty details. If warranted goods are returned to Silicon Microstructures, Inc. during the period of coverage, Silicon Microstructures, Inc. will repair or replace, at its option, without charge those items it finds defective. The foregoing is buyer's sole remedy and is in lieu of all warranties, expressed or implied, including those of merchantability and fitness for a particular purpose. In no event shall Silicon Microstructures, Inc. be liable for consequential, special, or indirect damages.

While Silicon Microstructures, Inc. provides application assistance personally, through its literature and the Silicon Microstructures, Inc. website, it is up to the customer to determine the suitability of the product for its specific application. The information supplied by Silicon Microstructures, Inc. is believed to be accurate and reliable as of this printing. However, Silicon Microstructures, Inc. assumes no responsibility for its use. Silicon Microstructures, Inc. assumes no responsibility for any inaccuracies and/or errors in this publication and reserves the right to make changes without further notice to any products or specifications herein

Silicon Microstructures, Inc.™ and the Silicon Microstructures, Inc. logo are trademarks of Silicon Microstructures, Inc. All other service or product names are the property of their respective owners.

© Silicon Microstructures, Inc. 2001-2010. All rights reserved.