

OV511⁺

Advanced Camera to USB Bridge
OmniVision Technologies, Inc.
May 13, 2000

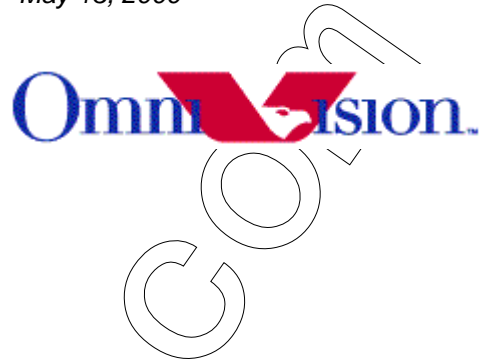

Data Sheet Rev. 1.2

OmniVision Technologies, Inc. reserves the right to make changes without further notice to any product herein to improve reliability, function or design. OmniVision does not assume any liability arising out of the application or use of any project, circuit described herein; neither does it convey any license under its patent nor the right of others.

This document contains information of a proprietary nature. None of this information shall be divulged to persons other than OmniVision Technologies, Inc. employee authorized by the nature of their duties to receive such information, or individuals or organizations authorized by OmniVision Technologies, Inc.

Content

1	Features.....	4
2	Architecture.....	5
2.1	General Description	5
2.2	Functional Description.....	6
2.2.1	Camera Interface.....	6
2.2.2	DRAM Interface.....	7
2.2.3	OmniCE.....	8
2.2.4	ISO FIFO	9
2.2.5	UDC interface	10
2.2.6	System Control.....	10
2.2.7	USB Device Controller.....	11
2.2.8	SCCB (Serial Camera Control Bus).....	11
2.2.9	PIO	11
2.2.10	Custom ID.....	13
3	Pin Definition.....	14
3.1	Pin Assignments	14
3.2	Pin Descriptions.....	15
4	Electrical Characteristics	17
5	Register Table (Vendor Commands).....	18
5.1	CAMERA INTERFACE.....	18
5.2	DRAM INTERFACE.....	19
5.3	ISO FIFO.....	19
5.4	PIO.....	20
5.5	SCCB	20
5.6	SYSTEM CONTROL.....	22
5.7	OmniCE	23
6	USB Descriptors.....	24
6.1	Device.....	24
6.2	Configuration.....	24
6.3	Interface & Endpoint	24
6.3.1	Alternate 0	25
6.3.2	Alternate 1	25
6.3.3	Alternate 2	25
6.3.4	Alternate 3	26
6.3.5	Alternate 4	26
6.3.6	Alternate 5	27
6.3.7	Alternate 6	27
6.3.8	Alternate 7.....	27
7	Software Package.....	29
8	Mechanical Information	30

Illustrations

FIGURE 1.	FUNCTIONAL BLOCK DIAGRAM.....	5
FIGURE 2.	CAMERA INTERFACE YUV - 4:2:2 - 16-BIT HORIZONTAL TIMING WAVEFORMS.....	6
FIGURE 3.	CAMERA INTERFACE VERTICAL – INTERLACE TIMING WAVEFORMS.....	6
FIGURE 4.	CAMERA INTERFACE VERTICAL – PROGRESSIVE TIMING WAVEFORMS.....	7
FIGURE 5.	MEMORY MAP	7
FIGURE 6.	DRAM INTERFACE WRITE CYCLE TIMING WAVEFORMS	7
FIGURE 7.	DRAM INTERFACE READ CYCLE TIMING WAVEFORM.....	8
FIGURE 8.	DRAM INTERFACE REFRESH CYCLE TIMING WAVEFORMS.....	8
FIGURE 9.	STRUCTURE OF OMNICE.....	9
FIGURE 10.	SOF/EOF FORMATS.....	9
FIGURE 11.	CLOCK SCHEME OF OV511 ⁺	10
FIGURE 12.	USB COMMUNICATION FLOW.....	11
FIGURE 13.	PIO READ CYCLE TIMING WAVEFORMS	12
FIGURE 14.	PIO WRITE CYCLE TIMING WAVEFORMS	12
FIGURE 15.	100-PIN PQFP PACKAGE.....	14

Tables

TABLE 1.	CAPABILITY OF CAMERA INTERFACE	6
TABLE 2.	MAXIMUM PIXEL COUNT OF ONE 256KX16 DRAM	6
TABLE 3.	PARAMETERS OF DRAM INTERFACE TIMING	8
TABLE 4.	PARAMETERS OF PIO TIMING	13
TABLE 5.	PIN DESCRIPTIONS	15
TABLE 6.	DC ELECTRICAL CHARACTERISTICS	17
TABLE 7.	ABSOLUTE MAXIMUM RATINGS	17
TABLE 8.	RECOMMENDED OPERATING CONDITIONS	17
TABLE 9.	USB DC ELECTRICAL CHARACTERISTICS	17
TABLE 10.	USB FULL SPEED OUTPUT DRIVER ELECTRICAL CHARACTERISTICS	17
TABLE 11.	CAMERA INTERFACE REGISTER LIST	18
TABLE 12.	DRAM INTERFACE REGISTER LIST	19
TABLE 13.	ISO FIFO REGISTER LIST	19
TABLE 14.	PIO REGISTER LIST	20
TABLE 15.	SCCB REGISTER LIST	20
TABLE 16.	SYSTEM CONTROL REGISTER LIST	22
TABLE 17.	OMNICE REGISTER LIST	23
TABLE 18.	DEVICE DESCRIPTOR LIST	24
TABLE 19.	CONFIGURATION DESCRIPTOR LIST	24
TABLE 20.	INTERFACE DESCRIPTOR LIST OF ALTERNATE 0	25
TABLE 21.	ENDPOINT DESCRIPTOR LIST OF ALTERNATE 0, PACKET SIZE 0	25
TABLE 22.	INTERFACE DESCRIPTOR LIST OF ALTERNATE 1	25
TABLE 23.	ENDPOINT DESCRIPTOR LIST OF ALTERNATE 1, PACKET SIZE 33	25
TABLE 24.	INTERFACE DESCRIPTOR LIST OF ALTERNATE 2	25
TABLE 25.	ENDPOINT DESCRIPTOR LIST OF ALTERNATE 2, PACKET SIZE 129	26
TABLE 26.	INTERFACE DESCRIPTOR LIST OF ALTERNATE 3	26
TABLE 27.	ENDPOINT DESCRIPTOR LIST OF ALTERNATE 3, PACKET SIZE 257	26
TABLE 28.	INTERFACE DESCRIPTOR LIST OF ALTERNATE 4	26
TABLE 29.	ENDPOINT DESCRIPTOR LIST OF ALTERNATE 4, PACKET SIZE 385	26
TABLE 30.	INTERFACE DESCRIPTOR LIST OF ALTERNATE 5	27
TABLE 31.	ENDPOINT DESCRIPTOR LIST OF ALTERNATE 5, PACKET SIZE 513	27
TABLE 32.	INTERFACE DESCRIPTOR LIST OF ALTERNATE 6	27
TABLE 33.	ENDPOINT DESCRIPTOR LIST OF ALTERNATE 6, PACKET SIZE 769	27
TABLE 34.	INTERFACE DESCRIPTOR LIST OF ALTERNATE 7	27
TABLE 35.	ENDPOINT DESCRIPTOR LIST OF ALTERNATE 7, PACKET SIZE 961	28

1 Features

- Low cost, integrated solution for USB PC camera applications
- Built-in USB transceiver with selectable external USB transceiver interface
- USB compliance current consumption in unconfigured, configured, suspend & operating modes
- USB full speed signaling bit rate
- USB high powered, bus powered device
- Supports USB control and isochronous pipes
- Supports 8 isochronous interface alternates of up to 7.5Mbps USB transfer rate
- 256Kx16, 5V, EDO, CAS-BEFORE-RAS refresh, 60ns DRAM required
- Camera Interface: 16-bit YUV 4:2:2/RGB raw data formats (two channels) or 8-bit Y 4:0:0/RGB raw data formats (one channel only)
- Supports clamping, down-scaling & filtering circuits for different video formats (VGA/SIF/QSIF or CIF/SIF/QCIF/QSIF)
- Supports proprietary real-time compression engine of up to 8:1 (10~15fps at VGA)
- VGA resolution uncompressed still image with snapshot button
- Supports SCCB (Serial Camera Control Bus) master function running at 100KHz (normal mode)
- Supports programmable LED control
- Supports programmable switching power clock with frequencies of 24K/48K/96K/192KHz

2 Architecture

2.1 General Description

OV511⁺ based on OV511, is a low cost and highly integrated solution for USB/PC camera applications. It remains OV511's performance unchanged or is improved, while some new features were implemented. New features include built-in USB transceiver with selectable external USB transceiver interface, more effective packet size of the isochronous pipe, programmable LED control, programmable switching power clock with frequencies of 24K/48K/96K/192KHz, etc.

OV511⁺ is a USB/PC camera controller that includes a proprietary compression engine supporting real time image transfer through USB bus. A complete USB/camera system consists of OV511⁺, a 256Kx16 EDO DRAM, and a digital camera such as OV7620 for VGA resolution or OV6620 for CIF resolution.

Camera Interface generates different image formats by taking either 16-bit YUV 4:2:2/RGB raw data or 8-bit Y 4:0:0/RGB raw data inputs. OmniCE is the proprietary compression engine. It not only performs 10~15fps for VGA and 30fps for CIF, but also allows very fast decompression with low CPU utilization. Depending on the camera device that is built with the system, either SCCB or Parallel IO bus can be chosen. The SCCB bus master uses two dedicated pins "SIO-0" & "SIO-1", while the PIO shares with Y & UV buses. Snapshot button allows users to take a high quality, VGA resolution uncompressed still image.

The functional blocks of OV511⁺, as shown in the following figure, consist of Camera Interface, DRAM Interface, OmniCE, UDC interface, ISO FIFO, System Control, SCCB and PIO.

Figure 1. Functional Block Diagram

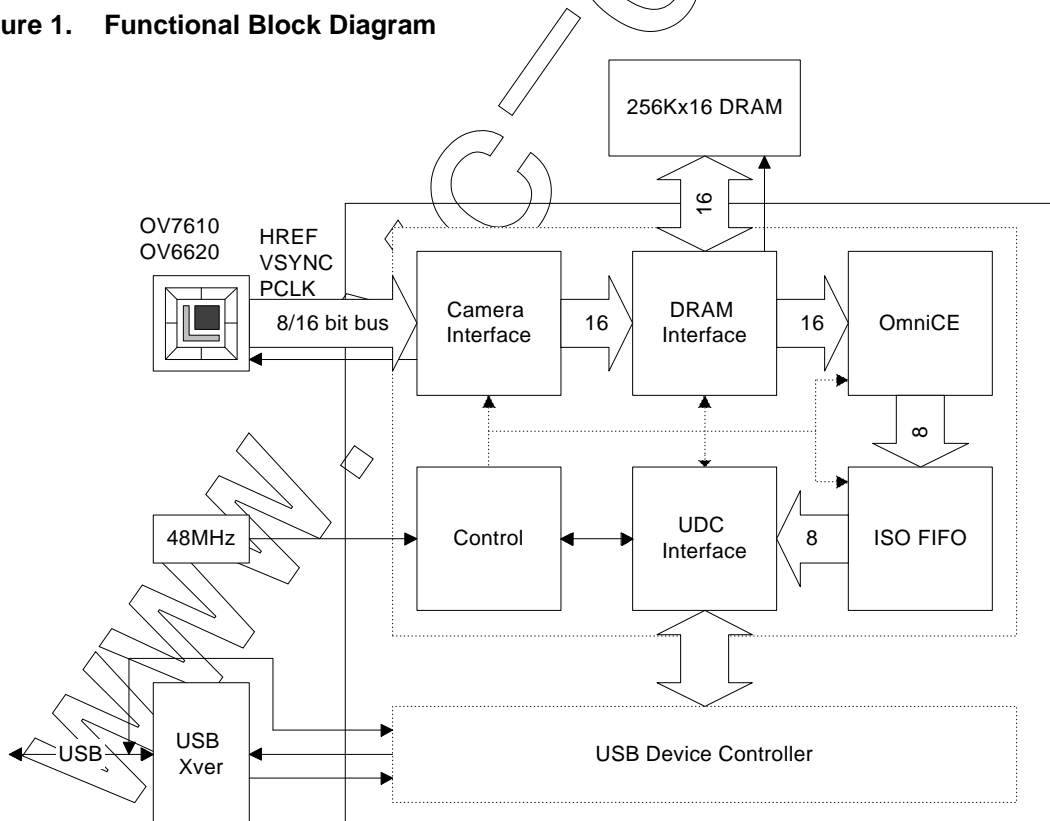

2.2 Functional Description

2.2.1 Camera Interface

OV511+ digital video inputs are either 16-bit YUV 4:2:2/RGB raw data formats (two channels) or 8-bit Y 4:0:0/RGB raw data formats (one channel only). Clamping, downscaling & filtering functions are also supported by Camera Interface. However, it doesn't guarantee that all input formats can be compressed by OmniCE.

Table 1. Capability of Camera Interface

Channels	Input Formats	Clamping	Down-Scaling	Filtering	Compression (OmniCE)
2, 16-bit (Y & UV)	YUV 4:2:2	Available	Available	Available	Available
	16-bit RGB raw	Available	Available	Available	Not available
1, 8-bit (Y only)	Y 4:0:0	Available	Available	Available	Available
	8-bit RGB raw	Available	Available	Not available	Not available

If the camera input format is 16-bit YUV 4:2:2 mode, the output of the camera interface can be configured as YUV 4:2:0 or 4:0:0, as well as YUV 4:2:2.

The maximum clamped image size is 1024 pixels wide and 1024 lines height in increment of 8, depending on the camera input format. The actual image size is limited by the capability of DRAM.

Table 2. Maximum Pixel Count of one 256KX16 DRAM

Output Formats of Camera Interface	Pixel Count
YUV 4:2:2	256K
YUV 4:2:0	344K
Y 4:0:0	512K

The downscaling function sub-samples the image in both horizontal & vertical directions by choosing scaling factor 1, 2, 4 or 8. No up-scaling feature is implemented.

The anti-aliasing filter decimates downscaling images to get rid of alias and improve image quality.

Figure 2. Camera Interface YUV - 4:2:2 - 16-bit Horizontal Timing Waveforms

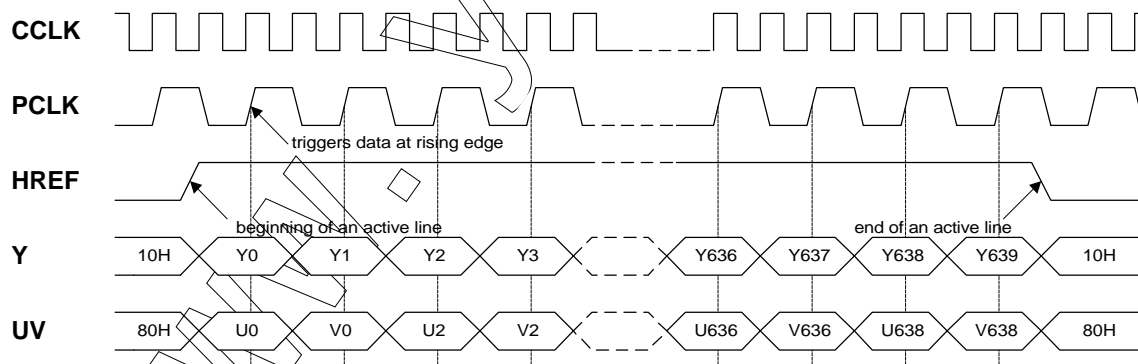

Figure 3. Camera Interface Vertical – Interlace Timing Waveforms

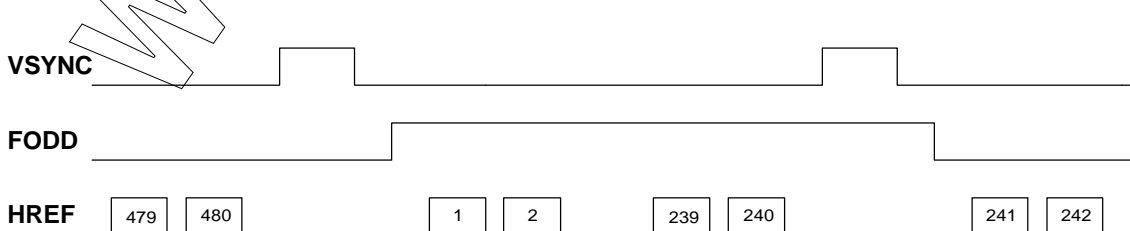
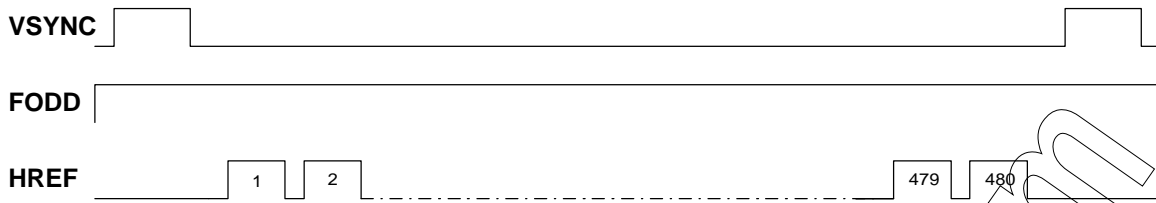

Figure 4. Camera Interface Vertical – Progressive Timing Waveforms



2.2.2 DRAM Interface

DRAM interface generates DRAM addresses for Write and Read cycles based on the configured image size and data format. External DRAM is partitioned according to the data formats such as 4:2:2, 4:2:0 or 4:0:0.

DRAM interface also arbitrates the DRAM access between write request from the camera interface and read request from OmniCE. It also performs the flow control to avoid image overflow and underflow conditions occurred.

OV511⁺ supports 5V EDO, CAS-BEFORE-RAS refresh, 60ns DRAM.

Figure 5. Memory Map

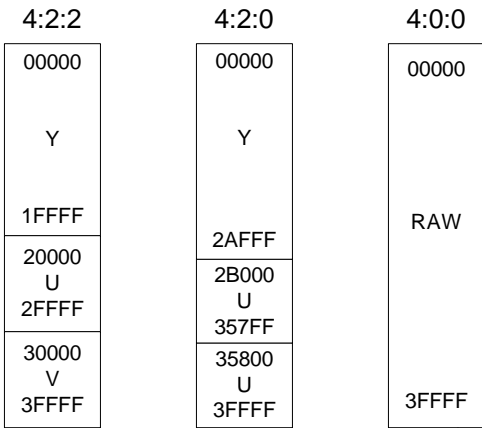

Figure 6. DRAM Interface Write Cycle Timing Waveforms

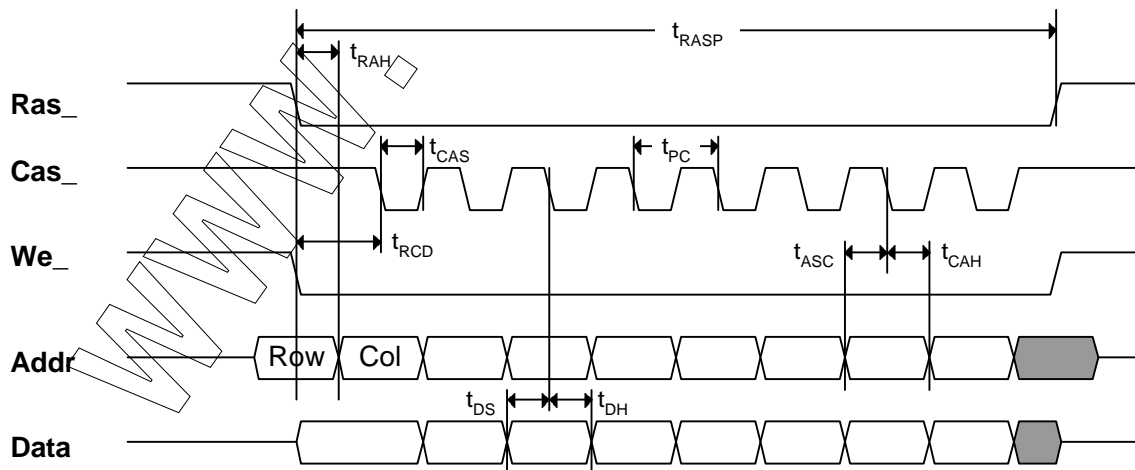

Figure 7. DRAM Interface Read Cycle Timing Waveform

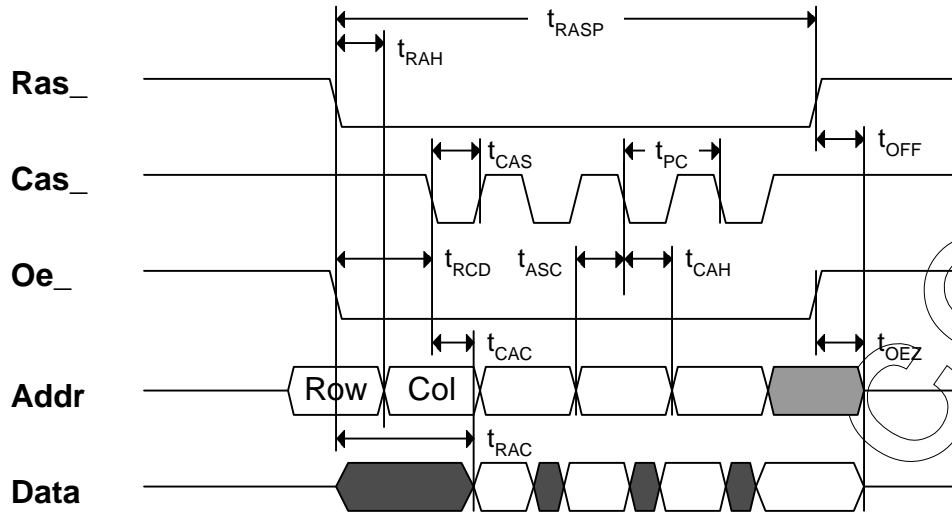

Figure 8. DRAM Interface Refresh Cycle Timing Waveforms

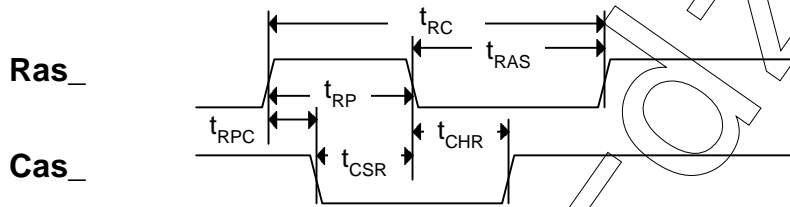

Table 3. Parameters of DRAM Interface Timing

Symbol	Parameter	Min	Max	Unit
t_{RASP}	RAS_ pulse width	185	—	ns
t_{RAH}	Row address hold time	18.5	—	ns
t_{CAS}	CAS_ pulse width	18.5	—	ns
t_{RCD}	RAS_ to CAS_ delay time	39	44	ns
t_{ASC}	Column address setup time	18.5	—	ns
t_{CAH}	Column address hold time	11.5	—	ns
t_{DS}	Data-in setup time	18.5	—	ns
t_{DH}	Data-in hold time	11.5	—	ns
t_{RAC}	Access time from RAS_	—	60	ns
t_{CAC}	Access time from CAS_	—	15	ns
t_{OEZ}	Output buffer turnoff delay from OE_	—	—	ns
t_{RPC}	RAS_ precharge to CAS_ hold time	18.5	—	ns
t_{CHR}	CAS_ hold time	55.5	—	ns
t_{CSR}	CAS_ setup time	55.5	—	ns
t_{RC}	Random read or write cycle time	185	—	ns
t_{RAS}	RAS_ pulse width	111	—	ns
t_{RP}	RAS_ precharge time	74	—	ns

2.2.3 OmniCE

OmniCE is a proprietary compression engine, constructed by the predictor, the quantizer, as well as encoder along with look-up tables. The predictor predicts image pixels horizontally and vertically. The look-up table can be programmed by the software driver according to calculation of probability.

The compression ratio of OmniCE varies from 4 to 8, depending on image complexity. Parameters can be modified dynamically by the software driver to achieve the desired frame rate. It can also be disabled and bypass uncompressed data.

Figure 9. Structure of OmniCE

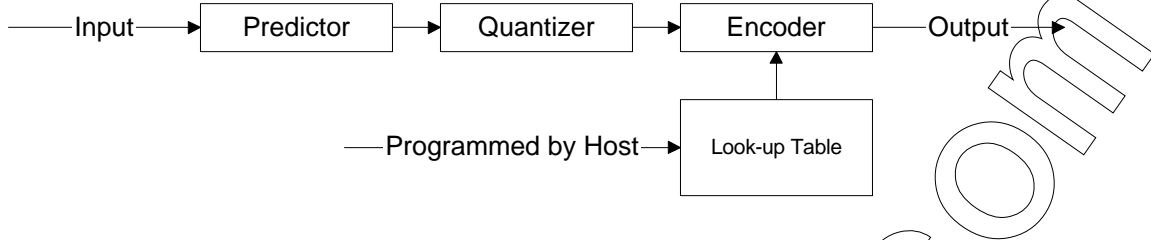

2.2.4 ISO FIFO

OV511+ implements one isochronous endpoint for video data transfer. The available alternates include packet size of 0, 33, 129, 257, 385, 513, 769 & 961. The corresponding ISO FIFO size has to be set by the software driver right before the current alternate is set. The size of ISO FIFO is configurable from 32 to 960 in increment of 32.

Moreover, in order to assist packet reordering in the host, a packet number inserted at the end of each packet can be turned on. An image frame starts with the SOF packet (Start Of an image Frame), while ends with the EOF packet (End Of an image Frame). The packet number counts up from 01 to 255 and back to 01. Only the SOF packet uses the packet number 00.

SOF/EOF packets are indicated by the unique combination which the 1st to the 8th byte are all "0"s and the 9th byte contains a non-zero header. This header contains image information, such as the operating mode, snapshot flag & even/odd field. In the case of the EOF packet, the 10th and 11th bytes also contain the image width and height information.

Figure 10. SOF/EOF Formats

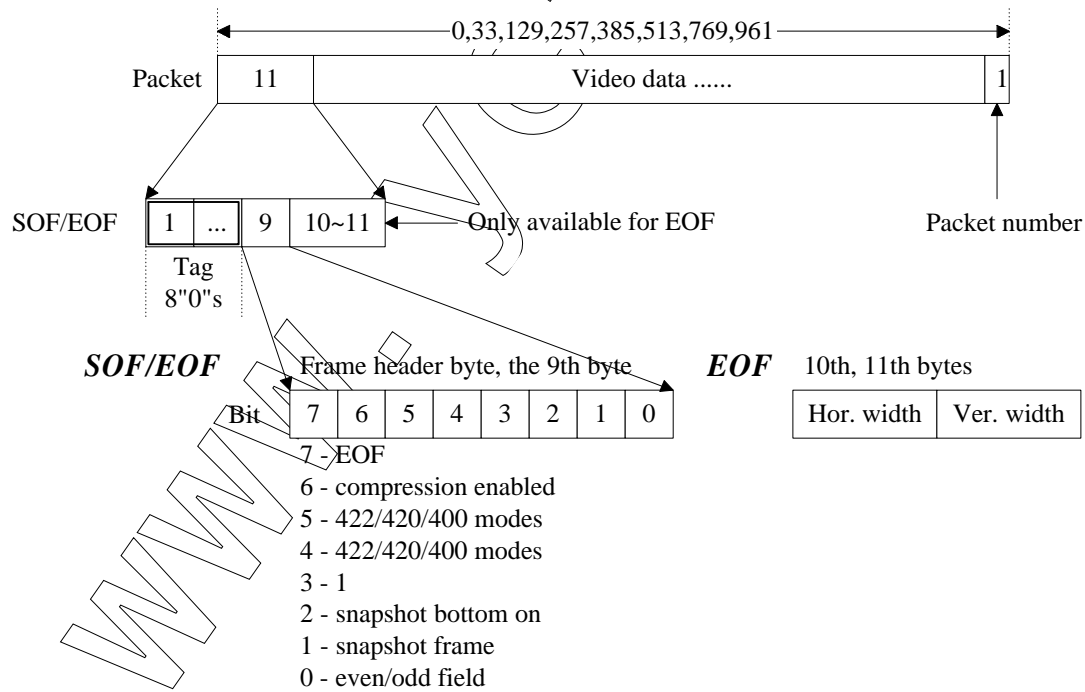

2.2.5 UDC interface

UDC interface performs hand-shaking protocols with USB Device Controller. Its function includes isochronous transfer, responding vendor commands & descriptors, and generating read/write cycles to internal registers.

2.2.6 System Control

System control unit performs functions of system clock generation, Power On Reset, software reset scheme, USB Reset command, system initialization, snapshot and USB suspend. OV511⁺ takes 48MHz crystal input for USB bus. "CLK_48M" is also divided by 2 and provides clock of core logic and camera clock. Pin "EN_OSC27" has to be pulled down.

Figure 11. Clock Scheme of OV511⁺

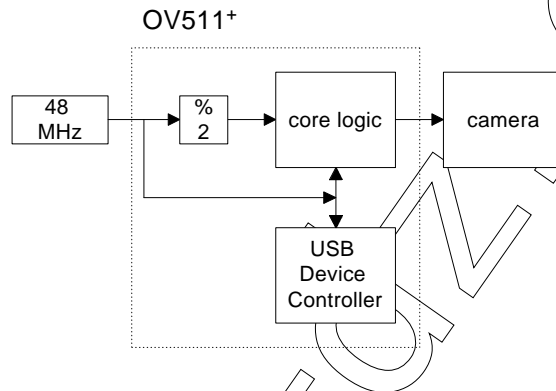

There are three kinds of reset scheme supported by OV511⁺. The Power-On Reset (pin "RESETB") and USB Reset command initialize OV511⁺ & camera circuits. The Camera Reset (pin "RESET") toggles as soon as either Power-On Reset or USB Reset is asserted. The software reset allows individual functional blocks to be reset without altering the register contents. Software reset is necessary when changing camera formats, ISO packet size, compression parameters, etc.

According to USB specification, a high-power (> 100mA) function requires staged switching of power. It must first come up in a reduced power state of less than one unit load, which is 100mA. System initialization function stops system clocks as well as sets camera into power down mode by using pin "PWDN" before bus enumeration. If sufficient power exists in the power budget, the remainder of the function will be powered on by setting register bit "EN_SYS" (register 53h). Pin "SPWDN" has to be pulled up for the current power management scheme.

The snapshot function can be achieved by either setting register bit "SNAP[2]" (register 52h) or pushing a button (pin "SNAPB") on the system. Hardware snapshot function is initiated by setting register bit "SNAP[0]" (register 52h). Once pushing the button, the internal snapshot signal is latched, registers of the camera interface & camera itself are automatically modified to desired formats as well. As soon as OV511⁺ captures one single frame of image and sends to the host, the software driver clears the internal snapshot signal for next snapshot operation by writing a sequence 0-1-0 to register bit "SNAP[1]" (register 52h).

When USB bus idles for more than 3 msec, OV511⁺ goes into suspend mode and all clocks are stopped by pin "OSC_EN", while all internal registers are remained the same values. The system wakes up when the USB resume condition occurs.

LED control pin "LEDCTL" is accessible by register bit "LEDCTL" (register 55h). It can also be a programmable I/O pin.

Switching power clock pin "PWCK" is programmable by register bit "PWCK[1:0]" (register 54h). It can be programmed to frequencies of 24K/48K/96K/192KHz.

2.2.7 USB Device Controller

The camera system constructed by OV511⁺ is defined as a “high-power, bus-powered” USB device. It means that the camera system draws over one and a maximum of five unit loads from the USB cable. Two endpoints are implemented for communication flows between the USB camera device and the USB host. Endpoint 0 is an In-Out type CONTROL endpoint which is the pipe of Descriptors, Configurations and Vendor Commands (internal registers). Endpoint 1 is an In type Isochronous endpoint which is the pipe of video streams.

Figure 12. USB Communication Flow

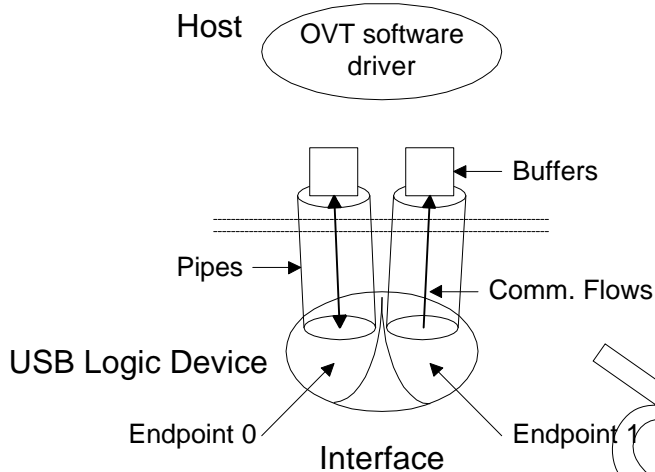

The USB Descriptors are configured as one configuration, one interface and eight alternates. The packet sizes of eight alternates are 0, 33, 129, 257, 385, 513, 769 & 961. Build-in USB transceiver (pull-down) and external transceiver interface (pull-up) can be switched by selecting pin “TXRSEL”. The camera system is defined as a full speed device and needs to be terminated with the pull-up resistor on the D+ line.

2.2.8 SCCB (Serial Camera Control Bus)

The data rate of the SCCB bus master is programmable and the maximum data rate is 100K.

2.2.9 PIO

PIO is a parallel I/O port for accessing external SRAM based devices. It has a standard memory like interface that requires address, data and read/write control signals. These signals share the same buses with the Y and UV video channels. When PIO is enabled, Y channel becomes the PIO data bus for both input and output modes, and UV channel becomes address bus and read/write control signals. In this case, video data inputs will be interrupted. The pin assignment of PIO control signals is as following,

- UV [5:0] share with ADDR [5:0], any arbitrary address can be defined by users as CSB
- UV [6] shares with WEB
- UV [7] shares with OEB

Figure 13. PIO Read Cycle Timing Waveforms

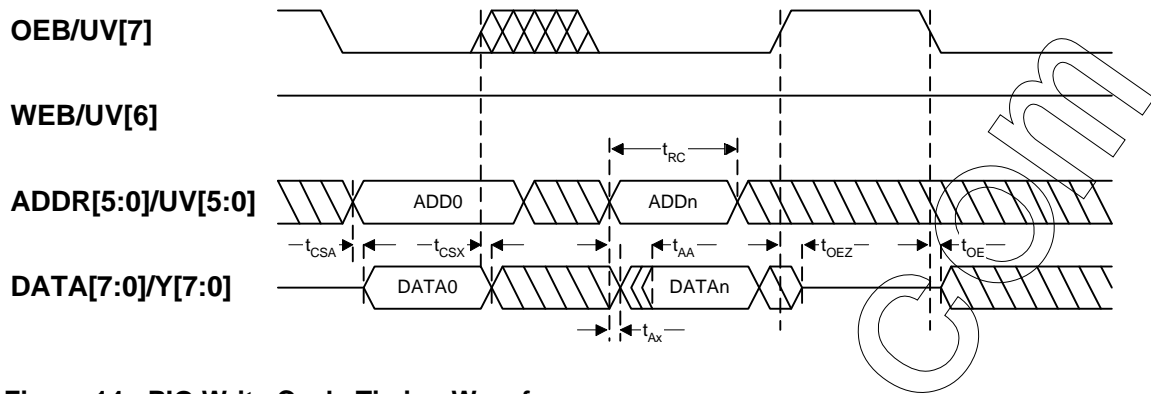

Figure 14. PIO Write Cycle Timing Waveforms

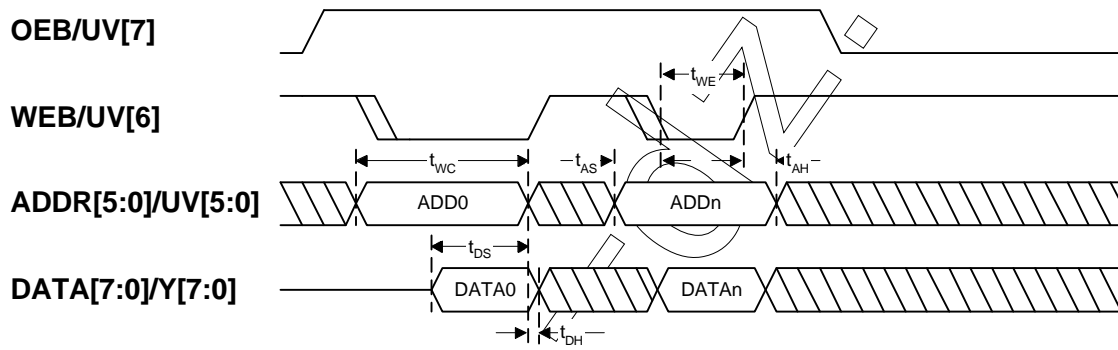

Table 4. Parameters of PIO Timing

Symbol	Parameter	Min	Max	Unit
T _{OE}	Output enable access time	15	—	ns
T _{OEZ}	Output enable to z delay	15	—	ns
T _{RC}	Register read cycle time	—	100	ns
T _{CSA}	Chip select access time	30	—	ns
T _{CSX}	Chip select to data invalid time	15	—	ns
T _{AA}	Address access time	30	—	ns
T _{AX}	Address data invalid time	15	—	ns
T _{WC}	Register write cycle time	—	100	ns
T _{WE}	Write enable pulse width	—	50	ns
T _{AS}	Write cycle address set up time	—	0	ns
T _{AH}	Write cycle address hold time	—	0	ns
T _{DS}	Write cycle data set up time	—	20	ns
T _{DH}	Write cycle data hold time	—	0	ns

2.2.10 Custom ID

Custom ID is a specific 8-bit input port that can be pulled up/down to identify company names of manufacturers. The Custom ID is checked by the software driver and may be requested directly from OVT. If no Custom ID is applied, pull-down resistors are also required to avoid bus floating. Pin "IDESL [1:0]" have to be set as "01".

3 Pin Definition

3.1 Pin Assignments

Figure 15. 100-Pin PQFP Package

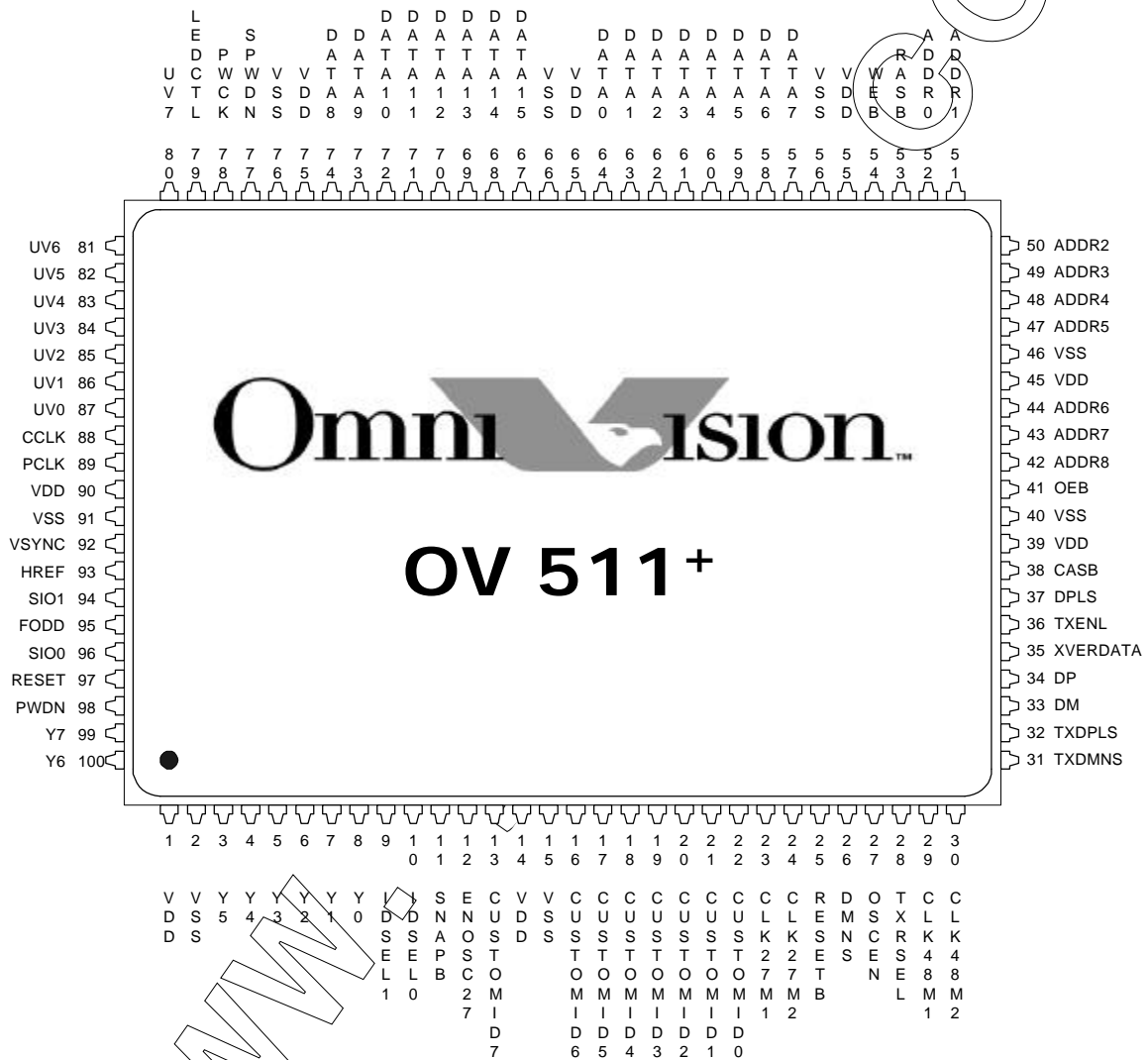

3.2 Pin Descriptions

Table 5. Pin Descriptions

Items/Pin #	Name	I/O	Function	mA
Camera Interface				
99, 100, 3-8	Y[7:0]	IT/OT	Camera Y data input PIO data input/output	8
80-87	UV[7:0]	IT/OT	Camera UV data input PIO address, read/write control output	8
89	PCLK	IT	Camera pixel clock input	
93	HREF	IT	Camera horizontal window reference input	
92	VSYNC	IT	Camera vertical sync. Input	
95	FODD	IT	Camera even/odd field flag input	
88	CCLK	O	Camera clock output. Software programmable	8
97	RESET	O	Camera hardware reset output	4
98	PWDN	O	Camera power switch control output	4
SCCB Interface				
96	SIO-0	IS/OD	SCCB serial data. Pull-up resistor (4.7K Ohm) is required Bi-directional	4
94	SIO-1	OD	SCCB serial clock output. Pull-up resistor (4.7K Ohm) is required	4
DRAM Interface				
67-74, 57-64	DATA[15:0]	IT/OT	DRAM 16-bit data	8
41	OEB	O	DRAM OE_ output	8
54	WEB	O	DRAM WE_ output	8
42-44, 47-52	ADDR[8:0]	O	DRAM address output	8
38	CASB	O	DRAM CAS_ output	8
53	RASB	O	DRAM RAS_ output	8
USB Interface				
35	XVER_DATA	IT	USB differential receiver data input (external transceiver)	
26	DMNS	IT	D- input (external transceiver)	
37	DPLS	IT	D+ input (external transceiver)	
36	TXENL	O	Output enable for differential driver (external transceiver)	4
31	TXDMNS	O	NRZI formatted D- output (external transceiver)	4
32	TXDPLS	O	NRZI formatted D+ output (external transceiver)	4
33	DM	UI/O	D- input/output (internal transceiver)	
34	DP	UI/O	D+ input/output (internal transceiver)	
Clock & Misc.				
25	RESETB	IS	Power-On Reset input. Low-active	
29	CLK_48M1	OSCI	48MHz oscillator/crystal input	
30	CLK_48M2	OSCO	48MHz crystal output	
23	CLK_27M1	OSCI	27MHz oscillator/crystal input	
24	CLK_27M2	OSCO	27MHz crystal output	
27	OSC_EN	O	Power control for oscillator. 1 for power enabled	4
28	TXRSEL	IS	Internal/external transceiver control. 0 for internal	
11	SNAPB	IS	Snapshot button input. Cleared by the software driver	
9-10	IDSEL[1:0]	IS	VID & PID select. 01 is required	
77	SPWDN	IS	Power down mode select. 1 is required	
13, 16-22	CUSTOM_ID[7:0]	IS	Custom ID inputs	

Pin Descriptions (continued)

Items/Pin #	Name	I/O	Function	mA
12	EN_OSC27	IS	27MHz clock input select. 1 for enabled	
78	PWCK	O	Switching power clock output	8
79	LEDCTL	O	LED control	4
Power & Ground				
1, 14, 39, 45, 55, 65	VDD	I	Power	
75, 90				
2, 15, 40, 46, 56, 66	VSS	I	Ground	
76, 91				

I : Input
 IS : CMOS Schmitt Trigger Level Input
 IT : TTL Level Input
 O : Normal Output
 OSCI : Oscillator Input
 OD : Open Drain Output
 OT : Tri-state Buffer Output
 OSCO : Oscillator Output
 UI/O : USB Transceiver Input / Output

4 Electrical Characteristics

Table 6. DC Electrical Characteristics

$V_{DD} = 5V \pm 5\%$, $T_A = 0$ to 70°C

Symbol	Parameter	Condition	Min	Max	Unit
V_{IH}	High level input voltage		3.5 (CMOS) ~ 2.0 (TTL)		V
V_{IL}	Low level input voltage			1.5 (CMOS) ~ 0.8 (TTL)	V
V_{T+}	Schmitt trigger, positive-going threshold			4.0 (CMOS)	V
V_{T-}	Schmitt trigger, negative-going threshold		1.0 (CMOS)		V
I_{IH}	High level input current	$V_{IN} = V_{DD}$	-10	10	μA
I_{IL}	Low level input current	$V_{IN} = V_{SS}$	-10	10	μA
V_{OH}	High level output voltage		2.4		V
V_{OL}	Low level output voltage			0.4	V
I_{OZ}	Tri-state output leakage current	$V_{OUT} = V_{SS}$ or V_{DD}	-10	10	μA
I_{DD}	Quiescent supply current	$V_{IN} = V_{SS}$ or V_{DD}		100	μA
C_{IN}	Input capacitance			4	pF
C_{OUT}	Output capacitance			4	pF

Table 7. Absolute Maximum Ratings

Symbol	Parameter	Rating	Unit
V_{DD}	DC supply voltage	-0.3 to 7	V
V_{IN}	DC input voltage	-0.3 to $V_{DD} + 0.3$	V
I_{IN}	DC input current	± 10	mA
T_{STG}	Storage temperature	-40 to 125	$^\circ\text{C}$

Table 8. Recommended Operating Conditions

Symbol	Parameter	Rating	Unit
V_{DD}	DC supply voltage 5V	4.75 to 5.25	V
T_A	Commercial temperature	0 to 70	$^\circ\text{C}$

Table 9. USB DC Electrical Characteristics

Symbol	Parameter	Condition	Min	Max	Unit
I_{CCS}	Suspended device			10	μA
I_{LO}	Hi-Z state data line leakage	$0V < V_{in} < 3.3V$	-10	10	μA
V_{DI}	Differential input sensitivity	$ (D+) - (D-) $	0.2		V
V_{CM}	Differential common mode range		0.8	2.5	V
V_{SE}	Single ended receiver threshold		0.8	2.0	V
V_{OL}	Static output low	R_L 1.5k Ω to 3.6V		0.2	V
V_{OH}	Static output high	R_L 1.5k Ω to GND	2.8	3.6	V
C_{IN}	Transceiver capacitance	Pin to GND		20	pF

Table 10. USB Full Speed Output Driver Electrical Characteristics

Symbol	Parameter	Condition	Min	Max	Unit
T_R	Rise time	$C_L = 50\text{pF}$	4	20	ns
T_F	Fall time	$C_L = 50\text{pF}$	4	20	ns
T_{rim}	Rise / Fall time matching	(T_r/T_f)	90	110	%
V_{Crs}	Output signal crossover Voltage		1.3	2.0	V
Z_{drv}	Driver output resistance	Steady state drive	28	43	Ω

5 Register Table (Vendor Commands)

5.1 CAMERA INTERFACE

Table 11. Camera Interface Register List

Register Address	Register Name	R/W	Function	Default Value
10h	DLYM[1:0]	RW	Bit 1~0 : Delay modes of video input signals 00 : no delay 01 : delays YUV by one PCLK 10 : delays HREF by one PCLK 11 : delays YUV and HREF by one PCLK	00h
11h	PEM[0]	RW	Bit 0 : Edge modes of PCLK 0 : PCLK negative edge latches video data 1 : PCLK positive edge latches video data	01h
12h	PXCNT[6:0]	RW	Bit 6~0 : Clamped pixel number It defines the clamped pixel number of a horizontal line in increment of 8 pixels. If the pixel number from camera is larger than this number, the spare pixels will be dropped. Clamped Pixel No. = $(PXCNT + 1) * 8$	27h
13h	LNCNT[6:0]	RW	Bit 6~0 : Clamped line number It defines the clamped line number in increment of 8 lines. If the line number from camera is larger than this number, the spare lines will be dropped. Clamped Line No. = $(LNCNT + 1) * 8$	1Dh
14h	PXDV[1:0]	RW	Bit 1~0 : Pixel divisor It defines down sampling frequency in the horizontal pixel direction. 00 : divided by 1 01 : divided by 2 10 : divided by 4 11 : divided by 8	01h
15h	LNDV[1:0]	RW	Bit 1~0 : Line divisor It defines down sampling frequency in the vertical line direction. Uses these register bits along with register bit LSTR to retain even or odd lines. 00 : divided by 1 01 : divided by 2 10 : divided by 4 11 : divided by 8	01h
16h	M400[0]	RW	Bit 0 : 8 bit (Y channel only) / 16 bit (Y & UV channels) data input select 0 : 8 bit data in Y channel (UV channel is ignored) 1 : 16 bit data in both Y & UV channels. Uses this register bit along with register bit M420 to select 422/420 formats.	01h
17h	LSTR[0]	RW	Bit 0 : Reserved lines for downing sampling 0 : even lines (2, 4, 6, 8,) 1 : odd lines (1, 3, 5, 7,)	00h
18h	M420[1] YFIR[0]	RW	Bit 1 : YUV422/420 0 : YUV 4:2:2 1 : YUV 4:2:0 Bit 0 : Y channel low pass filter 0 : disabled 1 : enabled	00h

- **Snapshot Operation** – a full set of camera interface registers are duplicated for hardware snapshot operation. These registers replace the normal ones for taking snapshot frame so that the snapshot frame can be different settings from normal frame. The followings are the snapshot registers.

Camera Interface Register List (continued)

Register Address	Register Name	R/W	Function	Default Value
19h	SPDLY[7:0]	RW	Bit 7~0 : Captured frame for snapshot It defines which frame (one frame only) after snapshot function is triggered will be captured. 00000000 : the first frame 10000001 ~ 11111111 : the 2 nd ~ 128 th frame	00h
1Ah	SNPX[6:0]	RW	Bit 6~0 : Clamped pixel number for snapshot	4Fh
1Bh	SNLN[6:0]	RW	Bit 6~0 : Clamped line number for snapshot	1Dh
1Ch	SNPD[1:0]	RW	Bit 1~0 : Pixel divisor for snapshot	00h
1Dh	SNLD[1:0]	RW	Bit 1~0 : Line divisor for snapshot	01h
1Eh	SN400[0]	RW	Bit 0 : 8/16 bit data input for snapshot	01h
1Fh	SNALSTR[2] SN420[1] SNYFIR[0]	RW	Bit 2 : Reserved lines for down sampling for snapshot Bit 1 : YUV422/420 for snapshot Bit 0 : Y channel low pass filter for snapshot	04h

5.2 DRAM INTERFACE

Table 12. DRAM Interface Register List

Register Address	Register Name	R/W	Function	Default Value
20h	ENFC[0]	RW	Bit 0 : Image flow control 0 : disabled, doesn't guarantee a complete image frame 1 : enabled, guarantees a complete image frame	01h
21h	ARCP[0]	RW	Bit 0 : Auto read cycle predictor It predicts the number of read cycles that will be inserted besides write cycles. 0 : disabled, use register bit MRC for manual setting 1 : enabled	01h
22h	MRC[3:0]	RW	Bit 3~0 : Manual read cycle insertion It defines the number of read cycles that will be inserted besides write cycles. Read cycles = MRC + 1	01h
23h	RFC[5:0]	RW	Bit 5~0 : Refresh counter	1Ah

5.3 ISO FIFO

Table 13. ISO FIFO Register List

Register Address	Register Name	R/W	Function	Default Value
30h	PKSZ[4:0]	RW	Bit 4~0 : Packet size It defines the packet size of ISO FIFO which is available from 00000 (0 bytes) to 11110 (960 bytes). The packet size must match with the current alternate setting. Packet size = (32 * PKSZ) bytes	08h
31h	NZPK[3] ENPKNO[1] ENCE[0]	RW	Bit 3 : Zero packet inserted after EOF (image end of frame flag) 0 : disabled 1 : enabled Bit 1 : Packet No. insertion It inserts one extra byte at the end of each packet as the packet number. It counts in sequence, but only the packet containing SOF (image start of frame flag) uses "00". 0 : disabled 1 : enabled Bit 0 : Compressed data non-zero (01) insertion It inserts "01" at the 7 th byte of the packet if the 1 st ~8 th incoming compressed data are all "00". 0 : enabled 1 : disabled	03h

5.4 PIO

Table 14. PIO Register List

Register Address	Register Name	R/W	Function	Default Value
38h	ENPIO[7] PIORW[6] PADD[5:0]	W	Bit 7 : Parallel IO operation 0 : disabled 1 : enabled. UV channel changes to output mode for parallel IO operation. Register bits PADD[5:0] output to pin UV[5:0]. UV[6] performs as OEB, while UV[7] performs as WEB. Y channel is bi-directional. The direction depends on read/write operation of PIO. The bus cycle is executed once only after USB host write to this register and ENPIO = 1. Write data has to be placed in register bits PDATA[7:0] before launching the PIO write cycle. Read data is returned in register bits PDATA[7:0] after launching the PIO read cycle. Bit 6 : Read/write cycle for PIO operation 0 : read cycle 1 : write cycle Bit 5-0 : address port of PIO operation	00h
39h	PDATA[7:0]	RW	Bit 7-0 : data port of PIO operation	00h
3Eh	ENTP[3] TPS[2:0]	W	Bit 3 : BIST operation for OV511+ 0 : disabled 1 : enabled Bit 2-0 : BIST functions select	00h

- **PIO R/W sequence examples**

Write cycles

1. Writes to data port (PDATA, register 39h)
2. Enables PIO (ENPIO, register 38h), sets up address (PADD, register 38h), & selects write cycle (PIORW, register 38h)
3. Disables PIO (ENPIO, register 38h)

Read cycles

1. Enables PIO (ENPIO, register 38h), sets up address (PADD, register 38h), & selects read cycle (PIORW, register 38h)
2. Reads from data port (PDATA, register 39h)

5.5 SCCB

Table 15. SCCB Register List

Register Address	Register Name	R/W	Function	Default Value
40h	TMOU[2] NOACK[1] IDLE[0]	R	Bit 2 : Time out flag for SCCB operation. Sets when timer reaches the value set by register bits TMO[4:0]. Bit 1 : No acknowledge on SCCB bus. It's valid when register bit IDLE is set. Bit 0 : SCCB bus idle flag	00h
40h	ENABORT[4] TYPE[2:1] STARTSCCB[0]	W	Bit 4 : Aborts SCCB bus cycle if SCCB slave doesn't response (no acknowledge) Bit 2-1 : Types of SCCB read/write sequence 00 : 3 byte write cycle, in sequence of slave ID (SID), sub address (SWA) & SCCB data (SIO-0) 01 : 2 byte write cycle, in sequence of slave ID (SID) & sub address (SMA) 1x : 2 byte read cycle, in sequence of slave ID (SRA) & SCCB data (SIO-0) Bit 0 : Launches a new SCCB bus cycle if set SCCB won't launch a new cycle if it doesn't finish the previous bus cycle.	00h

SCCB Register List (continued)

Register Address	Register Name	R/W	Function	Default Value
41h	SID[7:0]	RW	Bit 7~0 : SCCB slave ID for 3 or 2 byte write cycles	00h
42h	SWA[7:0]	RW	Bit 7~0 : Sub address for 3 byte write cycles	00h
43h	SMA[7:0]	RW	Bit 7~0 : Sub address for 2 byte write cycles	00h
44h	SRA[7:0]	RW	Bit 7~0 : Slave ID for 2 byte read cycles	00h
45h	SIO-0[7:0]	RW	Bit 7~0 : SCCB read/write data port	00h
46h	PSC[7:0]	RW	Bit 7~0 : SCCB clock prescaler It defines prescaler values for SCCB clock. SCCB bit rate = 93.5 KHz / (PSC + 1)	06h
47h	TMO[4:0]	RW	Bit 4~0 : Time out counter A timer starts to count SCCB clocks when SCCB bus cycle is launched. When the timer reaches TMO, TMOUT is set.	00h

- Snapshot Operation** - During the period of hardware snapshot operation, OV511⁺ first launches a 3 byte SCCB write cycle to SCCB slave device, such as camera, by using register 48h and 49h. It permits SCCB slave device to modify the internal settings before taking the snapshot.

SCCB Register List (continued)

Register Address	Register Name	R/W	Function	Default Value
48h	SPA[7:0]	W	Bit 7~0 : Sub address of the SCCB write cycle for snapshot operation	00h
49h	SPD[7:0]	W	Bit 7~0 : Data port of the SCCB write cycle for snapshot operation	00h

- SCCB R / W Sequence Examples**

Setup stage

- Writes to slave ID (SID, register 41h)

3 byte write cycles

- Writes to sub address (SWA, register 42h)
- Writes to data port (SIO-0, register 45h)
- Writes to control bits to select write cycle and launch SCCB cycles (TYPE, STARTSCCB, register 40h)

2 byte dummy write cycles (In order to set sub address of SCCB slave device for the next coming read cycle)

- Writes to sub address (SMA, register 43h)
- Writes to control bits to select write cycle and launch SCCB cycles (TYPE, STARTSCCB, register 40h)

2 byte read cycles

- Writes to sub address (SRA, register 44h)
- Writes to control bits to select read cycle and launch SCCB cycles (TYPE, STARTSCCB, register 40h)
- Reads from status bits (TMOUT, NOACK, IDLE, register 40h)
- Reads from data port (SIO-0, register 45h)

5.6 SYSTEM CONTROL

Table 16. System Control Register List

Register Address	Register Name	R/W	Function	Default Value
50h	RST[6:0]	RW	Bit 0 : Software reset for Flush Bit 1 : Software reset for SCCB Bit 2 : Software reset for ISO FIFO Bit 3 : Software reset for OmniCE Bit 4 : Software reset for DRAM interface Bit 5 : Software reset for camera interface Bit 6 : Software reset for OV511 ⁺ & registers	00h
51h	CLKDIV[4:0]	RW	Bit 4-0 : Camera clock divisor It defines the frequency of camera clock output CCLK. CCLK is divided down based on external clock inputs CLK_48 or CLK_27. The maximum frequency of CLK_27 that OV511 ⁺ can handle is 27MHz. If both CLK_27 and CLK_48 clock inputs are enabled by pulling up pin "EN_OSC27", CLK_27 is chosen in support of camera clock. 00000 : no division (CLK_27) 11111 : CLK_27 divided by 32 If only CLK_48 clock input is enabled by pulling down pin "EN_OSC27", CLK_48 is divided by 2 and provides camera clock.	00h
52h	SNAP[3:0]	RW	Bit 0 : Hardware snapshot 0 : disabled 1 : enabled Bit 1 : Releases hardware snapshot bottom in sequence of 0,1,0 Bit 2 : Software snapshot 0 : disabled 1 : enabled Bit 3 : Snapshot status (read only)	01h
53h	EN_SYS[0]	W	Bit 0 : Software system initialization Before system is initialized, system clocks will be stopped to meet the requirement of power consumption for the whole system to be less than 100mA. After that, it can increase to max. 500mA for USB bus powered device. If pin "EN_SYSTEM" is pulled down, this bit controls system initialization. Otherwise, system is initialized right after power-on reset. 0 : system is not initialized 1 : system is initialized	00h
54h	PWCK[1:0]	RW	Bit 1-0 : Switching power clock output select 00 : 24KHz 01 : 48KHz 10 : 96KHz 11 : 192KHz	02h
55h	LEDCTL	RW	Bit 0 : LED control	00h
5Eh	USR[7:0]	RW	Bit 7-0 : User defined read/write register bits	00h
5Fh	CID[7:0]	R	Bit 7-0 : Custom ID which links to input pins "CUSTOM_ID" It is checked by the software driver to identify company names. It may be requested directly from OVT. The registered custom ID can be coded by pulling up or down resistors through pins "CUSTOM ID". If no custom ID is applied, pull-up/down resistors are also requested to avoid floating.	~

5.7 OmniCE

Table 17. OmniCE Register List

Register Address	Register Name	R/W	Function	Default Value
70h	PRH_Y[5:0]	RW	Bit 5~0 : Predication range in horizontal direction for Y channel One horizontal line is divided into horizontal segments for prediction. It defines the number of pixels contained in one horizontal segment of Y channel. Pixels in the segment except the first one are predicted by the first pixel of this segment.	1Fh
71h	PRH_UV[5:0]	RW	Bit 5~0 : Predication range in horizontal direction for UV channel	05h
72h	PRV_Y[7:0]	RW	Bit 7~0 : Predication range in vertical direction for Y channel One image frame is divided into vertical segments for prediction. It defines the number of pixels contained in one vertical segment of Y channel. Pixels in the segment except the first one are predicted by the first pixel of this segment.	06h
73h	PRV_UV[7:0]	RW	Bit 7~0 : Predication range in vertical direction for UV channel	06h
74h	QTH_Y[7:0]	RW	Bit 7~0 : Quantization threshold in horizontal direction for Y channel	14h
75h	QTH_UV[7:0]	RW	Bit 7~0 : Quantization threshold in horizontal direction for UV channel	03h
76h	QTV_Y[7:0]	RW	Bit 7~0 : Quantization threshold in vertical direction for Y channel	04h
77h	QTV_UV[7:0]	RW	Bit 7~0 : Quantization threshold in vertical direction for UV channel	04h
78h	UV_en[2] Y_en[1] CE_en[0]	RW	Bit 0 : OmniCE 0 : disabled 1 : enabled Bit 1 : Y channel operation 0 : disabled 1 : enabled Bit 2 : UV channel operation 0 : disabled 1 : enabled	06h
79h	LTEN_UV[1] LTEN_Y[0]	RW	Bit 0 : Look-up table for Y channel 0 : disabled 1 : enabled Bit 1 : Look-up table for UV channel 0 : disabled 1 : enabled	00h
80~9Fh	LT_Y	RW	Bit 7~0 : Programmable look-up table for Y channel	~
A0~BFh	LT_UV	RW	Bit 7~0 : Programmable look-up table for UV channel	~

6 USB Descriptors

The USB descriptor is a data structure with defined attributes that can respond requests from the USB host. The descriptors of OV511⁺ are hardware coded inside the chip, and no external EPROM is required.

6.1 Device

The device descriptor describes general information about OV511⁺. There is one device descriptor.

Table 18. Device Descriptor List

Offset	Field	Size	Value (Hex)	Description
0	Blength	1	12	Size of descriptor in bytes
1	BdescriptorType	1	01	DEVICE Descriptor Type
2	BcdUSB	2	0100	USB Spec Release No.
4	BdeviceClass	1	00	Class code
5	BdeviceSubClass	1	00	Subclass code
6	BdeviceProtocol	1	00	Protocol code
7	BmaxPacketSize0	1	08	Max. packet size for enpt0
8	IdVendor	2	05a9	Vendor ID
10	IdProduct	2	A511	Product ID
12	BcdDevice	2	0100	Device release No.
14	Imanufacturer	1	00	Index of string descriptor describing manufacturer
15	lproduct	1	00	Index of string descriptor describing product
16	IserialNumber	1	00	Index of string descriptor describing the device's serial no.
17	BnumConfigurations	1	01	Number of possible configurations

6.2 Configuration

The configuration descriptor describes information about a specific device configuration. There is one configuration descriptor.

Table 19. Configuration Descriptor List

Offset	Field	Size	Value (Hex)	Description
0	Blength	1	09	Size of descriptor in bytes
1	BdescriptorType	1	02	CONFIGURATION
2	WtotalLength	2	0089	Total length of data returned for this configuration
4	BnumInterfaces	1	01	No. of interfaces supported by this config.
5	BconfigurationValue	1	01	Value to use to Set Config. to select this config.
6	Iconfiguration	1	00	Index of string descriptor describing this config.
7	BmAttributes	1	80	Config. char. bus powered, no remote wakeup
8	MaxPower	1	FA	Max. power consumption, 500 ma

6.3 Interface & Endpoint

The interface descriptor describes a specific interface provided by the associated configuration. There are eight interface descriptors. Each one selects one alternate setting and is followed by the corresponding endpoint descriptor.

The endpoint descriptor describes the information required by the host to determine the bandwidth requirements of each endpoint. There is no endpoint descriptor for endpoint zero.

6.3.1 Alternate 0

Table 20. Interface Descriptor List of Alternate 0

Offset	Field	Size	Value (Hex)	Description
0	Blength	1	09	Size of descriptor in bytes
1	BdescriptorType	1	04	INTERFACE
2	BinterfaceNumber	1	00	No. of interface
3	BalternateSetting	1	00	Value used to select alternate setting
4	BnumEndpoints	1	01	No. of endpoints used by this interface
5	BinterfaceClass	1	FF	Class code
6	BinterfaceSubClass	1	00	SubClass code
7	BinterfaceProtocol	1	00	Protocol code
8	Interface	1	00	Index of string descriptor describing this interface

Table 21. Endpoint Descriptor List of Alternate 0, Packet Size 0

Offset	Field	Size	Value (Hex)	Description
0	Blength	1	07	Size of descriptor in bytes
1	BdescriptorType	1	05	ENDPOINT
2	BendpointAddress	1	81	Bit7 1 In Enpt, Bit 6..4 000, Bit 3..0 0001 Enpt No.
3	BmAttributes	1	01	Bit1..0 01 Iso
4	WmaxPacketSize	2	0000	Max. packet size 0
6	Binterval	1	01	Interval for polling enpt for data transfer

6.3.2 Alternate 1

Table 22. Interface Descriptor List of Alternate 1

Offset	Field	Size	Value (Hex)	Description
0	Blength	1	09	Size of descriptor in bytes
1	BdescriptorType	1	04	INTERFACE
2	BinterfaceNumber	1	00	No. of interface
3	BalternateSetting	1	01	Value used to select alternate setting
4	BnumEndpoints	1	01	No. of endpoints used by this interface
5	BinterfaceClass	1	FF	Class code
6	BinterfaceSubClass	1	00	SubClass code
7	BinterfaceProtocol	1	00	Protocol code
8	Interface	1	00	Index of string descriptor describing this interface

Table 23. Endpoint Descriptor List of Alternate 1, Packet Size 33

Offset	Field	Size	Value (Hex)	Description
0	Blength	1	07	Size of descriptor in bytes
1	BdescriptorType	1	05	ENDPOINT
2	BendpointAddress	1	81	Bit7 1 In Enpt, Bit 6..4 000, Bit 3..0 0001 Enpt No.
3	BmAttributes	1	01	Bit1..0 01 Iso
4	WmaxPacketSize	2	0021	Max. packet size 33
6	Binterval	1	01	Interval for polling enpt for data transfer

6.3.3 Alternate 2

Table 24. Interface Descriptor List of Alternate 2

Offset	Field	Size	Value (Hex)	Description
0	Blength	1	09	Size of descriptor in bytes
1	BdescriptorType	1	04	INTERFACE
2	BinterfaceNumber	1	00	No. of interface
3	BalternateSetting	1	02	Value used to select alternate setting
4	BnumEndpoints	1	01	No. of endpoints used by this interface
5	BinterfaceClass	1	FF	Class code

Interface Descriptor List of Alternate 2 (continued)

6	BinterfaceSubClass	1	00	SubClass code
7	BinterfaceProtocol	1	00	Protocol code
8	linterface	1	00	Index of string descriptor describing this interface

Table 25. Endpoint Descriptor List of Alternate 2, Packet Size 129

Offset	Field	Size	Value (Hex)	Description
0	Blength	1	07	Size of descriptor in bytes
1	BdescriptorType	1	05	ENDPOINT
2	BendpointAddress	1	81	Bit7 1 In Enpt, Bit 6..4 000, Bit 3..0 0001 Enpt No.
3	BmAttributes	1	01	Bit1..0 01 Iso
4	WmaxPacketSize	2	0081	Max. packet size 129
6	Binterval	1	01	Interval for polling enpt for data transfer

6.3.4 Alternate 3

Table 26. Interface Descriptor List of Alternate 3

Offset	Field	Size	Value (Hex)	Description
0	Blength	1	09	Size of descriptor in bytes
1	BdescriptorType	1	04	INTERFACE
2	BinterfaceNumber	1	00	No. of interface
3	BalternateSetting	1	03	Value used to select alternate setting
4	BnumEndpoints	1	01	No. of endpoints used by this interface
5	BinterfaceClass	1	FF	Class code
6	BinterfaceSubClass	1	00	SubClass code
7	BinterfaceProtocol	1	00	Protocol code
8	linterface	1	00	Index of string descriptor describing this interface

Table 27. Endpoint Descriptor List of Alternate 3, Packet Size 257

Offset	Field	Size	Value (Hex)	Description
0	Blength	1	07	Size of descriptor in bytes
1	BdescriptorType	1	05	ENDPOINT
2	BendpointAddress	1	81	Bit7 1 In Enpt, Bit 6..4 000, Bit 3..0 0001 Enpt No.
3	BmAttributes	1	01	Bit1..0 01 Iso
4	WmaxPacketSize	2	0101	Max. packet size 257
6	Binterval	1	01	Interval for polling enpt for data transfer

6.3.5 Alternate 4

Table 28. Interface Descriptor List of Alternate 4

Offset	Field	Size	Value (Hex)	Description
0	Blength	1	09	Size of descriptor in bytes
1	BdescriptorType	1	04	INTERFACE
2	BinterfaceNumber	1	00	No. of interface
3	BalternateSetting	1	04	Value used to select alternate setting
4	BnumEndpoints	1	01	No. of endpoints used by this interface
5	BinterfaceClass	1	FF	Class code
6	BinterfaceSubClass	1	00	SubClass code
7	BinterfaceProtocol	1	00	Protocol code
8	linterface	1	00	Index of string descriptor describing this interface

Table 29. Endpoint Descriptor List of Alternate 4, Packet Size 385

Offset	Field	Size	Value (Hex)	Description
0	Blength	1	07	Size of descriptor in bytes
1	BdescriptorType	1	05	ENDPOINT
2	BendpointAddress	1	81	Bit7 1 In Enpt, Bit 6..4 000, Bit 3..0 0001 Enpt No.
3	BmAttributes	1	01	Bit1..0 01 Iso

Endpoint Descriptor List of Alternate 4, Packet Size 385 (continued)

4	WmaxPacketSize	2	0181	Max. packet size 385
6	Binterval	1	01	Interval for polling enpt for data transfer

6.3.6 Alternate 5

Table 30. Interface Descriptor List of Alternate 5

Offset	Field	Size	Value (Hex)	Description
0	Blength	1	09	Size of descriptor in bytes
1	BdescriptorType	1	04	INTERFACE
2	BinterfaceNumber	1	00	No. of interface
3	BalternateSetting	1	05	Value used to select alternate setting
4	BnumEndpoints	1	01	No. of endpoints used by this interface
5	BinterfaceClass	1	FF	Class code
6	BinterfaceSubClass	1	00	SubClass code
7	BinterfaceProtocol	1	00	Protocol code
8	linterface	1	00	Index of string descriptor describing this interface

Table 31. Endpoint Descriptor List of Alternate 5, Packet Size 513

Offset	Field	Size	Value (Hex)	Description
0	Blength	1	07	Size of descriptor in bytes
1	BdescriptorType	1	05	ENDPOINT
2	BendpointAddress	1	81	Bit7 1 In Enpt, Bit 6..4 000, Bit 3..0 0001 Enpt No.
3	BmAttributes	1	01	Bit1..0 01 Iso
4	WmaxPacketSize	2	0201	Max. packet size 513
6	Binterval	1	01	Interval for polling enpt for data transfer

6.3.7 Alternate 6

Table 32. Interface Descriptor List of Alternate 6

Offset	Field	Size	Value (Hex)	Description
0	Blength	1	09	Size of descriptor in bytes
1	BdescriptorType	1	04	INTERFACE
2	BinterfaceNumber	1	00	No. of interface
3	BalternateSetting	1	06	Value used to select alternate setting
4	BnumEndpoints	1	01	No. of endpoints used by this interface
5	BinterfaceClass	1	FF	Class code
6	BinterfaceSubClass	1	00	SubClass code
7	BinterfaceProtocol	1	00	Protocol code
8	linterface	1	00	Index of string descriptor describing this interface

Table 33. Endpoint Descriptor List of Alternate 6, Packet Size 769

Offset	Field	Size	Value (Hex)	Description
0	Blength	1	07	Size of descriptor in bytes
1	BdescriptorType	1	05	ENDPOINT
2	BendpointAddress	1	81	Bit7 1 In Enpt, Bit 6..4 000, Bit 3..0 0001 Enpt No.
3	BmAttributes	1	01	Bit1..0 01 Iso
4	WmaxPacketSize	2	0301	Max. packet size 769
6	Binterval	1	01	Interval for polling enpt for data transfer

6.3.8 Alternate 7

Table 34. Interface Descriptor List of Alternate 7

Offset	Field	Size	Value (Hex)	Description
0	Blength	1	09	Size of descriptor in bytes
1	BdescriptorType	1	04	INTERFACE

Interface Descriptor List of Alternate 7 (continued)

2	BinterfaceNumber	1	00	No. of interface
3	BalternateSetting	1	07	Value used to select alternate setting
4	BnumEndpoints	1	01	No. of endpoints used by this interface
5	BinterfaceClass	1	FF	Class code
6	BinterfaceSubClass	1	00	SubClass code
7	BinterfaceProtocol	1	00	Protocol code
8	linterface	1	00	Index of string descriptor describing this interface

Table 35. Endpoint Descriptor List of Alternate 7, Packet Size 961

Offset	Field	Size	Value (Hex)	Description
0	Blength	1	07	Size of descriptor in bytes
1	BdescriptorType	1	05	ENDPOINT
2	BendpointAddress	1	81	Bit7 1 In Enpt, Bit 6..4 000, Bit 3..0 0001 Enpt No.
3	BmAttributes	1	01	Bit1..0 01 Iso
4	WmaxPacketSize	2	03C1	Max. packet size 961
6	Binterval	1	01	Interval for polling enpt for data transfer

www.yc-dz.com

7 Software Package

The followings are software drivers that are or will be supported by OVT.

- **Stream Class MiniDriver** - A WDM (Microsoft Win32 Driver Model) stream class driver that supports the OVT USB camera system in the Microsoft Windows 98 and Windows 2000. This driver is the bottom level of the software system, and it completes all actual control actions.
- **Video for Windows Compatible Driver** - The VFW is the standard interface of Microsoft for Video Capture drivers. Package contains a VFW-to-WDM mapper extension DLL. It adds some pages in Video source property control dialog. This driver allows user control every custom property.
- **TWAIN Source Control Driver** - This driver is compatible with Microsoft still image architecture in Windows 98. It allows standard still image oriented application which use the TWAIN API to use the OVT USB Camera system.
- **DirectShow Filter** - This software component allows users to control every custom property in DirectShow graph.
- **Installation Software** - The installation software is responsible for setting up all camera software components.

8 Mechanical Information

Dimensions in Millimeters

