

Agilent ADCS-1121, ADCS-2121 CMOS Monochrome Image Sensors Data Sheet

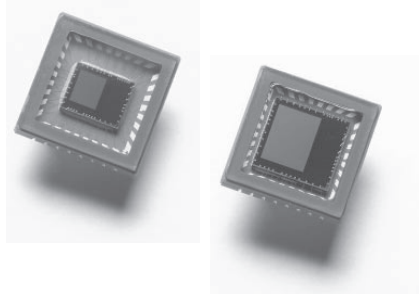
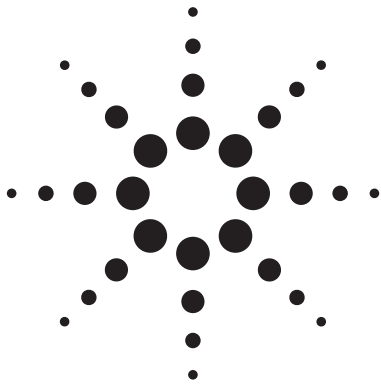

Description

The ADCS-1121 and ADCS-2121 CMOS Monochrome Image Sensors capture high quality, low noise images while consuming very low power. These parts integrate a highly sensitive active pixel photodiode array with timing control and onboard A/D conversion. Available in either VGA (640x480) or CIF (352x288) resolution image arrays, the devices are ideally suited for a wide variety of applications.

The ADCS-2121 and ADCS-1121, when coupled with compatible image processors from either Agilent or selected Agilent partners, provide a complete imaging system to enable rapid end-product development. Designed for low-cost consumer electronic applications, the ADCS-2121 and ADCS-1121 sensors deliver unparalleled performance for mainstream imaging applications.

ADCS-2121 (VGA) and ADCS-1121 (CIF) are CMOS active pixel image sensors with integrated A/D conversion and full timing control. They provide random access of sensor pixels, which allows windowing and

panning capabilities. The sensor is designed for video applications and still image capabilities. The ADCS family achieves excellent image quality with very low dark current, high sensitivity, and superior anti-blooming characteristics. The devices operate from a single DC bias voltage, are easy to configure and control, and feature low power consumption.

Programmable Features

- Programmable window size ranging from the full array down to a 4 x 4 pixel window
- Programmable panning capability which allows a specified window (minimum 4x4 pixels) to be located anywhere on the sensor array
- Internal register set programmable via either the UART or Synchronous serial interface
- Integrated timing controller with rolling electronic shutter, row/column addressing, and operating mode selection with programmable exposure control, frame rate, and data rate
- Programmable horizontal, vertical, and shutter synchronization signals
- Programmable horizontal and vertical blanking intervals

Key Specifications and Features

- High quality, low cost CMOS image sensors
- Industry-standard 32-pin CLCC package
- VGA resolution (640H x 480V) – ADCS-2121
- CIF resolution (352H x 288V) – ADCS-1121
- High frame rates for digital video
VGA: 15 frames/second
CIF: 30 frames/second
- High sensitivity, low noise design ideal for capturing high-quality images in a variety of lighting conditions
- Integrated analog-to-digital converters:
VGA (ADCS-2121): 10 bit, programmable
CIF (ADCS-1121): 8 bit, fixed
- Parallel and serial output
- Automated, dark response compensation
- Automatic subtraction of column fixed pattern noise
- Still image capability
- Synchronous serial or UART interface
- Integrated voltage references

Applications

- Bar code scanners
- Biometrics
- Machine vision
- Optical character recognition
- Surveillance



Brief Introduction

The Agilent ADCS-2121 and Agilent ADCS-1121 image sensors act as normal CMOS digital devices from the outside. Internal circuits are a combination of sensitive analog and timing circuits. Therefore, the designer must pay attention to the PC board layout and power supply design. Writing to registers via an I²C compatible two-wire interface provides control of the sensor. Sensor data is normally output via an 8 or 10 bit parallel interface (serial data output is also available). Once the registers are programmed the sensor is self-clocking and all timing is internally generated. Analog to digital conversion is also on chip and 8 or 10 bit digital data is output. A data ready pulse follows each valid pixel output. An end of row signal follows each row and an end of frame signal follows each frame.

PCB Layout

Analog V_{dd} and analog ground need to be routed separately from digital V_{dd} and digital ground. Noisy circuits or ICs should not be placed on the opposite side of the PC board. Heat producing circuits such as microprocessors or LCD displays should not be placed next to or opposite from the sensor to reduce noise in the image.

Power Supply

The sensor operates at 3.3 VDC. There are two power supplies for the sensor. Analog V_{dd} and Digital V_{dd}. The two supplies and grounds must be kept separate. Two separate regulators provide the best isolation. Any noise on the analog supply will result in noise in the image. Analog and digital ground should be tied together at a single point of lowest impedance and noise.

Master Clock

The part requires a 50% duty cycle master clock. Maximum clock rates are 25 MHz for ADCS-2121 and 32 MHz for ADCS-1121.

Reset

A hard reset is required before the sensor will function properly. Once the master clock is running, assert nRST_nSTBY for 40 clock cycles.

Register Communication

Communication (read/write) to the sensor registers is via a two wire serial interface—either a synchronous I²C compatible or half duplex UART (9600 baud default). nTristate (pin 3 ADCS-1121 only) must be pulled high for normal operation. The ADCS-2121 does not have nTristate.

Parallel Data Output

8 or 10 bit parallel data is output from the sensor. A data ready line (DRDY) is asserted when the data is valid. The sensor acts as a master in the way it outputs data. There is no flow control or data received handshake. Once the RUN bit (CONTROL register) is set, the image processor must be ready to accept data at the sensor rate and when the data is presented.

Serial Data Output

In this mode, output data lines D0 and D1 (the lower two bits of the parallel data port) act as a two wire serial interface.

Handshaking

At the end of one row of data, the nROW line is asserted. At the end of one frame of data, the nFRAME_nSYNC line is asserted.

Registers

On the next page is a table of sample register settings (see Figure 1). These values are a good starting point.

Table 1. Register Set Declaration for Agilent ADCS-1121 and ADCS-2121 Image Sensors.

Register Name	Mnemonic	Address (hex)	Sample Value (hex)
Identifications Register	IDENT	0x00	
Status Register	STATUS	0x01	0x7F
Interrupt Mask Register	IMASK	0x02	0x00
Pad Control Register	PCTRL	0x03	0x03
Pad Drive Control Register	PDRV	0x04	0x00
Interface Control Register	ICTRL	0x05	0x20
Interface Timing Register	ITMG	0x06	0x00
Baud Fraction Register	BFRAC	0x07	0x00
Baud Rate Register	BRATE	0x08	0x00
ADC Control Register	ADCCTRL	0x09	0x08
First Window Row Register	FWROW	0x0A	0x00
First Window Column Register	FWCOL	0x0B	0x07
Last Window Row Register	LWROW	0x0C	0x79
Last Window Column Register	LWCOL	0x0D	0xA8
Timing Control Register	TCTRL	0x0E	0x04
Row Exposure Low Register	ROWEXPL	0x13	0x00
Row Exposure High Register	ROWEXPH	0x14	0x02
Sub-Row Exposure Register	SROWEXP	0x15	0x00
Error Control Register	ERROR	0x16	0x00
Interface Timing 2 Register	ITMG2	0x17	0x4B
Interface Control 2 Register	ICTRL2	0x18	0x00
Horizontal Blank Register	HBLANK	0x19	0x00
Vertical Blank Register	VBLANK	0x1A	0x00
Configuration Register	CONFIG	0x1B	0x0C
Control Register	CONTROL	0x1C	0x04
Reserved		0x1D	—
Reserved		0x1E	—
Reserved		0x1F	—
Reserved		0x20	—

Setting Exposure and Gain

The exposure of an image is a function of the exposure and gain registers. Exposure sets the length of time each pixel integrates the light (shutter speed). Gain settings allow pixel values to be amplified. Gain values from 1x to 40x are allowed, but higher gain settings amplify noise (much like higher ISO film speeds are grainier). It is best to use the lower gain settings for better images. Gains from 1x to 10x are generally recommended.

There are three exposure registers (see Table 2).

The row exposure high register (upper 8 bits) and row exposure low register (lower 8 bits) act as a single 16 bit register. This 16 bit register sets the integration time (shutter speed) of the sensor. The sub-row exposure register is used for very small changes to exposure and allow fine-tuning for exact shutter speeds.

Table 2. Row Exposure Register Settings.

Register Name	Mnemonic	Address (hex)
Row Exposure Low Register	ROWEXPL	0x13
Row Exposure High Register	ROWEXPH	0x14
Sub-Row Exposure Register	SROWEXP	0x15

Proper exposure will result in black values near 0x00 and white values near 0xFF (assuming 8 bits). All six grey patches on the MacBeth chart should have different average intensity values in the image. If the two brightest patches both appear white then the exposure is too long. If the two darkest patches both appear black then the exposure is too short. Remember that the raw image does not have gamma correction applied yet. The final grey scale image needs to be evaluated after gamma correction.

Image Processing

The raw data from the sensor requires image processing before a digital image is ready for viewing. Some standard steps of image processing are as follows:

1. Defective pixel correction
2. Lens flare subtraction
3. Auto-exposure
4. Gamma correction
5. Data compression

Image processing is not part of the sensor and must be supplied separately. Image processors that are compatible with these sensors are available from Agilent Technologies and selected Agilent partners.

Typical Application

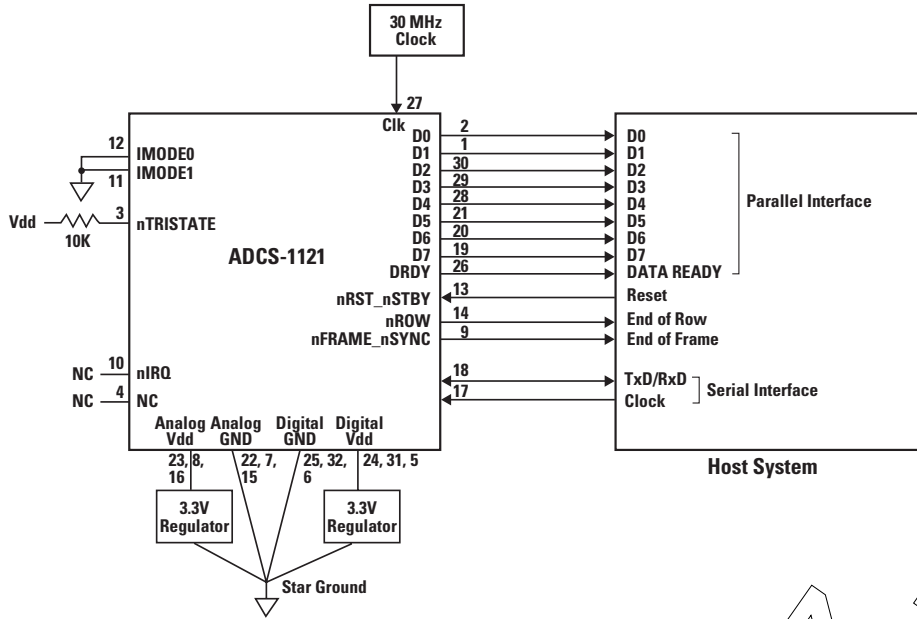

Typical Electrical Specifications

Part Number	ADCS-2121 (VGA)	ADCS-1121 (CIF)
Pixel size	7.4 x 7.4 μm	7.4 x 7.4 μm
Maximum Clock Rate	25 MHz (VGA)	32 MHz (CIF)
Effective Sensor Dynamic Range	65 dB (VGA)	61 dB (CIF)
Effective Noise Floor	43 e-	43 e-
Dark Signal ^[1,3]	240 e-/sec (@ 22°C)	240 e-/sec (@ 22°C)
Saturation Voltage	1.22 V	1.22 V
Full Well Capacity	68,000 e-	68,000 e-
Conversion Gain ^[2]	17 $\mu\text{V}/\text{e}$	17 $\mu\text{V}/\text{e}$
Programmable Gain Range	1 – 40 (8 bit resolution)	1 – 40 (8 bit resolution)
Fill Factor	42%	42%
Exposure Control	0.5 μsec minimum, 0.5 μsec increments	0.5 μsec minimum, 0.5 μsec increments
Supply Voltage	3.3 V, -5%/+10%	3.3 V, -5%/+10%
Absolute Max. Power Supply Voltage	3.6 V	3.6 V
Absolute Max. DC Input Voltage (any pin)	3.6 V	3.6 V
Power Consumption (typical)	150 mW operating, 150 μW standby	150 mW operating, 150 μW standby
Power Consumption (max)	200 mW operating, 3.3 mW standby	200 mW operating, 3.3 mW standby
Optical Format	1/3"	1/4"
Operating Temperature	-5° to +65°C	-5° to +65°C
Storage Temperature	-40° to +125°C	-40° to +125°C

Notes:

1. Specified over complete pixel area
2. Measured at unity gain
3. Excludes dark current shot noise

ADCS Sensor Top Level Block Diagram

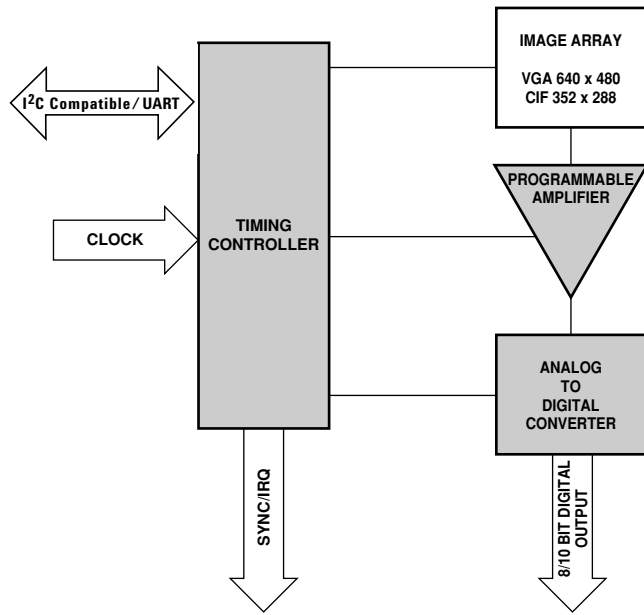

ADCS-2121 32 Pin Package Diagram

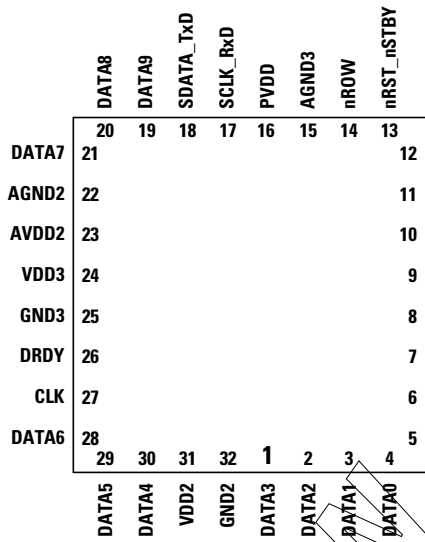

ADCS-1121 32 Pin Package Diagram

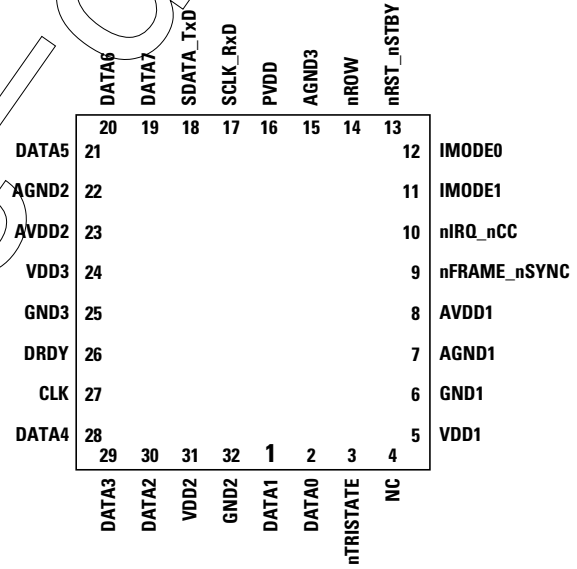

ADCS-2121 Pin Description

Pkg Pins	Signal Name	Type	Description
11	IMODE1	Input	If = 1, Half duplex UART slave interface mode If = 0, Synchronous serial slave interface mode
12	IMODE0	Input	Always = 0
27	CLK	Input	System Clock
13	nRST_nSTBY	Input	Active low system reset input and stand-by mode input
19, 20, 21, 28, 29, 30, 1, 2, 3, 4	Data 9, Data 8,... Data 1, Data 0	Output	Parallel digitized pixel data out
26	DRDY	Output	Data valid for parallel digitized pixel data out
18	SDATA_TxD	Input/output open drain	Serial output data
17	SCLK_RxD	Input	Transfer clock/serial data input
9	nFRAME_nSYNC	Output	Signals end of frame
14	nROW	Output	Signals end of row
10	nIRQ_nCC	Output	Programmable interrupt request
5, 31, 24	VDD	VDD	Digital power supply
6, 32, 25	GND	GND	Digital ground
16	PVDD	PVDD	Array power supply
8, 23	AVDD	AVDD	Analog power supply
7, 22, 15	AGND	AGND	Analog, array, and substrate ground

ADCS-1121 Pin Description

Pkg Pins (Location)	Signal Name	Type	Description
11	IMODE1	Input	If = 1, Half duplex UART slave interface mode If = 0, Synchronous serial slave interface mode
12	IMODE0	Input	Always = 0
27	CLK	Input	System Clock
13	nRST_nSTBY	Input	Active low system reset input and stand-by mode input
19, 20, 21, 28, 29, 30, 1, 2	Data 7, Data 6,... Data 1, Data 0	Output	Parallel digitized pixel data out
26	DRDY	Output	Data valid for parallel digitized pixel data out
18	SDATA_TxD	Input/output open drain	Serial output data
17	SCLK_RxD	Input	Transfer clock/serial data input
9	nFRAME_nSYNC	Output	Signals end of frame
14	nROW	Output	Signals end of row
10	nIRQ_nCC	Output	Programmable interrupt request
5, 31, 24	VDD	VDD	Digital power supply
6, 32, 25	GND	GND	Digital ground
16	PVDD	PVDD	Array power supply
8, 23	AVDD	AVDD	Analog power supply
7, 22, 15	AGND	AGND	Analog, array, and substrate ground
3	nTRISTATE	Input	Disables sensor tristate mode
4	NC	NC	No connect

Packaging

General Package Specs

- 32-pin CLCC (8 per side)
- Package dimensions, optical center shown in diagram below

Note:

This packaging complies with JEDEC Moisture Sensitivity Level 3.

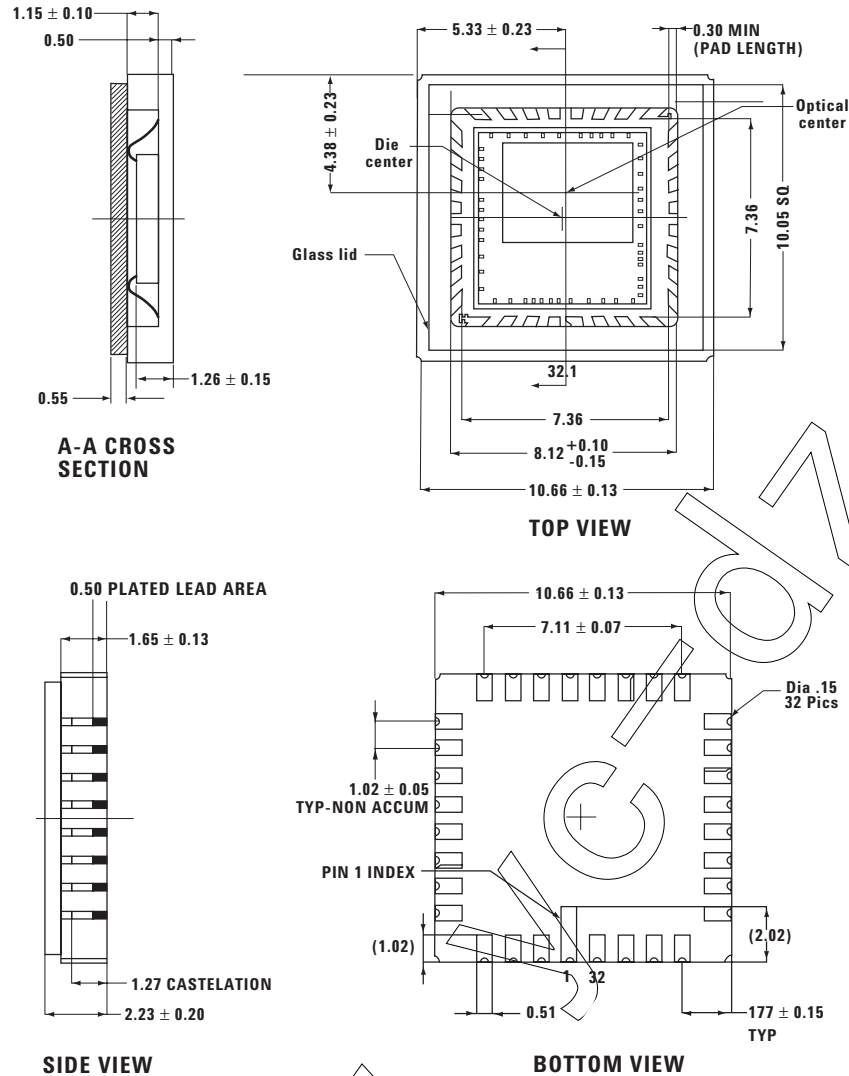

www.agilent.com/semiconductors

For product information and a complete list of distributors, please go to our web site.

For technical assistance call:

Americas/Canada: +1 (800) 235-0312 or (408) 654-8675

Europe: +49 (0) 6441 92466

China: 10800 650 0017

Hong Kong: (+65) 6271 2451

India, Australia, New Zealand: (+65) 6271 2394

Japan: (+81 3) 3335-8152 (Domestic/International), or 0120-61-1280 (Domestic Only)

Korea: (+65) 6271 2194

Malaysia, Singapore: (+65) 6271 2054

Taiwan: (+65) 6271 2654

Data subject to change.

Copyright © 2003 Agilent Technologies, Inc.

Obsoletes 55988-7291EN

January 14, 2003

5988-8615EN



Agilent Technologies