



**1550 nm Single-mode Transceiver (35dB margin)
 Small Form Pluggable (SFP), 3.3V
 155 Mbps SONET OC-3/SDH STM-1/125 Mbps Fast Ethernet**



Features

- Compliant with SONET/SDH standard
- Compliant with Fast Ethernet standard
- Industry standard small form pluggable (SFP) package
- Duplex LC connector
- Differential LVPECL inputs and outputs
- Single power supply 3.3V
- TTL signal detect indicator
- Hot Pluggable
- Class 1 laser product complies with EN 60825-1

Application

- Distributed multi-processing
- Switch to switch interface
- High speed I/O for file server
- Bus extension application
- Channel extender, data storage

Ordering Information

PART NUMBER	INPUT/OUTPUT	SIGNAL DETECT	VOLTAGE	TEMPERATURE
KS48-A3U-TI-N	AC/AC	TTL	3.3V	-40°C to 85°C

Absolute Maximum Ratings

PARAMETER	SYMBOL	MIN	MAX	UNITS	NOTE
Storage Temperature	T_S	-40	85	°C	
Supply Voltage	V_{CC}	-0.5	4.0	V	
Input Voltage	V_{IN}	-0.5	V_{CC}	V	
Output Current	I_o	---	50	mA	
Operating Current	I_{OP}	---	400	mA	



1550 nm Single-mode Transceiver (35dB margin)
Small Form Pluggable (SFP), 3.3V
155 Mbps SONET OC-3/SDH STM-1/125 Mbps Fast Ethernet

Recommended Operating Conditions

PARAMETER	SYMBOL	MIN	MAX	UNITS	NOTE
Case Operating Temperature	T_C	-40	85	°C	
Supply Voltage	V_{CC}	3.1	3.5	V	
Supply Current	$I_{TX} + I_{RX}$	---	250	mA	

Transmitter Electro-optical Characteristics

$V_{CC} = 3.1\text{ V to }3.5\text{ V}, T_C = -40\text{ °C to }85\text{ °C}$

PARAMETER	SYMBOL	MIN	TYP.	MAX	UNITS	NOTE
Data Rate	B	50	155	200	Mb/s	
Output Optical Power 9/125 μm fiber	P_{out}	0	---	+5	dBm	Average
Extinction Ratio	ER	10	---	---	dB	
Center Wavelength	λ_C	1530	1550	1570	nm	
Spectral Width (-20dB)	$\Delta\lambda$	---	---	1	nm	
Side Mode Suppression Ratio	$SMSR$	30	---	---	dB	
Rise/Fall Time (10–90%)	$T_{r,f}$	---	1	2	ns	
Output Eye	Compliant with Telcordia GR-253-CORE Issue 3 and ITU-T recommendation G-957					
Differential Input Voltage	V_{DIFF}	0.4	---	2.0	V	



**1550 nm Single-mode Transceiver (35dB margin)
Small Form Pluggable (SFP), 3.3V
155 Mbps SONET OC-3/SDH STM-1/125 Mbps Fast Ethernet**

Receiver Electro-optical Characteristics

$V_{CC} = 3.1\text{ V to }3.5\text{ V}, T_C = -40^\circ\text{C to }85^\circ\text{C}$

PARAMETER	SYMBOL	MIN	TYP.	MAX	UNITS	NOTE
Data Rate	B	50	155	200	Mb/s	
Optical Input Power -maximum	P_{IN}	0	---	---	dBm	Note 1
Optical Input Power -minimum (Sensitivity)	P_{IN}	---	---	-35	dBm	Note 1
Operating Center Wavelength	λ_C	1260	---	1600	nm	
Data Output Rise, Fall Time (10%~90%)	$T_{r,f}$	---	1	2	ns	
Loss of Signal-Asserted	P_A	---	---	-35	dBm	Average
Loss of Signal-Deasserted	P_D	-47	---	---	dBm	Average
Loss of Signal-Hysteresis	$P_A - P_D$	1.0	---	---	dB	
Differential Output Voltage	V_{DIFF}	0.5	---	1.8	V	
Receiver Loss of Signal Output Voltage-Low	RX_LOS_L	0	---	0.5	V	
Receiver Loss of Signal Output Voltage-High	RX_LOS_H	2.4	---	V_{CC}	V	

Note 1: The input data is at 155.52 Mbps, $2^{23}-1$ PRBS data pattern with 72 "1"s and 72 "0"s inserted per the ITU-T recommendation G.958 Appendix 1. The receiver is guaranteed to provide output data with Bit Error Rate (BER) better than or equal to 1×10^{-10} .



1550 nm Single-mode Transceiver (35dB margin)
Small Form Pluggable (SFP), 3.3V
155 Mbps SONET OC-3/SDH STM-1/125 Mbps Fast Ethernet

Block Diagram of Transceiver

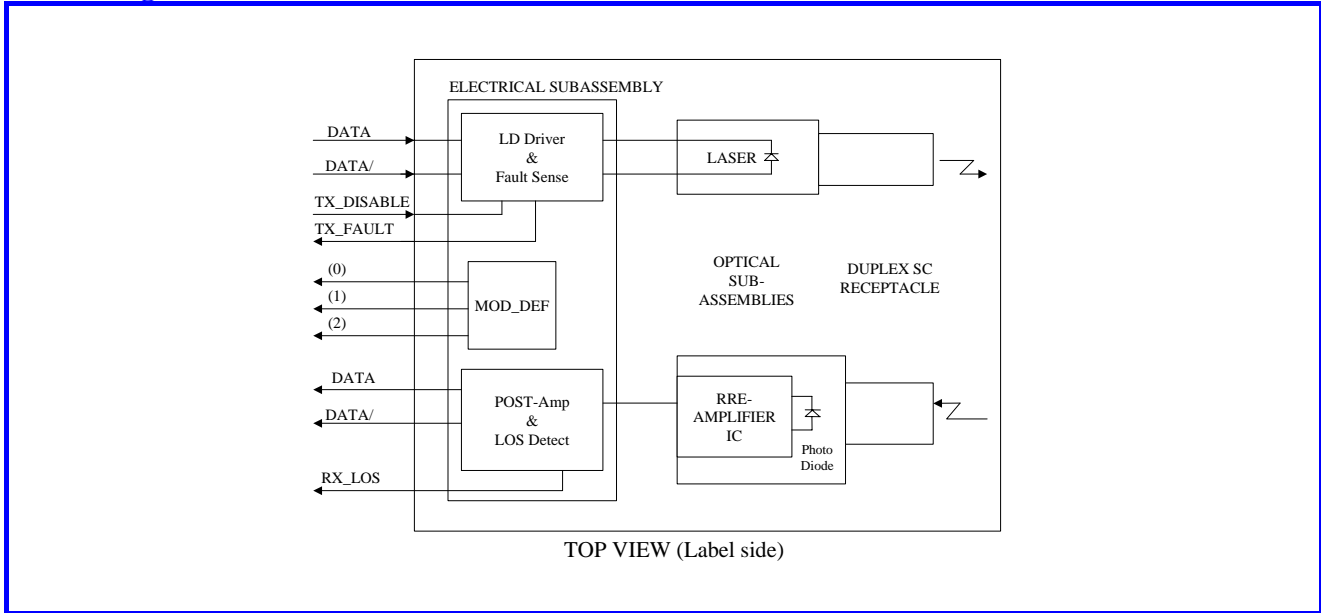

Transmitter Section

The transmitter section consists of a 1550 nm InGaAsP laser in an eye safe optical subassembly (OSA) which mates to the fiber cable. The laser OSA is driven by a LD driver IC which converts differential input LVPECL logic signals into an analog laser driving current.

TX_DISABLE

The TX_DISABLE signal is high (TTL logic "1") to turn off the laser output. The laser will turn on when TX_DISABLE is low (TTL logic "0").

Receiver Section

The receiver utilizes an InGaAs PIN photodiode mounted together with a trans-impedance preamplifier IC in an OSA. This OSA is connected to a circuit providing post-amplification quantization, and optical signal detection.

Receive Loss (RX_LOS)

The RX_LOS is high (logic "1") when there is no incoming light from the companion transceiver. This signal is normally used by the system for the diagnostic purpose. The signal is operated in TTL level.



1550 nm Single-mode Transceiver (35dB margin)
Small Form Pluggable (SFP), 3.3V
155 Mbps SONET OC-3/SDH STM-1/125 Mbps Fast Ethernet

Dimensions

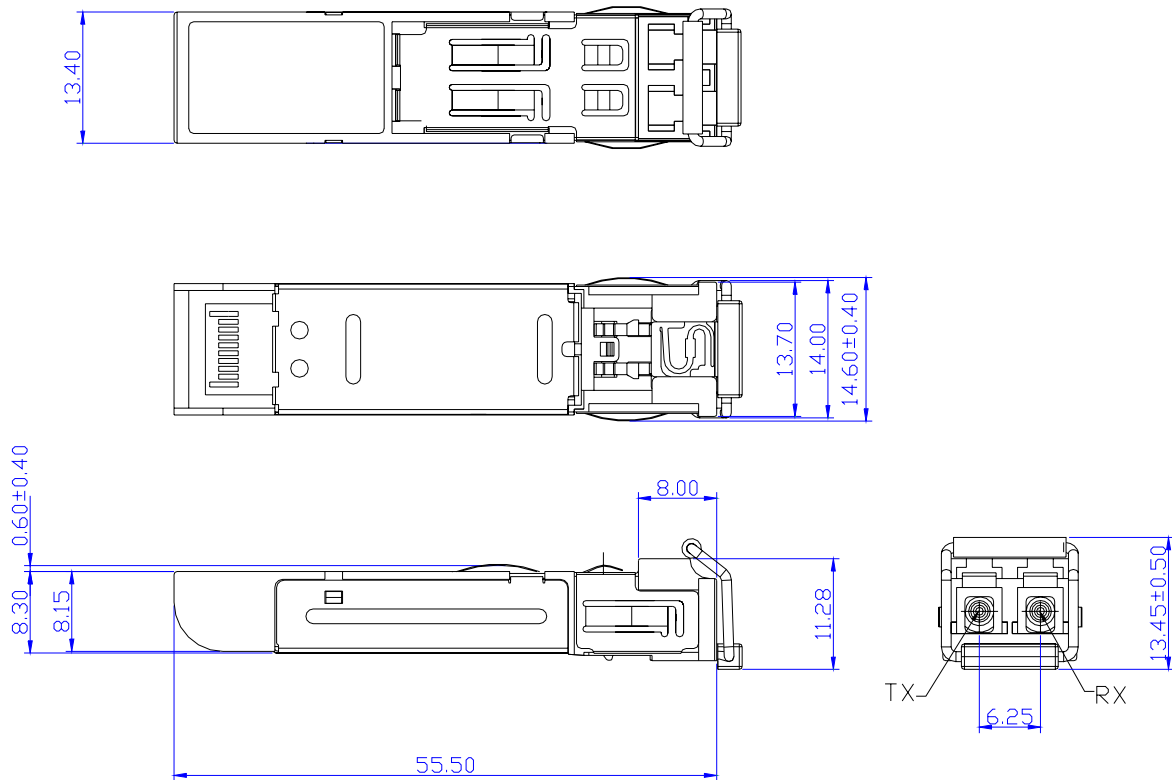

DIMENSIONS ARE IN MILLIMETERS

ALL DIMENSIONS ARE ± 0.2mm UNLESS OTHERWISE SPECIFIED

Unit: mm



1550 nm Single-mode Transceiver (35dB margin)
Small Form Pluggable (SFP), 3.3V
155 Mbps SONET OC-3/SDH STM-1/125 Mbps Fast Ethernet

Assembly drawing

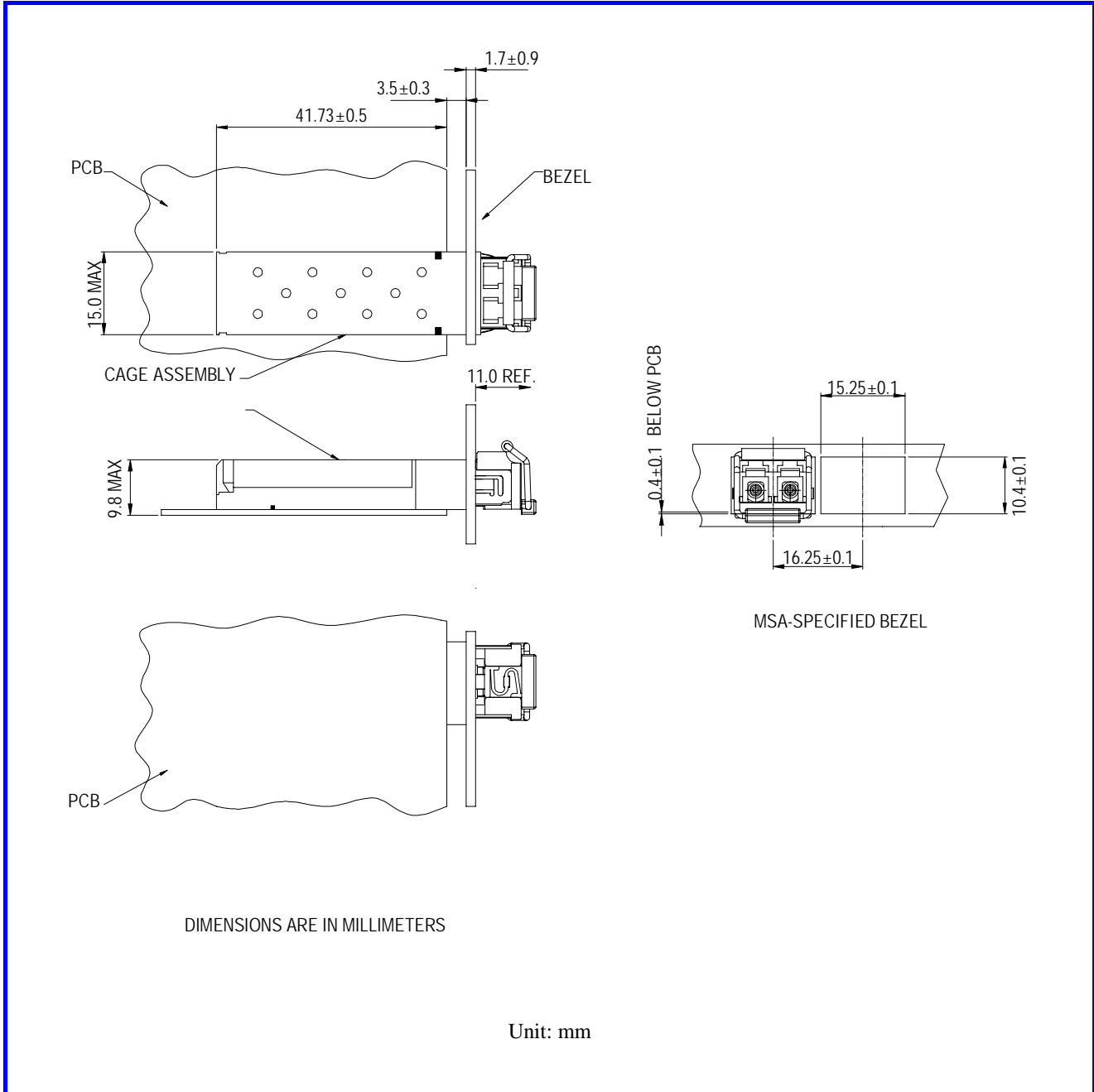



1550 nm Single-mode Transceiver (35dB margin)
Small Form Pluggable (SFP), 3.3V
155 Mbps SONET OC-3/SDH STM-1/125 Mbps Fast Ethernet

Pin Assignment

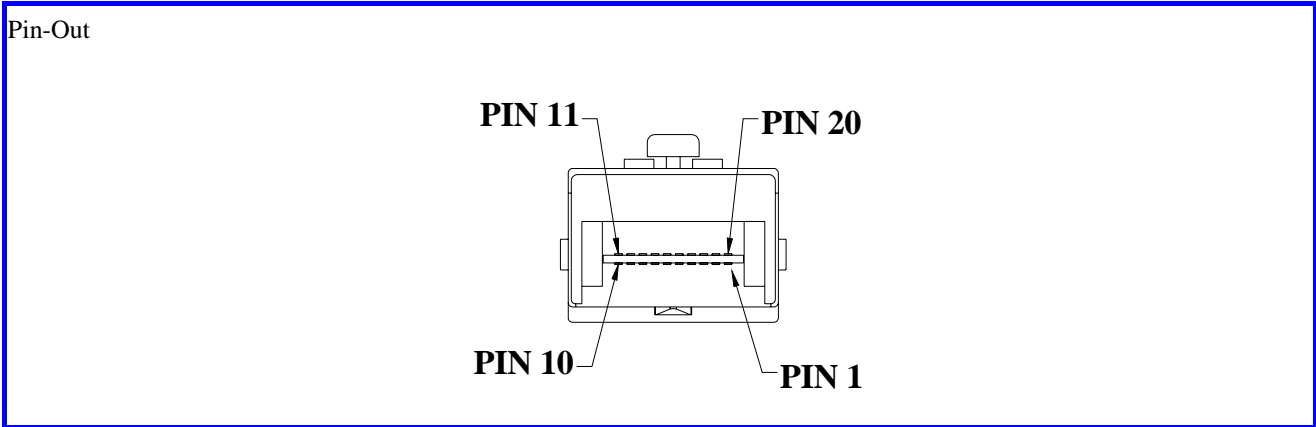

Pin	Signal Name	Description
1	T_{GND}	Transmit Ground
2	TX_FAULT	Transmit Fault
3	$TX_DISABLE$	Transmit Disable
4	$MOD_DEF (2)$	SDA Serial Data Signal
5	$MOD_DEF (1)$	SCL Serial Clock Signal
6	$MOD_DEF (0)$	TTL Low
7	$RATE_SELECT$	Open Circuit
8	RX_LOS	Receiver Loss of Signal, TTL High, open collector
9	R_{GND}	Receiver Ground
10	R_{GND}	Receiver Ground
11	R_{GND}	Receiver Ground
12	$RX-$	Receive Data Bar, Differential PECL, ac coupled
13	$RX+$	Receive Data, Differential PECL, ac coupled
14	R_{GND}	Receiver Ground
15	V_{CCR}	Receiver Power Supply
16	V_{CCT}	Transmitter Power Supply
17	T_{GND}	Transmitter Ground
18	$TX+$	Transmit Data, Differential PCEL, ac coupled
19	$TX-$	Transmit Data Bar, Differential PCEL, ac coupled
20	T_{GND}	Transmitter Ground



**1550 nm Single-mode Transceiver (35dB margin)
Small Form Pluggable (SFP), 3.3V
155 Mbps SONET OC-3/SDH STM-1/125 Mbps Fast Ethernet**

Eye Safety Mark

The KS4 series Single-mode transceiver is a class 1 laser product. It complies with EN 60825-1 and FDA 21 CFR 1040.10 and 1040.11. In order to meet laser safety requirements the transceiver shall be operated within the Absolute Maximum Ratings.

Caution

All adjustments have been done at the factory before the shipment of the devices. No maintenance and user serviceable part is required. Tampering with and modifying the performance of the device will result in voided product warranty.

Required Mark

Class 1 Laser Product
Complies with
21 CFR 1040.10 and 1040.11

Note : All information contained in this document is subject to change without notice.